

## 1. Structural Drawing

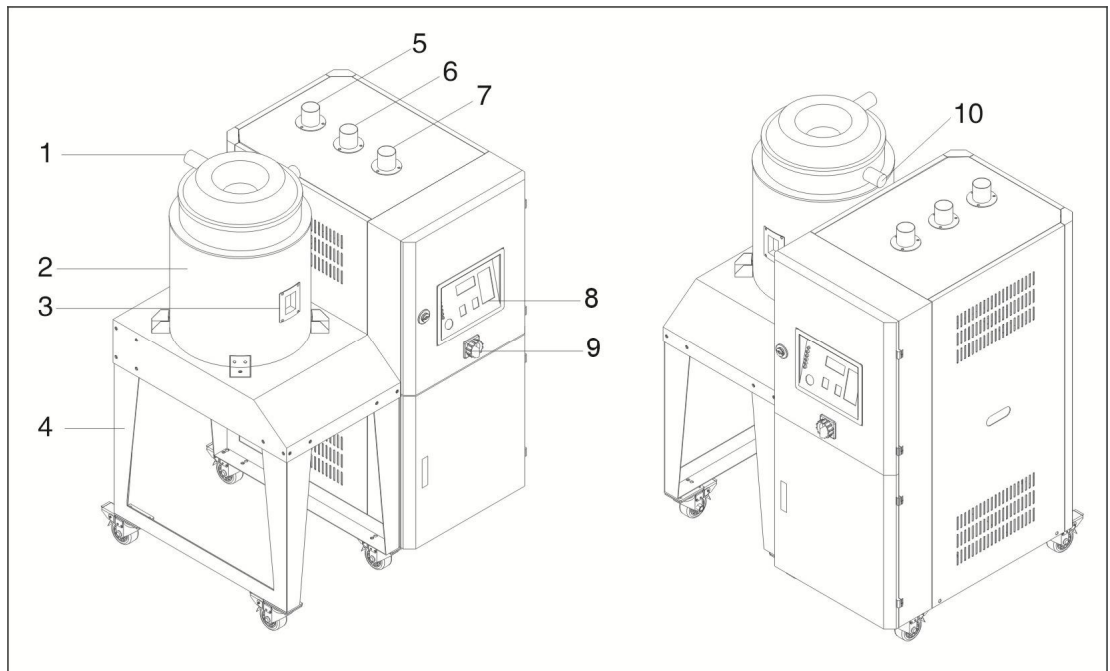

Parts name:

- |   |                            |                     |                    |
|---|----------------------------|---------------------|--------------------|
| 1. Return air outlet  | 2. Insulated drying hopper |                     |                    |
| 3. Sight-glass window (or maintainace door for hopper capacity more than 80U) |                            |                     |                    |
| 4. Floor stand  | 5. Dry air outlet          | 6. Return air inlet | 7. Moisture outlet |
| 8. Control panel  | 9. Main power switch       | 10. Dry air inlet   |                    |

## 2. Assembly Drawing (SDD-40U/40H~80U/40H)

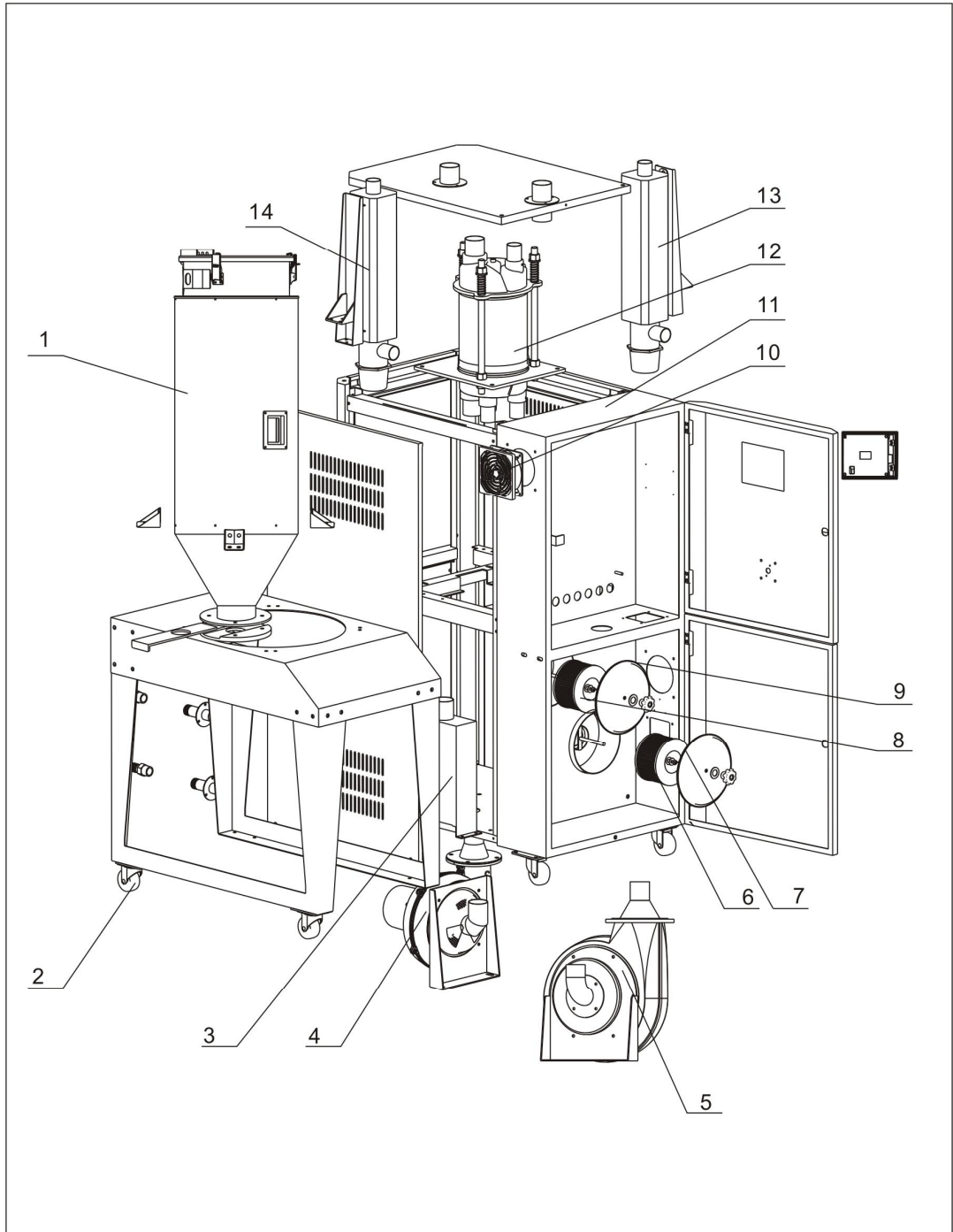

Remarks: Please refer to material list 3 for specific explanation of the Arabic numbers in parts drawing.

### 3. Parts List (SDD-40U/40H~80U/40H)

No.	Description	Part No.	
		40U/40H	80U/40H
1	Drying hopper		
2	Castor wheel	YW03000301100	YW03000301100
	Brake castor wheel	YW03000300000	YW03000300000
3	Cooler	BW88080000020	BW88080000020
4	Regen. blower *	BM40025300850	BM40025300850
5	Drying blower *	BM40000450850	BM40000450850
6	Drying filter **	YR50128300100	YR50128300100
7	Sealing for filtering barrel	YR10017000000	YR10017000000
8	Regen. filter **	YR50128300000	YR50128300000
9	Sealing for filtering barrel	YR10017000100	YR10017000100
10	Exhaust fan **	YM60121200400	YM60121200400
11	Rack metal plate	-	-
12	Honeycomb assembly	Refer to list 9	Refer to list 9
13	Regen. heater	Refer to list 11	Refer to list 11
14	Drying heater	Refer to list 11	Refer to list 11

\* means possible broken parts.

\*\* means easy broken part. and spare backup is suggested.

Please confirm the version of manual before placing the purchase order to guarantee that the item number of the spare part is in accordance with the real object.

#### 4. Assembly Drawing (SDD-120U/120H~230U/120H)

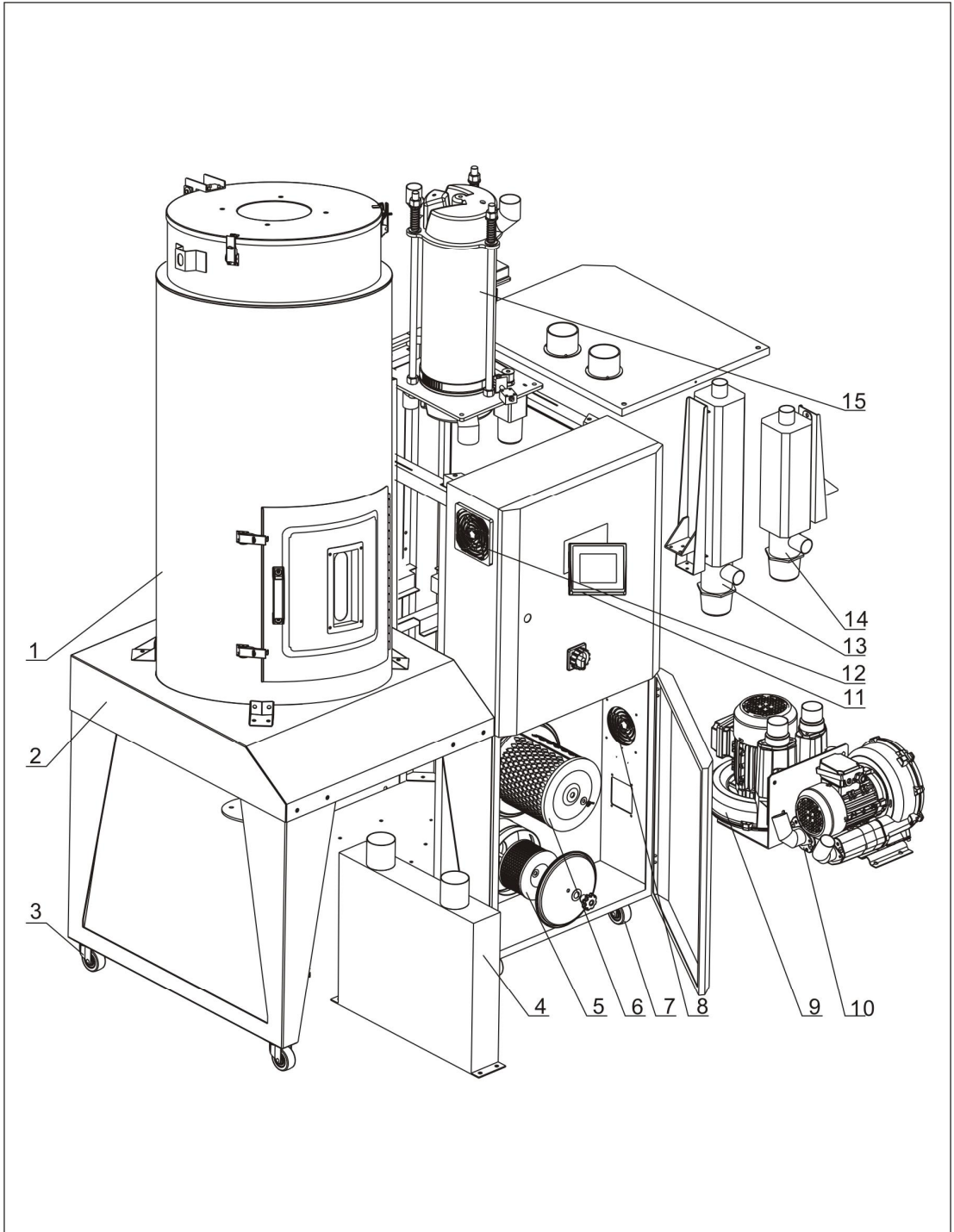

Remarks: Please refer to material list 5 for specific explanation of the Arabic numbers in parts drawing.

## 5. Parts List (SDD-120U/120H~230U/120H)

No.	Description	Part No.		
		120U/120H	160U/120H	230U/120H
1	Drying hopper	-	-	-
2	Rack metal plate	-	-	-
3	Brake castor wheel	YW03000300000	YW03000300000	YW03000300000
4	Cooler	BW88080000020	BW88080000020	BW88080000020
5	Regen. filter **	YR50128300000	YR50128300000	YR50128300000
6	Drying filter **	YR50708000200	YR50708000200	YR50708000200
7	Castor	YW03000300200	YW03000300200	YW03000300200
8	Anti-dust screen	YR40120300000	YR40120300000	YR40120300000
9	Drying blower *	BM30031000150	BM30031000150	BM30031000150
10	Regen. blower *	BM30020500050	BM30020500050	BM30020500050
11	Control panel	YE80878500100	YE80878500100	YE80878500100
12	Exhaust fan **	YM60121200400	YM60121200400	YM60121200400
13	Drying heater	Refer to list 11	Refer to list 11	Refer to list 11
14	Regen. heater	Refer to list 11	Refer to list 11	Refer to list 11
15	Honeycomb assembly	Refer to list 9	Refer to list 9	Refer to list 9

\* means possible broken parts.

\*\* means easy broken part. and spare backup is suggested.

Please confirm the version of manual before placing the purchase order to guarantee that the item number of the spare part is in accordance with the real object.

## 6. Assembly Drawing (SDD-300U/200H~1200U/700H)

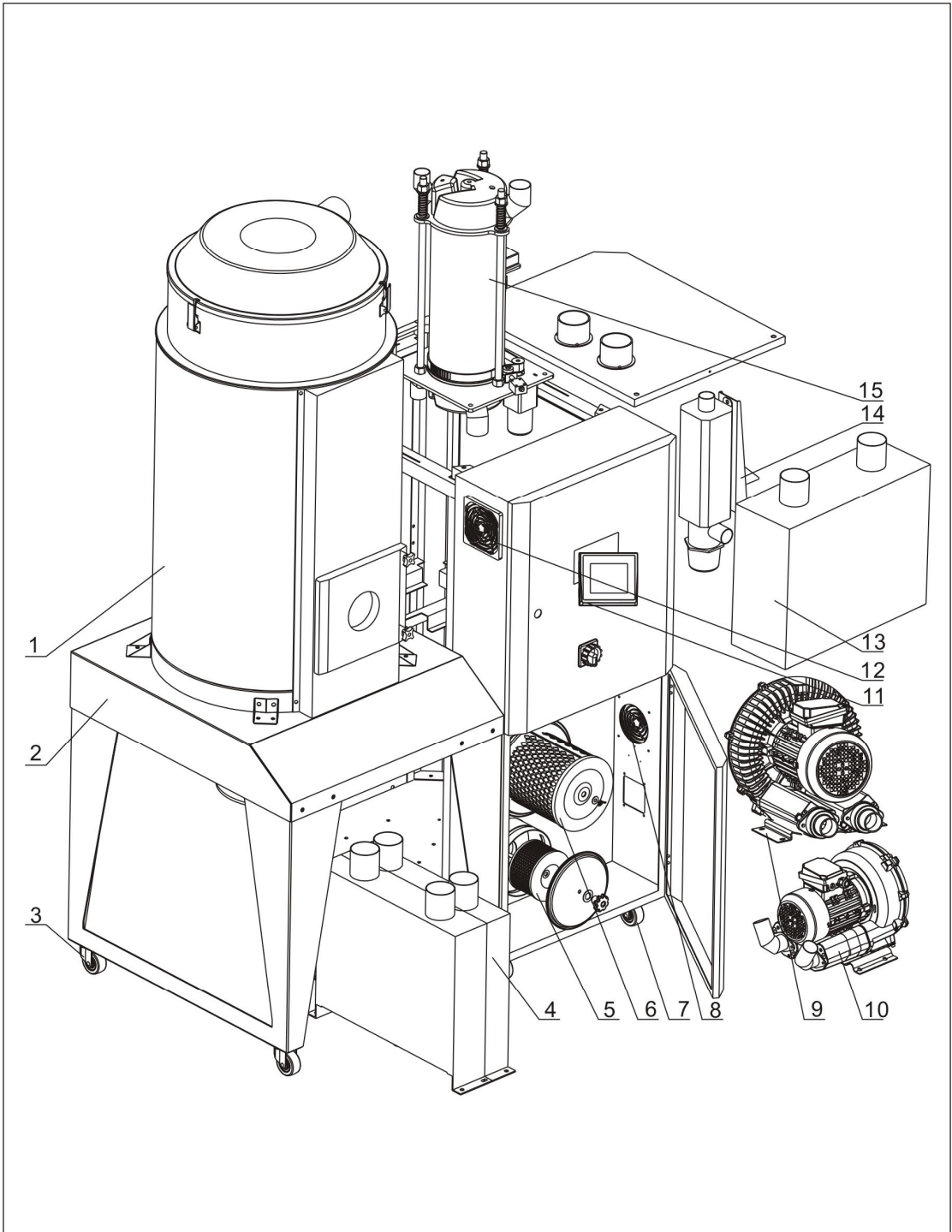

Remarks: Please refer to material list 7 for specific explanation of the Arabic numbers in parts drawing.

## 7. Parts List (SDD-300U/200H~1200U/700H)

No.	Description	Part No.			
		300U/200H	450U/200H	600U/400H	750U/400H
1	Drying hopper	BK0430000020	BK0445000020	BY10060000250	BY10075000050
2	Rack metal plate	BK04030000720	BK04045000920	BK04060001120	BK04075001320
3	Brake castor wheel	YW03000300000	YW03000300000	YW03000300000	YW03000300000
4	Cooler	BL03154040120	BL03154040120	BW88030300020	BW88030300020
		BW88152000020	BW88152000020	BW88030030020	BW88030030020
5	Regen. filter **	YR50708000100	YR50708000100	YR50708000100	YR50708000100
6	Drying filter **	YR50203000100	YR50203000100	YR50241400000	YR50241400000
7	Castor wheel	YW03000300200	YW03000300200	YW03000400200	YW03000300200
8	Anti-dust screen	YR40120300000	YR40120300000	YR40120300000	YR40120300000
9	Drying blower *	BM30042000050	BM30042000050	BM30055000050	BM30055000050
10	Regen. blower *	BM30020500050	BM30020500050	BM30031000150	BM30031000150
11	Control panel	YR40000400500	YR40000400500	YR40000400500	YR40000400500
12	Exhaust fan **	YM60121200400	YM60121200400	YM60121200400	YM60121200400
13	Heater case	Refer to list 11	Refer to list 11	Refer to list 11	Refer to list 11
14	Regen. heater	Refer to list 11	Refer to list 11	Refer to list 11	Refer to list 11
15	Honeycomb assembly	Refer to list 9	Refer to list 9	Refer to list 9	Refer to list 9

No.	Description	Part No.	
		900U/700H	1200U/700H
1	Drying hopper	BY10090000550	BY10120000150
2	Rack metal plate	BK04907000020	BK04120000520
3	Brake castor wheel	YW03000300000	YW03000300000
4	Cooler	BL03507045020	BL03507045020
		BW88507000020	BW88507000020
5	Regen. filter **	YR50203000000	YR50203000000
6	Drying filter **	YR50241400000	YR50241400000
7	Castor wheel	YW03000300200	YW03000300200
8	Anti-dust screen	YR40120300000	YR40120300000
9	Drying blower *	BM30075000050	BM30075000050
10	Regen. blower *	BM30042000050	BM30042000050
11	Control panel	YR40000400500	YR40000400500
12	Exhaust fan **	YM60121200400	YM60121200400
13	Heater case	Refer to list 11	Refer to list 11
14	Regen. heater	Refer to list 11	Refer to list 11
15	Honeycomb assembly	Refer to list 9	Refer to list 9

\* means possible broken parts.

\*\* means easy broken part. and spare backup is suggested.

Please confirm the version of manual before placing the purchase order to guarantee that the item number of the spare part is in accordance with the real object.

## 8. Honeycomb Assembly

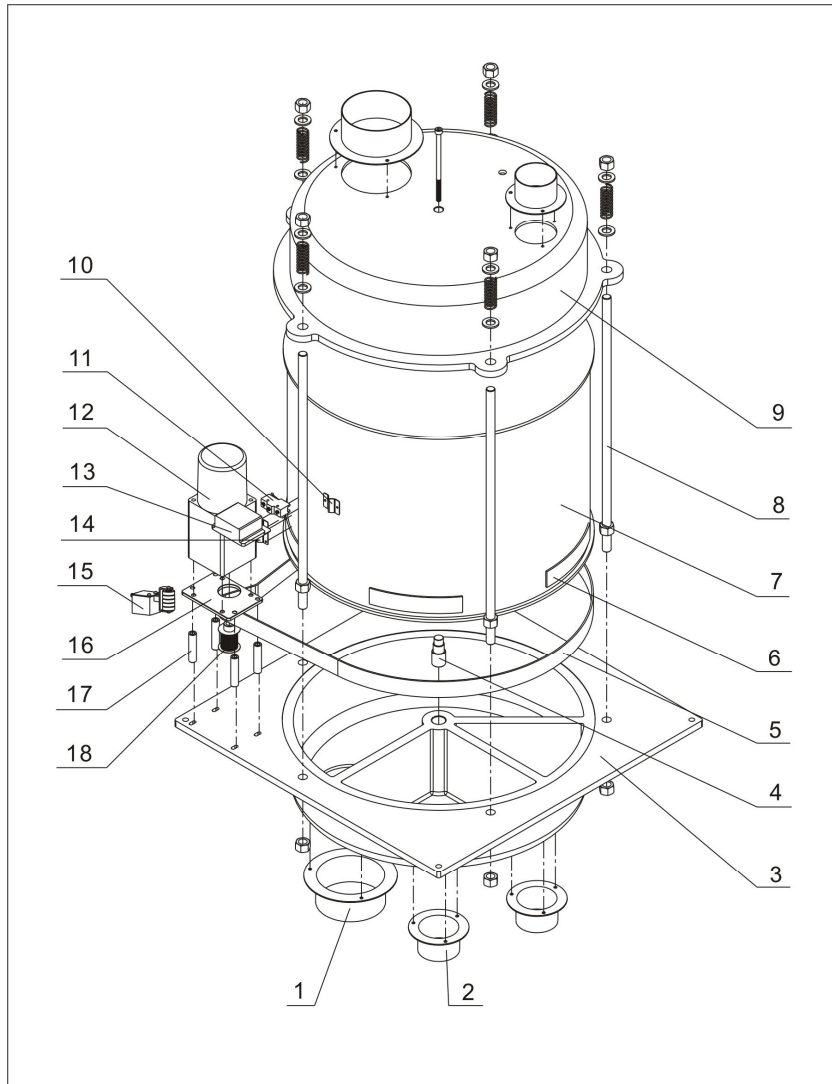

Remarks: Please refer to material list 9 for specific explanation of the Arabic numbers in parts drawing.



## 9. Parts List of Honeycomb Assembly

No.	Description	Part No.		
		40U/40H~80U/40H	120U/120H~230U/120H	300U/200H~450U/200H
1	Honeycomb flange	-	-	-
2	Honeycomb flange	-	-	-
3	Honeycomb lower cover	-	-	-
4	Honeycomb installation shaft	-	-	-
5	Synchronous belt **	YR00025400000	YR00203000000	YR00203400000
6	Synchronous belt	-	-	-
7	Honeycomb	YM71018000500	YW71022000000	YW71025000700
8	Double-head screw	BH10533000010	BH10533000010	BH11100000210
9	Honeycomb upper cover	-	-	-
10	Honeycomb fixing plate	-	-	-
11	Position limit switch*	YE14511200000	YE14511200000	YE14511200000
12	Gear motor	YM50031500000	YM50512600000	YM50512600000
13	Microswitch box	-	-	-
14	Belt tension regulator	-	-	-
15	Mounting plate of gear motor	-	-	-
16	Fixing pipe	-	-	-
17	Synchronous wheel	-	-	-
No.	Description	Part No.		
		600U/400H~750U/400H	900U/700H~1200U/700H	
1	Honeycomb flange	-	-	
2	Honeycomb flange	-	-	
3	Honeycomb lower cover	-	-	
4	Honeycomb installation shaft	-	-	
5	Synchronous belt **	YR00304700000	YR00305800000	
6	Synchronous belt	-	-	
7	Honeycomb	YW71035000700	YW71044000700	
8	Double-head screw	BH11100000210	BH11100000210	
9	Honeycomb upper cover	-	-	
10	Honeycomb fixing plate	-	-	
11	Position limit switch*	YE14511200000	YE14511200000	
12	Gear motor	YM50512600000	YM50512600000	
13	Microswitch box	-	-	
14	Belt tension regulator	-	-	
15	Mounting plate of gear motor	-	-	
16	Fixing pipe	-	-	
17	Synchronous wheel	-	-	

\* means possible broken parts.

\*\* means easy broken part. and spare backup is suggested.

Please confirm the version of manual before placing the purchase order to guarantee that the item number of the spare part is in accordance with the real object.

## 10. Heater Assembly

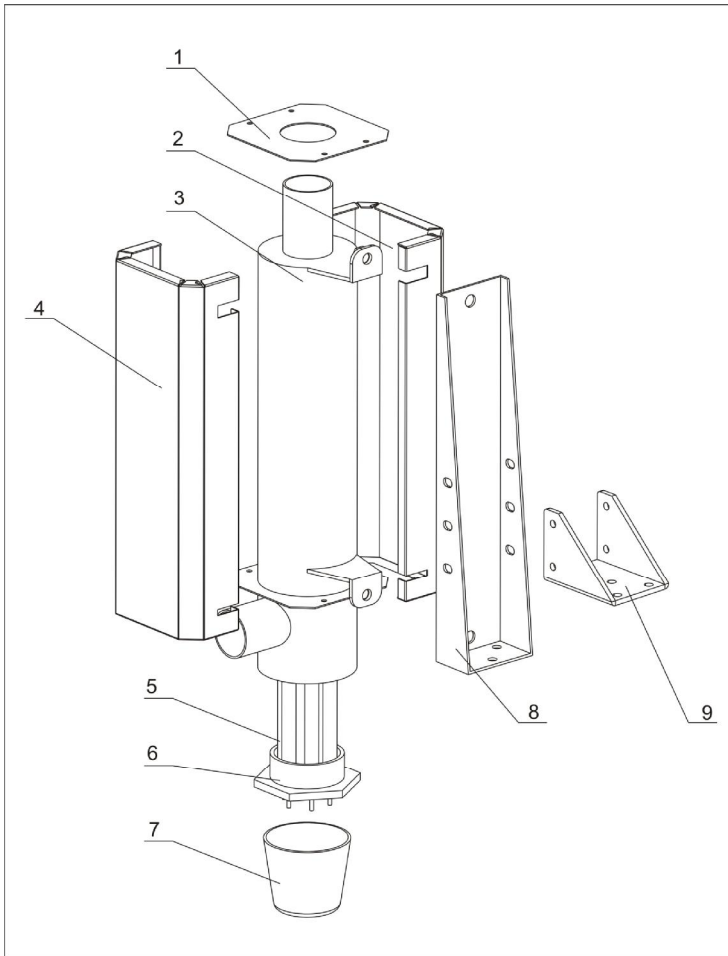

Remarks: Please refer to material list 11 for specific explanation of the Arabic numbers in parts drawing.

## 11. Part List of Heater Assembly

SDD-40U/40H-80U/40H					
No.	Description	Part No.	No.	Description	Part No.
1	Heater cover plate	-	6	Heater copper head	BH12200500310
2	Heater cover plate 1	-	7	Bakelite cover	YR40002000100
3	Heating tank	-	8	Heater fixed frame	-
4	Heater cover plate 2	-	9	Heater fixed corner	-
5	Drying pipe heater *	BH70150400050			
	Regenerating pipe heater *	BH70183460000			
SDD-120U/120H-230U/120H					
No.	Description	Part No.	No.	Description	Part No.
1	Heater cover plate	-	6	Heater copper head	BH12200500310
2	Heater cover plate 1	-	7	Bakelite cover	YR40002000100
3	Heating tank	-	8	Heater fixed frame	-

4	Heater cover plate 2	-	9	Heater fixed corner	-
5	Drying pipe heater *	BH70120600050			
	Regenerating pipe heater *(50Hz)	BH70183460000			
	Regenerating pipe heater *(60Hz)	BH70150400050			
<b>SDD-300U/200H-450U/200H</b>					
No.	Description	Part No.	No.	Description	Part No.
1	Heater cover plate	-	6	Heater copper head	BH12200500310
2	Heater cover plate 1	-	7	Bakelite cover	YR40002000100
3	Heating tank	-	8	Heater fixed frame	-
4	Heater cover plate 2	-	9	Heater fixed corner	-
5	Pipe heater *(50Hz)	BH70150400050			
	Pipe heater *(60Hz)	BH70120600050			
<b>SDD-600U/400H-750U/400H</b>					
No.	Description	Part No.	No.	Description	Part No.
1	Heater cover plate	-	6	Heater copper head	BH12200500310
2	Heater cover plate 1	-	7	Bakelite cover	YR40002000100
3	Heating tank	-	8	Heater fixed frame	-
4	Heater cover plate 2	-	9	Heater fixed corner	-
5	Pipe heater *	BH70407200050			
<b>SDD-900U/700H-1200U/700H</b>					
No.	Description	Part No.	No.	Description	Part No.
1	Heater cover plate	-	6	Heater copper head	BH12200500310
2	Heater cover plate 1	-	7	Bakelite cover	YR40002000100
3	Heating tank	-	8	Heater fixed frame	-
4	Heater cover plate 2	-	9	Heater fixed corner	-
5	Pipe heater *	BH70501000050			

\* means possible broken parts.

\*\* means easy broken part. and spare backup is suggested.

Please confirm the version of manual before placing the purchase order to guarantee that the item number of the spare part is in accordance with the real object.

## 12. Heater Case Assembly(SDD-300U/200H~1200U/700H)

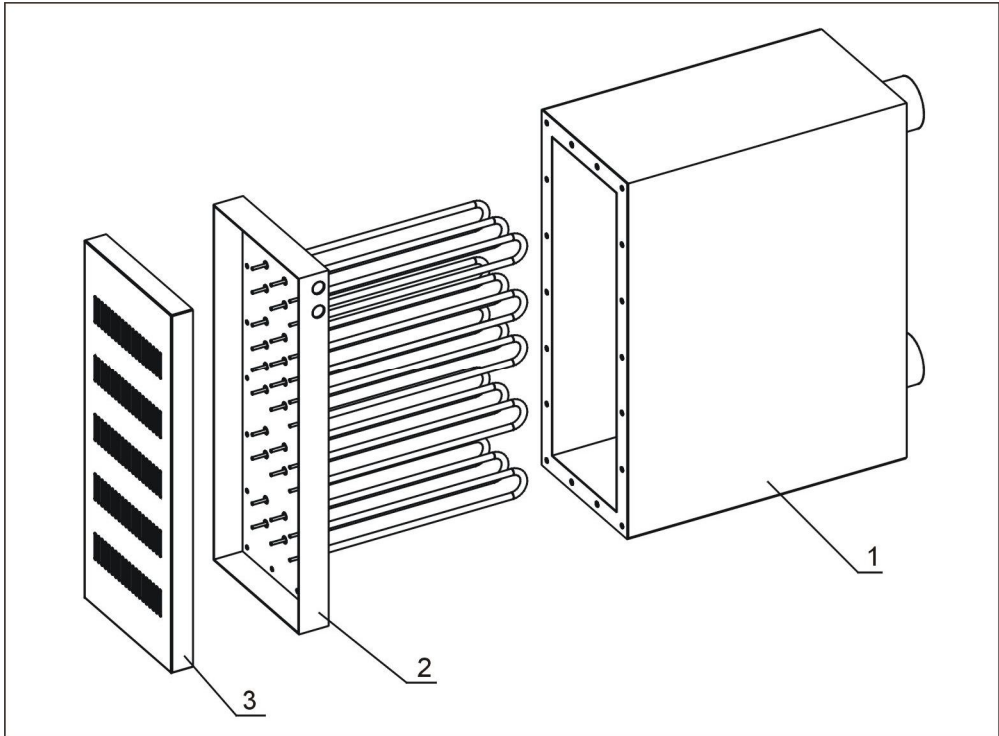

Remarks: Please refer to material list 13 for specific explanation of the Arabic numbers in parts drawing.

## 13. Part List of Process Heater Case Ass. (SDD-300U/200H~1200U/700H)

No.	Description	Part No.		
		300U/200H ~450U/200H	600U/400H ~750U/400H	900U/700H ~1200U/700H
1	Heater case	-	-	-
2	Pipe heater*	BH70124000550	BH70184000550	BH70244000850
3	Heater case cover plate	-	-	-

\* means possible broken parts.

\*\* means easy broken part. and spare backup is suggested.

Please confirm the version of manual before placing the purchase order to guarantee that the item number of the spare part is in accordance with the real object.