

SG-14 Series

Screenless Granulators

Date: Apr, 2013

Version: Ver.B (English)



Contents

1. General Description	9
1.1 Coding Principle	10
1.2 Feature	10
1.3 Technical Specifications	12
1.3.1 Technical Specifications	12
1.3.2 Dimensions	13
1.4 Safety Regulations	14
1.4.1 Safety Signs and Labels	14
1.4.2 Transportation and Storage of the Machine	16
1.4.3 Working Environment	16
1.4.4 Rejected Parts Disposal	17
1.5 Exemption Clause	17
2. Structural Features and Working Principle	18
2.1 General Description	18
2.1.1 Working Principle	18
2.1.2 Safety System	19
2.2 Assembly Drawing	21
2.2.1 Assembly Drawing	21
2.2.2 Parts list	22
2.2.3 Cutting Chamber	24
2.2.4 Cutting Chamber Parts List	24
2.2.5 Blade Rest	25
2.2.6 Blade Rest Parts List	25
2.2.7 Transmission Parts	26
2.2.8 Transmission Parts List	26
2.2.9 Feed Box, Feed Port and Material Stopper	27
2.2.10 Feed Box, Feed Port and Material Stopper Parts List	27
2.2.11 Storage Box	28
2.2.12 Storage Box Parts List	28
2.2.13 Main Body	29
2.2.14 Main Body Parts List	29

2.3	Electrical Diagram	30
2.3.1	Main Circuit (400V).....	30
2.3.2	Control Circuit (400V)	31
2.3.3	Components Layout (400V).....	33
2.3.4	Electrical Components List (400V).....	34
2.3.5	Main Electrical Circuit (230V)	35
2.3.6	Control Circuit (230V)	36
2.3.7	Components Layout (230V).....	38
2.3.8	Electrical Components List (230V).....	39
2.4	Electrical Components Description	40
3.	Installation and Debugging.....	41
3.1	Installation Notice:.....	42
3.2	Installation Place	43
3.3	Installation of Bearing and Blade Rest	43
3.4	Installation of Gear Motor and Coupling	44
3.5	Installation of Rotating Blade and Fixed Blade.....	45
3.6	Installation of Feed Box, Feed Port and Storage Box	46
4.	Operation Guide	48
4.1	Startup Pretest	48
4.1.1	Before the First Startup.....	48
4.1.2	After Startup for 2 Hours.....	48
4.2	Circuit Connection.....	48
4.2.1	Check the Running Direction of the Motor	49
4.3	Open the Feed Box and Storage Box	49
4.3.1	Open the Feed Box.....	49
4.3.2	Open the Storage Box	49
4.4	Shut the Feed Box and Storage Box.....	50
4.4.1	Shut the Feed Box.....	50
4.4.2	Shut the Storage Box.....	50
4.5	Start and Stop the Granulator	50
4.6	Motor Reversed Protective Function	52
5.	Trouble-shooting	53
5.1	Granulator Can Not Work.....	53

5.2 Stop Due to Other Reasons	53
6. Maintenance and Repair	55
6.1 Repair	55
6.1.1 Replace the Blades.....	55
6.2 Maintenance	57
6.2.1 Daily Check	57
6.2.2 Weekly Check.....	58
6.2.3 Monthly Check.....	58
6.2.4 Check and Maintenance of Gear Motor	58
6.3 Cleaning.....	59
6.4 Maintenance Schedule.....	61
6.4.1 About the Machine.....	61
6.4.2 Check After Installation.....	61
6.4.3 Daily Check	61
6.4.4 Weekly Check.....	61
6.4.5 Monthly Check.....	61
6.4.6 Check Half-yearly or Every 1000 Running Hours	62
6.4.7 3 year Checking.....	62

Table index

Table 1-1: Technical Specifications.....	12
Table 2-1: Parts List	22
Table 2-2: Parts List	24
Table 2-3: Blade Rest Parts List	25
Table 2-4: Transmission Parts List.....	26
Table 2-5: Feed Box, Feed Port and Material Stopper Parts List.....	27
Table 2-6: Storage Box Parts List	28
Table 2-7: Main Body Parts List	29
Table 2-8: Electrical Components List (SG-1411/1417) (400V)	34
Table 2-9: Electrical Components List (SG-1411/1417) (230V)	39

Picture index

Picture 1-1: Dimensions	13
Picture 2-1: Working Principle	18
Picture 2-2: Safety System	19
Picture 2-3: Emergency Stop Switch	20
Picture 2-4: Safety System	20
Picture 2-5: Assembly Drawing	21
Picture 2-6: Cutting Chamber	24
Picture 2-7: Blade Rest	25
Picture 2-8: Transmission Parts	26
Picture 2-9: Feed Box, Feed Port and Material Stopper	27
Picture 2-10: Storage Box	28
Picture 2-11: Main Body	29
Picture 2-12: Main Circuit (400V)	30
Picture 2-13: Control Circuit 1(400V)	31
Picture 2-14: Control Circuit 2(400V)	32
Picture 2-15: Components Layout (400V)	33
Picture 2-16: Main Electrical Circuit (230V)	35
Picture 2-17: Control Circuit 1(230V)	36
Picture 2-18: Control Circuit 2(230V)	37
Picture 2-19: Components Layout (230V)	38
Picture 2-20: Electrical Components Description	40
Picture 3-1: Installation Space	42
Picture 3-2: Installation Place	43
Picture 3-3: Installation of Bearing and Blade Rest 1	43
Picture 3-4: Installation of Bearing and Blade Rest 2	44
Picture 3-5: Installation of Bearing and Blade Rest 1 3	44
Picture 3-6: Installation of Gear Motor and Coupling	44
Picture 3-7: Installation of Rotating Blade and Fixed Blade 1	45
Picture 3-8: Installation of Rotating Blade and Fixed Blade 2	45
Picture 3-9: Installation of Rotating Blade and Fixed Blade 3	46
Picture 3-10: Installation of Feed Box, Feed Port and Storage Box 1	46
Picture 3-11: Installation of Feed Box, Feed Port and Storage Box 2	47
Picture 3-12: Installation of Feed Box, Feed Port and Storage Box 3	47
Picture 4-1: Open the Feed Box	49

Picture 4-2: Open the Storage Box	50
Picture 4-3: Main Power Switch	51
Picture 4-4: START, Emergency Button and STOP Button.....	51
Picture 4-5: Motor Reversed Protective Function.....	52
Picture 6-1: Replace the Blades.....	56
Picture 6-2: Star Screw	58
Picture 6-3: Cleaning.....	60

1. General Description



Please read this manual carefully before using this machine in order to operate correctly against any damage caused due to improper operation.



Note!

Always take great care when the knives are within reach, they are very sharp and can cause personal injury.



Forbidden to process flammable or toxic material!

SG-14 series granulators operate in super low speed to cut materials into well-proportioned granules. There are least dusts produced in the cutting process. Multiple security devices ensure high safety grade; automatic reverse running function ensures continuous operation. This series of screenless granulators are suitable for granulating hard and thick materials. For SG-24T series, there are two gear motors and two cutting chambers to work simultaneously. It can granulate the sprues and waste material, also is capable of granulating long and thin or tough sprues.



Model: SG-1417

1.1 Coding Principle

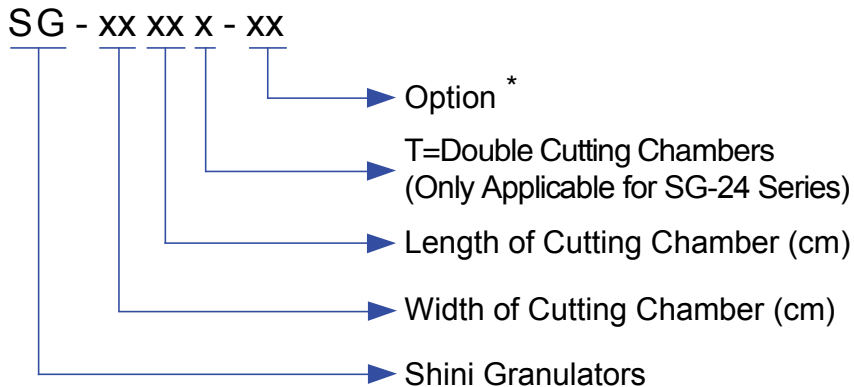

Note: *

VR=Loading by High Pressure Air BR=Loading by Bolwer
BC=Blower Conveying & Cyclone Dust Collector
DS=Dust Separator H=Higher Motor Power
R=For Stainless Steel Made Feed Port and Storage Tank
CE=CE Conformity

1.2 Feature

Standard configuration

- 1) SG-14 series German-made gear motor features steady performance, long service life and high torque.
- 2) SG-14 series teeth cutters and cutting blades are integrally fitted in one cutting chamber.
- 3) New-type inclined teeth cutter reduces the possibility of stress concentration, enhance bearing capacity and converts force direction so that cutter lifespan can be prolonged.
- 4) SG-14 series motor shaft and rotor shaft are connected by shaft coupling thus ensuring smooth cutting action and convenient motor replacement.
- 5) When motor blockage occurs, the machine will alarm visibly and enable motor fo run reversely. It resumes normal operation automatically after the trouble is clear.
- 6) European type appearance, compact in size and easy to access for cleaning and maintenance.
- 7) Transparent PC feeding hopper.

8) Screenless design, well-proportioned size of regrinds and least amount of dusts. Regrinds could be used with virgin materials.

Accessory option

1) 30-second instant recycling system, regrind conveying via blower & cyclone, dust separator, manual storage bin and full-receiver alarm device.

All service work should be carried out by a person with technical training or corresponding professional experience. The manual contains instructions for both handling and servicing. Chapter 6, which contains service instructions intended for service engineers. Other chapters contain instructions for the daily operator.

Any modifications of the machine must be approved by SHINI in order to avoid personal injury and damage to machine. We shall not be liable for any damage caused by unauthorized change of the machine.

Our company provides excellent after-sales service. Should you have any problem during using the machine, please contact the company or the local vendor.

Headquarter and Taipei factory:

Tel: (886) 2 2680 9119

Shini Plastics Technologies (Dongguan), Inc:

Tel: (86) 769 8111 6600

Shini Plastics Technologies India Pvt.Ltd.:

Tel: (91) 250 3021 166

1.3 Technical Specifications

1.3.1 Technical Specifications

Table 1-1: Technical Specifications

Model	SG-1411	SG-1417
Motor Power (kW, 50/60Hz)	0.37 / 0.45	0.37 / 0.45
Rotating Speed (r.p.m, 50/60Hz)	26 / 32	26 / 32
Material of Teeth Cutters	SKD-11	SKD-11
Number of Cutting Blades	1	2
Number of Teeth Cutters	2	3
Number of Large Teeth Cutlers	/	/
Number of Small Teeth Cutlers	/	/
Cutting Chamber (mm)	140×110	140×175
Max. Throughput Capacity (kg/hr, 50/60Hz)	2 / 3	3 / 4
Noise Level dB(A)	60~68	60~68
30-Sec. Instant Recycling	/	/
Regrind Conveyor (BC Type)	/	/
Dust Separator	/	/
Level Detector	/	/
Proportional Valve	/	/
Manual Storage Bin	/	/
Dimensions		
H (mm)	1160	1360
H1 (mm)	/	/
W (mm)	290	290
W1 (mm)	235	235
D (mm)	740	785
D1 (mm)	210	266
Weight (kg)	83	92

Note: 1) For stainless steel made feed port and manual storage bin, plus "R" at model behind.

2) Max. Capacity of the machine is subject to the size and composition of the material.

3) Noise level will vary with different materials.

4) SKD11 is material code number of Japanese JIS standard.

5) Teeth cutter blades with 3mm width as standard, 4mm as optional (SG - 14).

6) For avoiding plastic to adhibit the blade, all materials should be crushed at normal temperature.

7) Power supply: 3Φ, 230 / 400 / 460 / 575VAC, 50 / 60Hz.

1.3.2 Dimensions

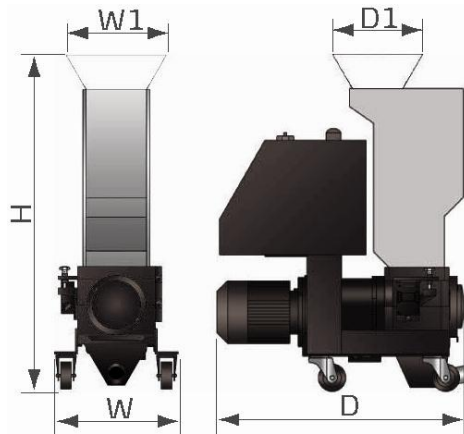

Picture 1-1: Dimensions

1.4 Safety Regulations

Follow the instructions in this manual to avoid personal injury and damage to machine components.

The following safety measures shall be followed when operating the granulator.

1.4.1 Safety Signs and Labels



Electrical installation must only be done by a competent electrician!



Before the granulator is opened for servicing and maintenance, always disconnect the power with both the main switch and the control switch on the granulator.



Never put any part of your body through the granulator openings, unless both the main switch and the control switch on the granulator are in "OFF" position.



High voltage! danger!

This sign is attached on the control box and the wiring box.



Be careful with the rotating knives, they are very sharp and can cause personal injury!



Be careful with the rotating knives, they are very sharp and can cause personal injury!



The granulator should not be able to start before the feed box and screen frame are properly closed.



Attention please!

Ear protection is used during granulating of plastic materials.



SG-14 Granulators cannot deal with fibre added material.



Attention!

No need for regular inspection because all the electrical parts in the control unit are fixed tightly!

When operate the granulator, please notice the following signs.

	<p style="text-align: center;"> Hazard</p> <p>High voltage! May lead to casualty or other serious danger. Please cut off the power before repairing. Circuit diagram should only be changed by professionals. Grounding is necessary.</p>
	<p style="text-align: center;"> Warning</p> <p>Pinch risk when moving belt. Take out or open protective cover is not allowed when it is running.</p>
	<p style="text-align: center;"> Warning</p> <p>There is a pinch risk for this protective cover keep some distance away from that.</p>
	<p style="text-align: center;"> Warning</p> <p>The cutter are very sharp, can cause injury take out or open protective cover is not allowed when it is running. Keep some distance away from the cutters.</p>
	<p style="text-align: center;"> Notice</p> <p>Read the instruction manual carefully before operating. Before start, do the safety device test according to the instruction. It is not allowed to change the design of the machine unless it is approved from the manufacturer.</p>

1.4.2 Transportation and Storage of the Machine

Transportation

- 1) SG-14 series of granulators are packed in plywood cases with wooden pallet at the bottom, suitable for quick positioning by fork lift.
- 2) After unpacked, castors equipped on the machine can be used for ease of movement.
- 3) Do not rotate the machine and avoid collision with other objects during transportation to prevent improper functioning.
- 4) The structure of the machine is well-balanced, although it should also be handled with care when lifting the machine for fear of falling down.
- 5) The machine and its attached parts can be kept at a temperature from -25°C to $+55^{\circ}\text{C}$ for long distance transportation and for a short distance, it can be transported with temperature under $+70^{\circ}\text{C}$.

Storage

- 1) SG-14 series should be stored indoors with temperature kept from 5°C to 40°C and humidity below 80%.
- 2) Disconnect all power supply and turn off main switch and control switch.
- 3) Keep the whole machine, especially the electrical components away from water to avoid potential troubles caused by the water.
- 4) Plastic film should be used to protect the machine from dust and rains.

1.4.3 Working Environment

The machine should be operated:

- 1) Indoors in a dry environment with max. temperature $+45^{\circ}\text{C}$ and humidity no more than 80%.

Do not use the machine:

- 1) If it is with a damaged cord.
- 2) On a wet floor or when it is exposed to rain to avoid electric shock.
- 3) If it has been dropped or damaged until it is checked or fixed by a qualified serviceman.
- 4) This equipment works normally in the environment with altitude within 3000m.
- 5) At least a clearance of 1m surrounding the equipment is required during operation. Keep this equipment away from flammable sources at least two meters.

6) Avoid vibration, magnetic disturbance at the operation area.

1.4.4 Rejected Parts Disposal

When the equipment has run out its life time and can not be used any more, unplug the power supply and dispose of it properly according to local code.



In case of fire, Co₂ dry powder fire extinguisher should be applied.



Flammable materials or materials which are contaminated by flammable substances / liquid may not be processed in the granulator. Serious risk of fire or explosion may cause personnel injury.



It is very important to tighten the screw as required torque.



When process item is longer than feed port, please cut long items into half until the length is shorter before processing.



Please don't put materials into the granulator if they are thinner than 2 mm and are soft and flexible, like rubber.

1.5 Exemption Clause

The following statements clarify the responsibilities and regulations born by any buyer or user who purchases products and accessories from Shini (including employees and agents).

Shini is exempted from liability for any costs, fees, claims and losses caused by reasons below:

1. Any careless or man-made installations, operation and maintenances upon machines without referring to the Manual prior to machine using.
2. Any incidents beyond human reasonable controls, which include man-made vicious or deliberate damages or abnormal power, and machine faults caused by irresistible natural disasters including fire, flood, storm and earthquake.
3. Any operational actions that are not authorized by Shini upon machine, including adding or replacing accessories, dismantling, delivering or repairing.
4. Employing consumables or oil media that are not appointed by Shini.

2. Structural Features and Working Principle

2.1 General Description

SG-14 series are belong to "by the press" granulator, which are designed for grinding different types of plastic waste. The granulator are controlled by main power switch, emergency stop button, start button, stop button and safety switches.

2.1.1 Working Principle

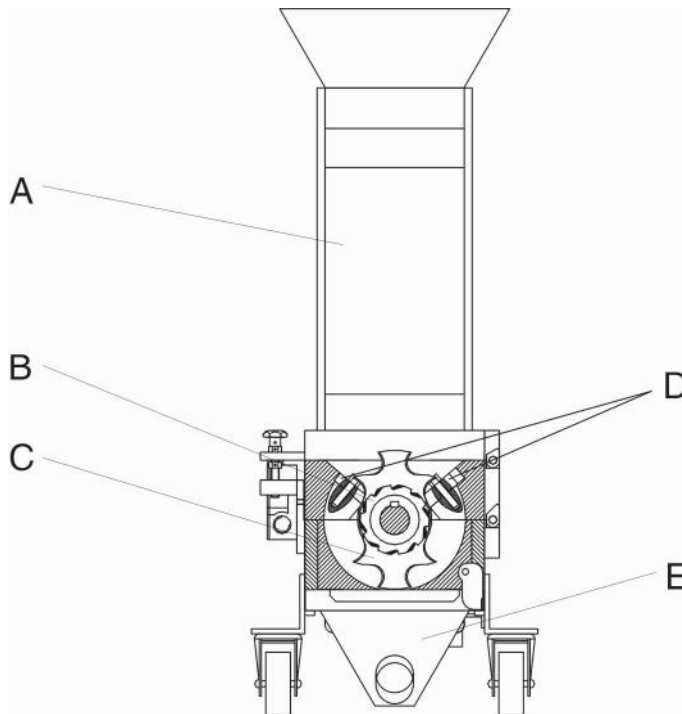

Parts name:

A. Feed box B. Teeth cutter C. Staggered blade D. Fixed blade E. Storage box

Picture 2-1: Working Principle

The material is fed in via a funnel(A) and falls down to the teeth cutters(B), the block material is cutted by the staggered blades(C) and fixed knives(D), then the material is cutted into granule by (B) and (D). The granule directly fall into the storage box(E), it does not need the screen. The cutting chamber is easy to

open for cleaning and maintenance. After this, the granulate is ready for re-use in the production machine, or to be transported to a container for later use.

2.1.2 Safety System

To avoid accidental bodily injury during granulator running, a set of safety system has been designed. High-speed rotating cutter is located in the granulator and subject to accident. So safety system has been set up to protect bodily safety. In any cases, the safety system cannot be changed at random. Otherwise the machine will be under dangerous condition and subject to accident happening. The maintenance and preservation of safety system shall be done by professional staff. In case the safety system of granulator is changed, our company will not perform our commitment. The replacement of all spare parts will be done by SHINI Company.



Safety switch

Picture 2-2: Safety System

2.1.2.1 Emergency Stop Switch

There is one red button on the control panel. Upon pushing it, the machine will stop running. Turn the button in the arrow direction as shown on the button, the button will reset (counter-clockwise).



Emergency stop button

Picture 2-3: Emergency Stop Switch

2.1.2.2 Safety System

On the granulator is equipped the safety position switch for circuit breaker. In case the position of feed box is changed or the breaker is loosened, it will cut off the power supply. There are two safety switches on the granulator: one is located between the feed box and the cutting chamber while the other one is between the storage box and machine body.

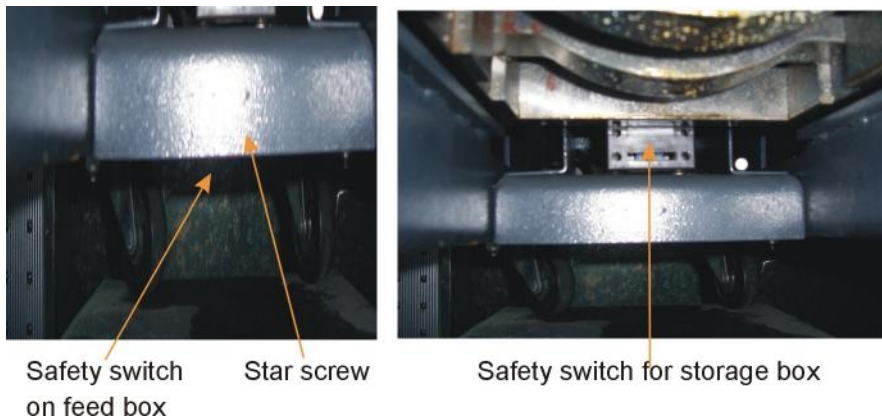

Picture 2-4: Safety System

2.2 Assembly Drawing

2.2.1 Assembly Drawing

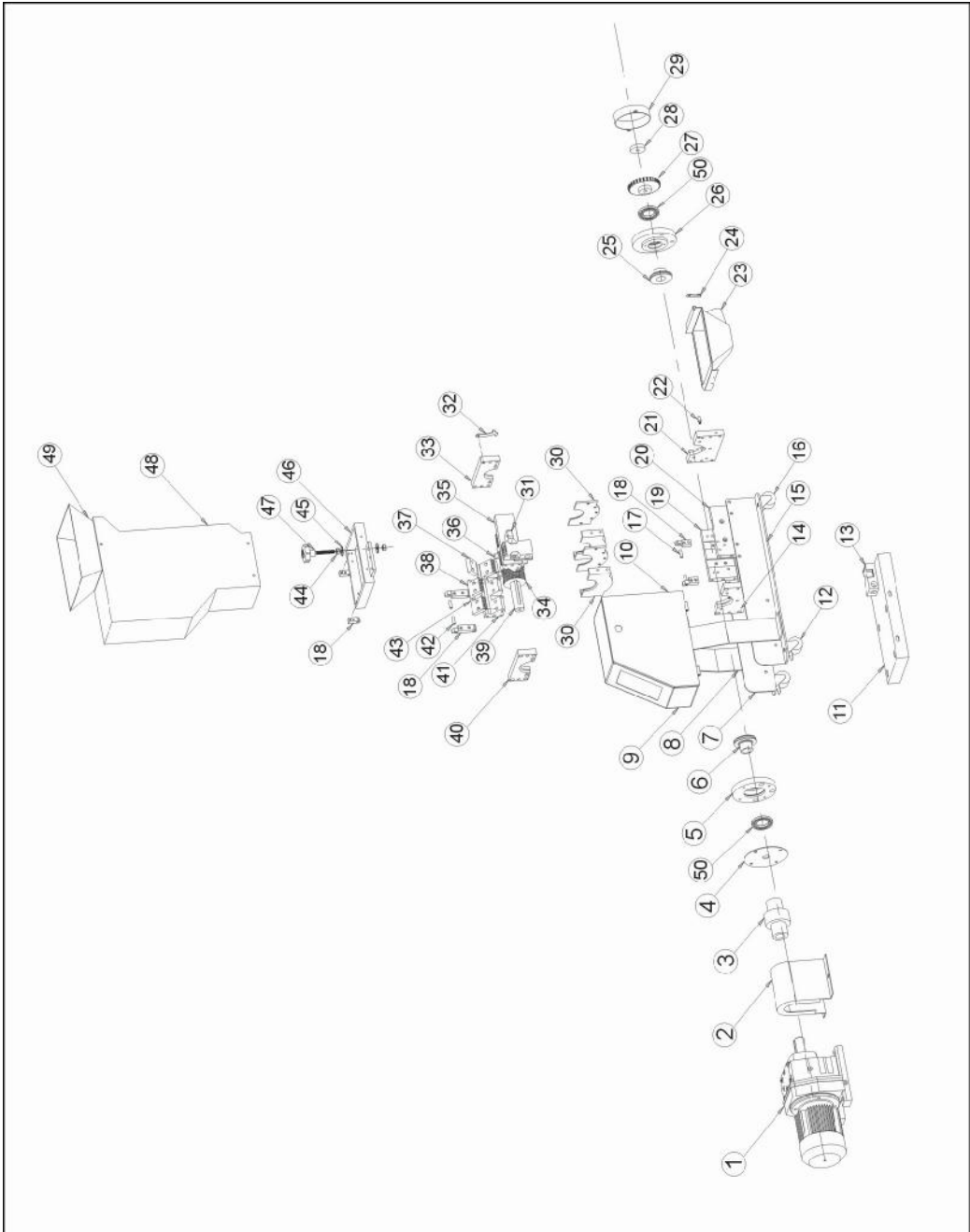

Note: Please refer to 2.2.2 material list about the parts code.

Picture 2-5: Assembly Drawing

2.2.2 Parts list

Table 2-1: Parts List

No.	Name	Part No.	
		SG-1411	SG-1417
1	Gear motor	YM10572100000	YM10572100000
2	Coupling cover	-	-
3	Coupling	YW11305500000	YW11305500000
4	Bearing cover on left side	-	-
5	Left bearing block	BW30001400010	BW30001400010
6	Left bearing sleeve	BW30014000010	BW30014000010
7	Right side fixing plate for castor	-	-
8	Sustain plate for electrical control box	-	-
9	Housing of electrical control box	-	-
10	Top side plate of control box	-	-
11	Fixing plate for gear motor	-	-
12	Turnable castor	YW03002500100	YW03002500100
13	Safety switch**	YE16147600100	YE16147600100
14	Left bearing holder at bottom	BH10140000110	BH10140000110
15	Right side fixing plate for castor	-	-
16	Fixed castor	YW03002500200	YW03002500200
17	Dowel	BH10082700010	BH10082700010
18	Locating block	-	-
19	Back case block at bottom	BH10141100010	BH10141700010
20	Front case block at bottom	BH10141100210	BH10141700110
21	Right bearing holder at bottom	BH10140000010	BH10140000010
22	Pothook	BH10141100110	BH10141100110
23	Storage box	BL51141110020	BL51141710020
24	Check plate for storage box	-	-
25	Right bearing sleeve	BW30001400110	BW30001400110
26	Right bearing block	BW30001420010	BW30001420010
27	Wheel sensor	BH10141101710	BH10141101710
28	Special washer	-	-
29	Wheel sensor cover	-	-
30	Layer	BH10001400510	BH10001400510

No.	Name	Part No.	
		SG-1411	SG-1417
31	Fixing plate for safety switch	-	-
32	Pothook	-	-
33	Right bearing holder at top	BH10140000210	BH10140000210
34	Teeth cutter*	YW40141100300	YW40141700300
35	Front case block at top	YW30141100100	YW30141700100
36	Staggered blade*	YW40141100300	YW40141700300
37	Fixed blade 2*	YW40141100300	YW40141700300
38	Fixed blade 3*	YW40141100300	YW40141700300
39	Main shaft	BH10141101010	BH10141701110
40	Left bearing holder at top	BH10140000310	BH10140000310
41	Back case block at top	BW30141100000	YW30141700000
42	Dowel pin(ϕ 8x32)	BH10083200010	BH10083200010
43	Fixed blade 1*	YW40141100300	YW40141700300
44	Screw nut M10	YW64001000300	YW64001000300
45	Washer	-	-
46	Feed box base	-	-
47	Star knob	YW09001000000	YW09001000000
48	Feed box	YR90141100100	YR90141700000
49	Feed port	BL56141100020	BL56141700020

* means possible broken parts.

** means easy broken part. and spare backup is suggested.

Please confirm the version of manual before placing the purchase order to guarantee that the item number of the spare part is in accordance with the real object.

2.2.3 Cutting Chamber

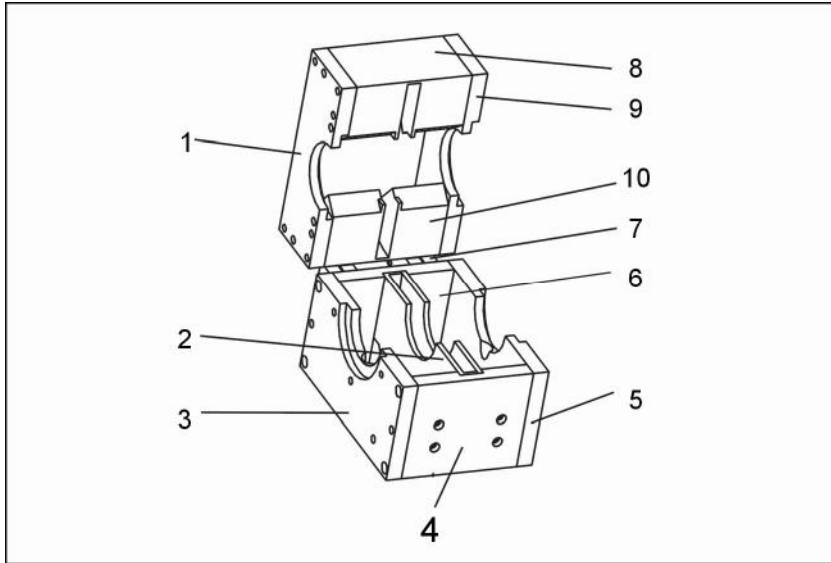

Picture 2-6: Cutting Chamber

2.2.4 Cutting Chamber Parts List

Table 2-2: Parts List

No.	Name	Part No.
1	Left bearing holder at top	1
2	Layer	1-2
3	Left bearing holder at bottom	1
4	Front case block at bottom	1
5	Right bearing holder at bottom	1
6	Back case block at bottom	1
7	Locating block	2
8	Front case block at top	1
9	Right bearing holder at top	1
10	Back case block at top	1

2.2.5 Blade Rest

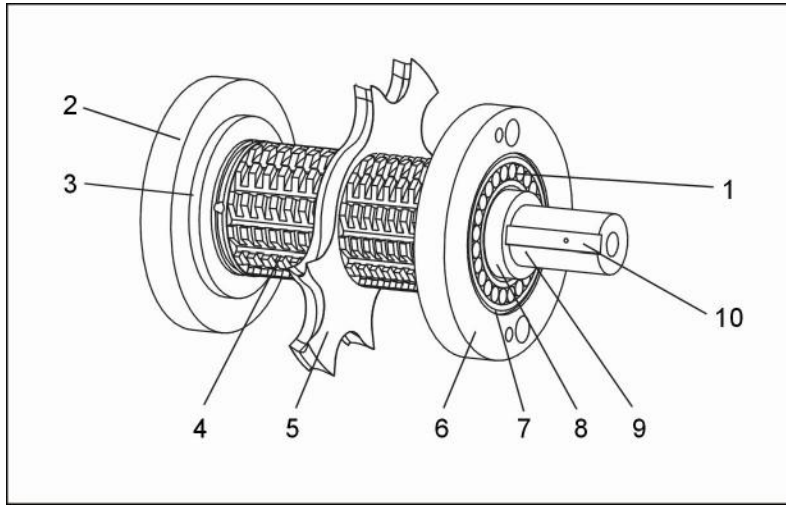

Picture 2-7: Blade Rest

2.2.6 Blade Rest Parts List

Table 2-3: Blade Rest Parts List

No.	Name	Part No.
1	Bearing	2
2	Right bearing block	1
3	Right bearing sleeve	1
4	Teeth cutter	2-3
5	Staggered blade	1-2
6	Left bearing block	1
7	Spring clip	2
8	Left bearing block	1
9	Main shaft	1
10	Key	1

2.2.7 Transmission Parts

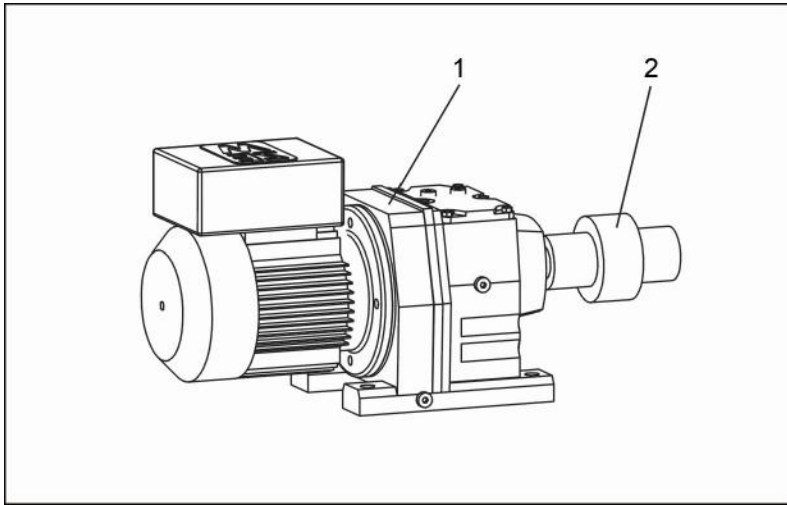

Picture 2-8: Transmission Parts

2.2.8 Transmission Parts List

Table 2-4: Transmission Parts List

No.	Name	Part No.
1	Gear motor	1
2	Coupling	1

2.2.9 Feed Box, Feed Port and Material Stopper

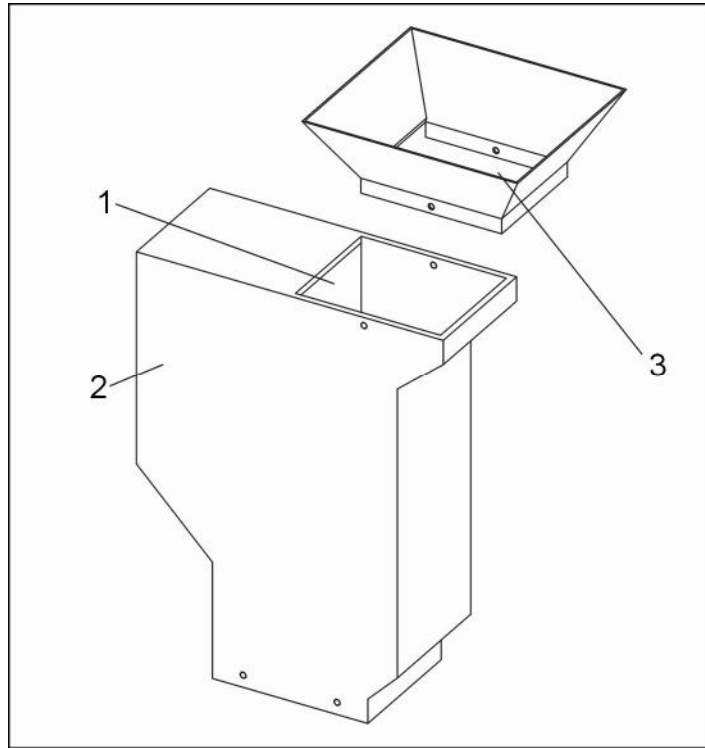

Picture 2-9: Feed Box, Feed Port and Material Stopper

2.2.10 Feed Box, Feed Port and Material Stopper Parts List

Table 2-5: Feed Box, Feed Port and Material Stopper Parts List

No.	Name	Part No.
1	Material stopper	1
2	Feed box	1
3	Feed port	1

2.2.11 Storage Box

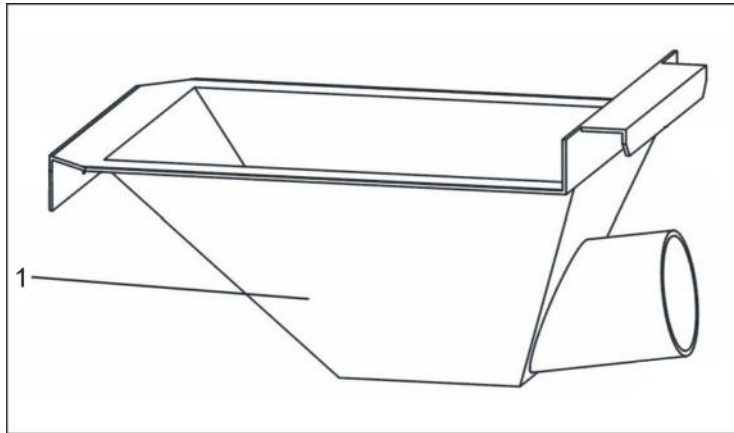

Picture 2-10: Storage Box

2.2.12 Storage Box Parts List

Table 2-6: Storage Box Parts List

No.	Name	Part No.
1	Storage box	1

2.2.13 Main Body

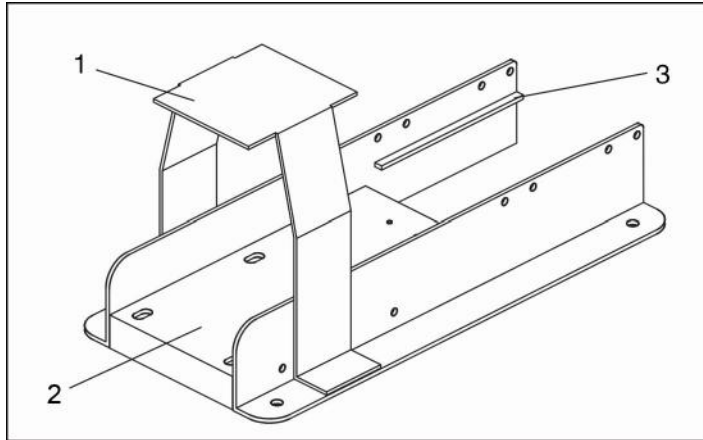

Picture 2-11: Main Body

2.2.14 Main Body Parts List

Table 2-7: Main Body Parts List

No.	Name	Part No.
1	Installation plate for control box	1
2	Installation plate for gear motor	1
3	Fixing plate for storage box	2

2.3 Electrical Diagram

2.3.1 Main Circuit (400V)

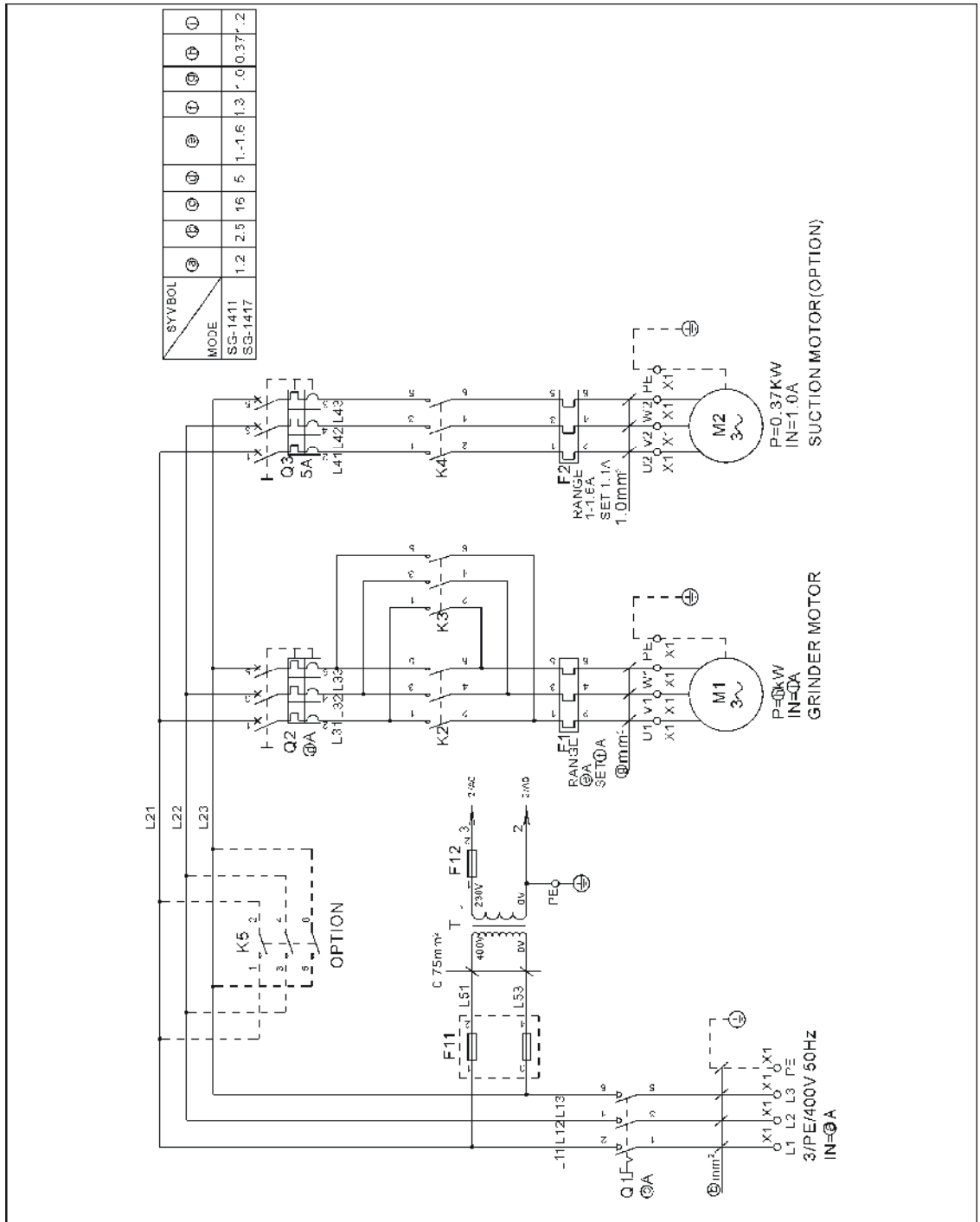

Picture 2-12: Main Circuit (400V)

2.3.2 Control Circuit (400V)

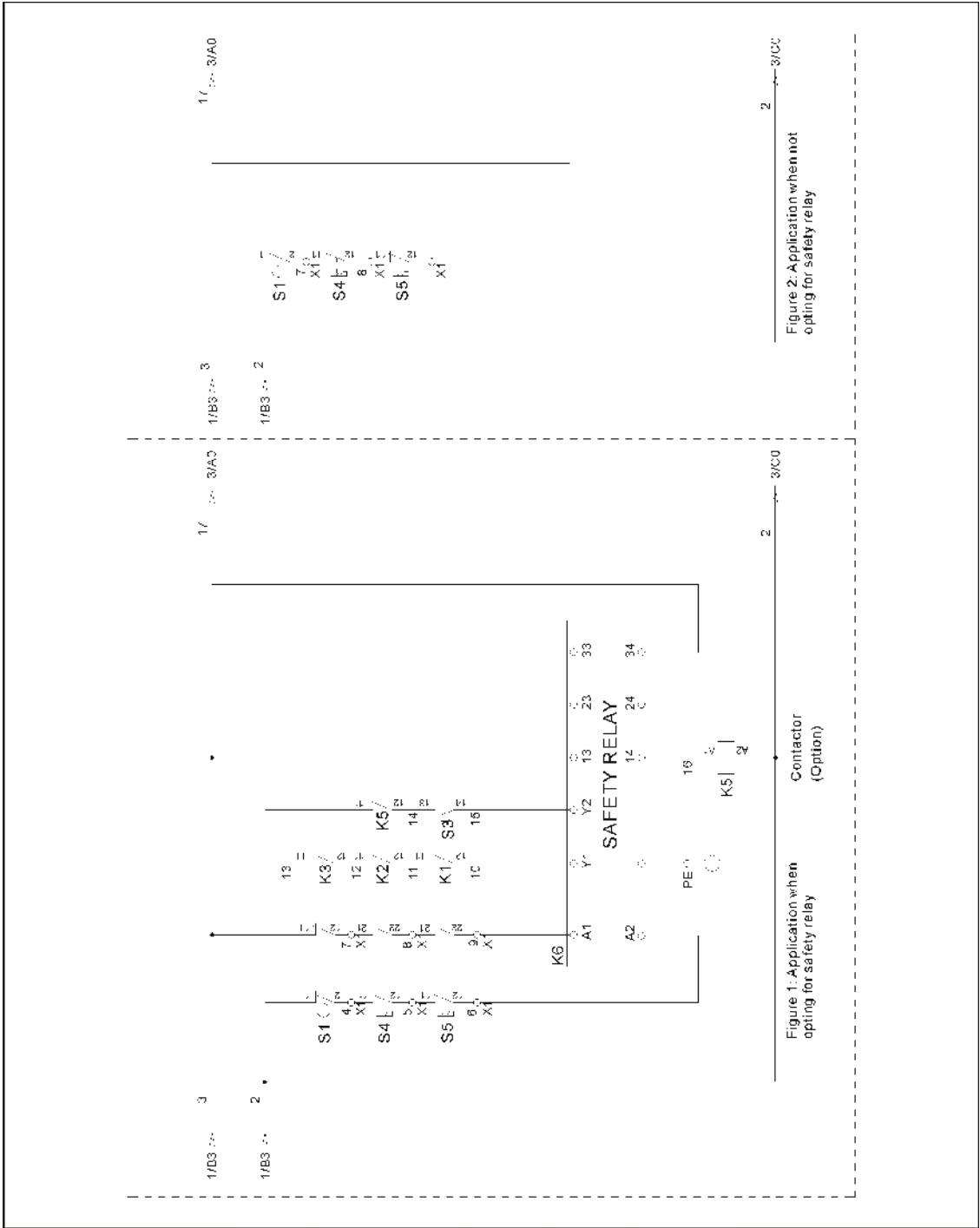

Picture 2-13: Control Circuit 1(400V)

2.3.3 Components Layout (400V)

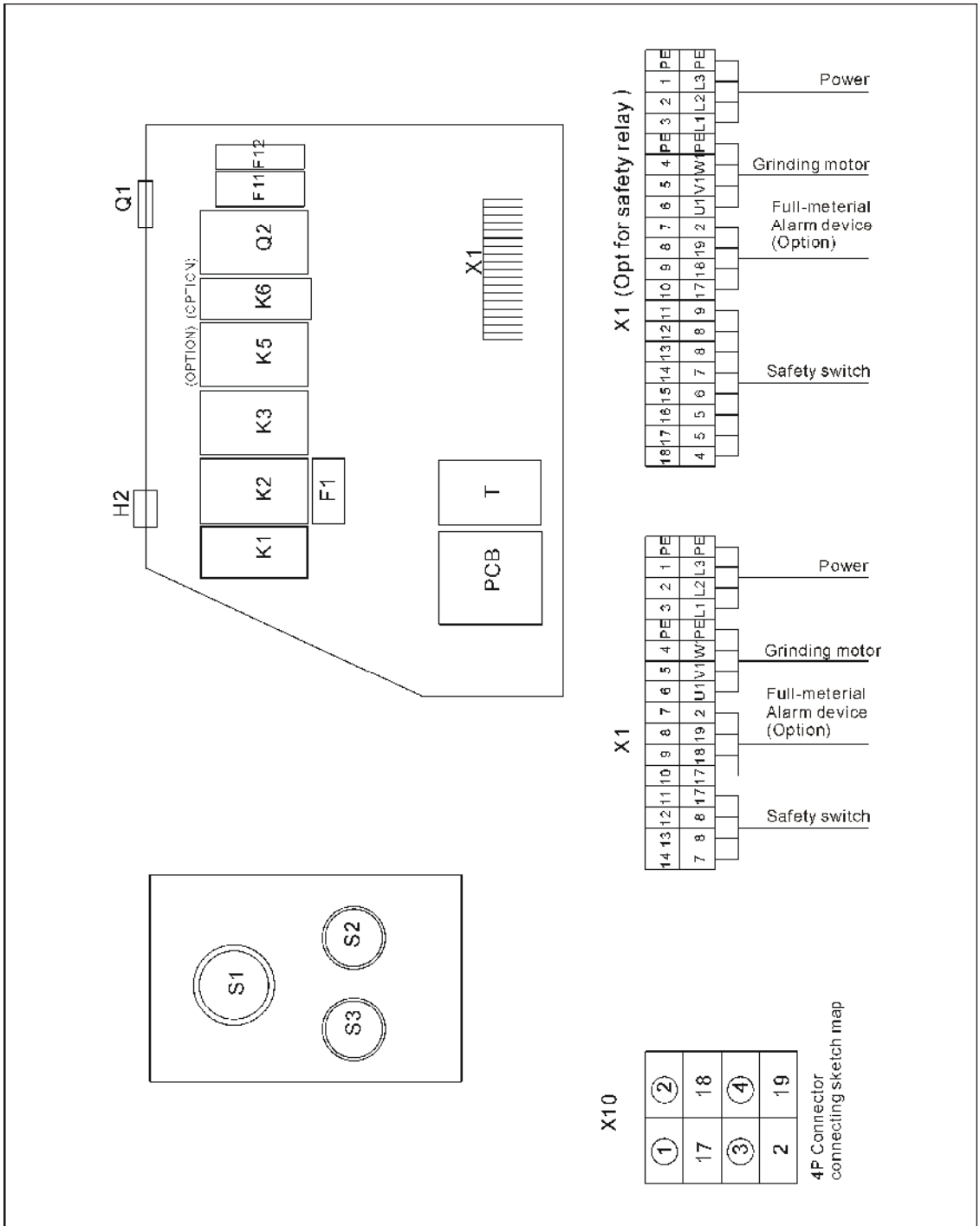

Picture 2-15: Components Layout (400V)

2.3.4 Electrical Components List (400V)

Table 2-8: Electrical Components List (SG-1411/1417) (400V)

NO.	Symbol	Name	Specification	Part NO.
1	Q1	Main switch*	16A 690V 3P	YE10200300000
2	Q2	Circuit breaker*	5A 400V 3P	YE40603000000
3	K1	Middle relay*	230V 50/60Hz	YE03570700000
4	K2 K3	Contact* [*]	230V 50/60Hz	YE00300100000
5	-	Auxiliary contact terminal	1NC	-
6	K5	Contact* [*]	230V 50/60Hz	YE00301000000
7	K6	Safety relay	220V	-
8	F1	Overload relay*	1~1.6A	YE01011600000
9	F11	Fuse**	32A	YE41001000000
10	-	Fuse core	1A	-
11	F12	Fuse**	2A	YE41001000000
12	T	Transformer*	IN=400V OUT=230V 300mA	YE70402300700
13	X1	Terminal	32A	YE61250000000
14	-	-	-	YE61253500000
15		Terminal	32A	YE61250000000
16		Terminal	32A	YE61250000000
17	S1	Emergency stop button	400VAC	YE11320300000
18	S2	Stop button	400VAC	YE11375800000
19	-	Contact block	1NC	-
20	S3 H1	Start button	400VAC	YE11325300000
21	-	Contact block	1NO	-
22	S4 S5	Safety switch	AZ-15	YE16147600100
23	S4 S5	Safety switch	AZ-16	-
24	H2	Alarm lamp	220VAC	YE83305100200
25	H3	Buzzer	220VAC	YE84222000000
26	S6	Sensor*	24VDC NPN	YE15020200000
27	PCB	PCB	230VAC	
28	MS	Feed position motor*	220VAC	YE15000200100
29	X10	Metal tie in	4P	YE10121900000 YE10220600000
30	M1	Granulating motor	400V 50Hz 0.37kW	YM10471000000

* means possible broken parts.

** means easy broken part. and spare backup is suggested.

Please confirm the version of manual before placing the purchase order to guarantee that the item number of the spare part is in accordance with the real object.

2.3.5 Main Electrical Circuit (230V)

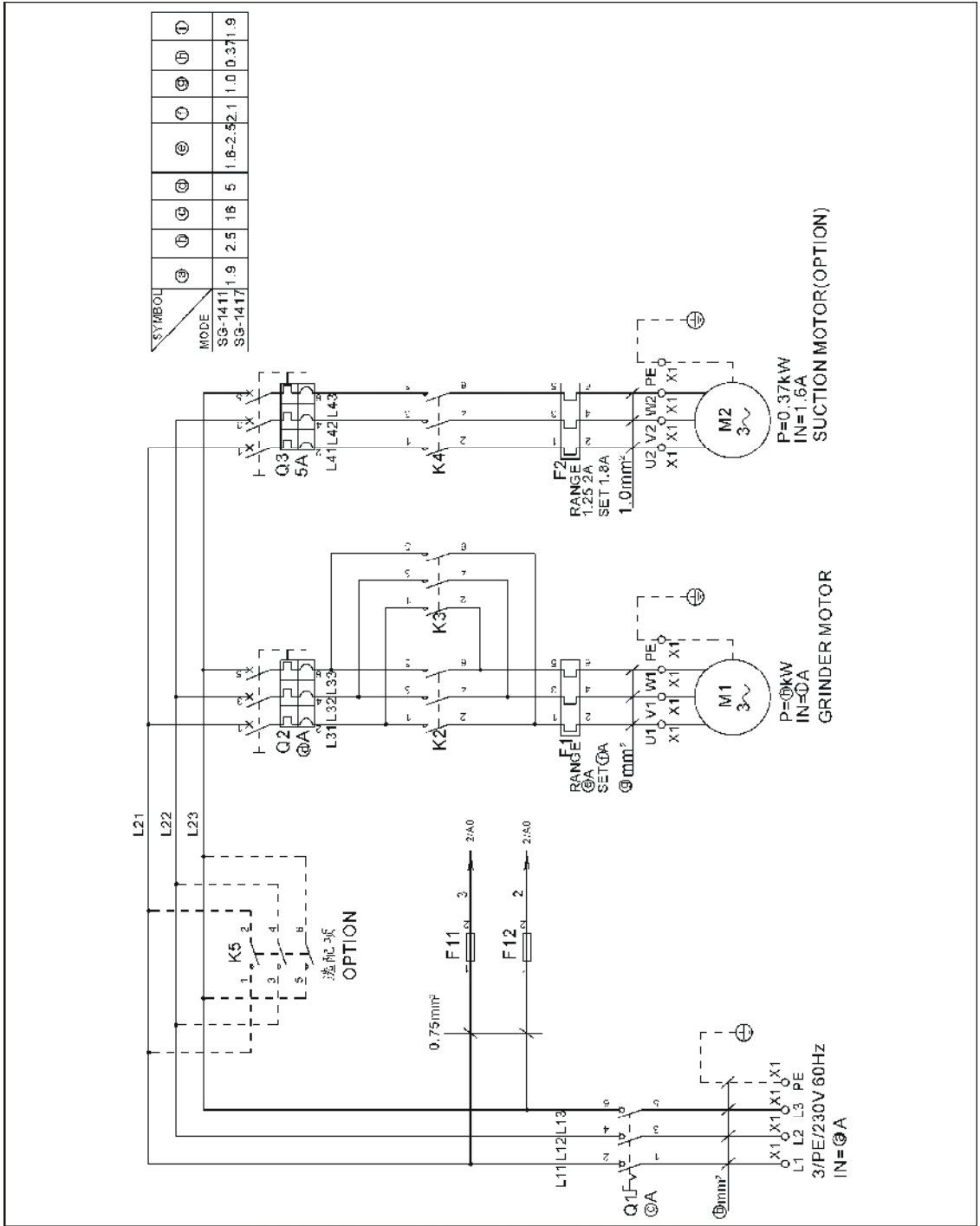

Picture 2-16: Main Electrical Circuit (230V)

2.3.6 Control Circuit (230V)

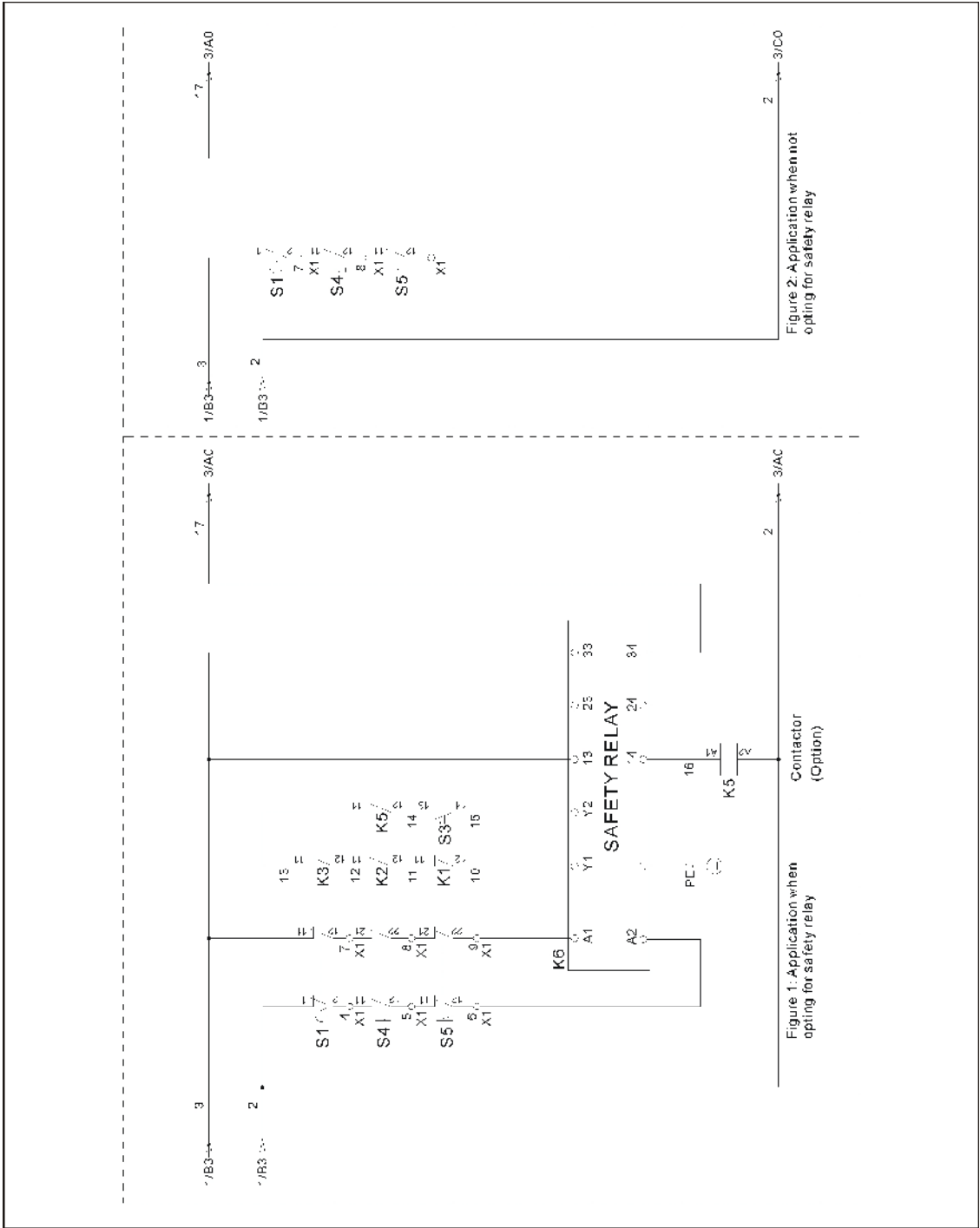

Picture 2-17: Control Circuit 1(230V)

2.3.8 Electrical Components List (230V)

Table 2-9: Electrical Components List (SG-1411/1417) (230V)

No.	Symbol	Name	Specification	Part No.
1	Q1	Main switch*	16A	YE10200300000
2	Q2	Circuit breaker*	5A	-
3	K1	Middle relay*	230V 50/60Hz	YE03570700000
4	K2 K3	Contactor*	230V 50/60Hz	YE00300100000
5		Auxiliary contact terminal	1NC	-
6	K5	Contactor*	230VAC 50/60Hz	-
7	K6	Safety relay	220VAC	-
8	F1	Overload relay*	1.6~2.5A	YE01162500000
9	F12	Fuse**	2A	YE41001000000
10	X1	Terminal	32A	YE61250000000
11	-	-	-	YE61253500000
12	-	Terminal	32A	YE61250000000
13	-	Terminal	32A	YE61250000000
14	S1	Emergency stop button	400V AC12 10A	YE11320300000
15	S2	Stop button	400V AC12 10A	YE11375800000
16	-	Contact block	1NC	-
17	S3 H1	Start button	400V AC12 10A	YE11325300000
18	-	Contact block	1NO	-
19	S4 S5	Safety switch	AZ-15	YE16147600100
20	S4 S5	Safety switch	AZ-16	-
21	S6	Sensor*	24VDC NPN	YE15020200000
22	PCB	PCB	230V	YE80012200200
23	H2	Alarm lamp	220VAC	-
24	H3	Buzzer	220VAC	-
25	MS	Feed position motor*	220VAC	-
26	X10	Metal tie in	4P	YE10121900000 YE10220600000
27	M1	Granulating motor	230V 60Hz 0.37kW	YM10471000000

* means possible broken parts.

** means easy broken part. and spare backup is suggested.

Please confirm the version of manual before placing the purchase order to guarantee that the item number of the spare part is in accordance with the real object.

2.4 Electrical Components Description

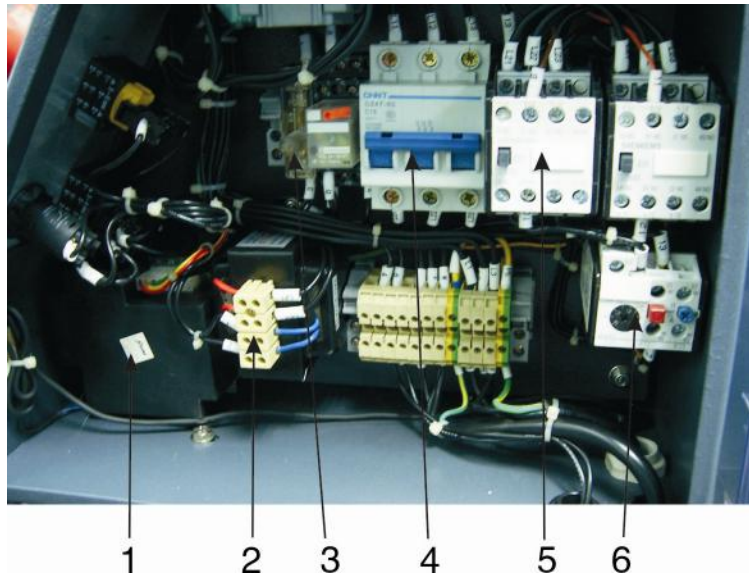

Picture 2-20: Electrical Components Description

1. Reversed PCB.
2. Transformer, provide suitable voltage for control circuit.
3. Fuse, perform the function of overload and short phase protection.
4. Circuit breaker, isolate or short circuit protection.
5. Electromagnetic switch, which can connect or disconnect the power from remote.
6. Overload relay, can protect the motor or phase short.

3. Installation and Debugging



Read through this chapter before installation.



Must abide the following installation steps to avoid personnel injuries or damage of the machine!



Take great care of handing the blades because they are very sharp and may cause cutting injuries!



Power supply of the machine should be handled by qualified electricians!



Be careful!

Cutting blades must be put balanced, prevent it to rotate itself when do the installation. Keep hands from blades to avoid body injuries!



Attention:

Don't take other person's help to finish the installation, use a wooden board to block the rotating blade to finish it.



Notice!

Use protective gloves since the blades are very sharp.



Caution!

Must use new screw and washer to install the blade.

3.1 Installation Notice:

- 1) Make sure voltage and frequency of the power source comply with those indicated on the manufacture's plate, which is attached to the machine.
- 2) Power cable and earth connections should conform with local regulations.
- 3) Use independent power cable and ON / OFF switch. The cable's dia. Should not smaller than those applied in the control box.
- 4) The power cable connection terminals should be tightened securely.
- 5) The machine requires a 3-phase 4-wire power source, connect the power lead (L1, L2, L3) to the live wires, and the earth (PE) to the ground.
- 6) Power supply requirements:
 Main power voltage: $\pm 10\%$
 Main power frequency: $\pm 2\%$

Make at least 1 meter clearance around the machine to facilitate repair and maintenance.



Picture 3-1: Installation Space

Table 3-1: Attached form: cutters and other fixing screw torque

Thread size	M10	M12	M14	M16	M18	M20	M22	M24
Axial force(N)	23.8	34.5	47	65.5	78.5	103	129	149
Fixing torque (Nm)	50	86	135	215	290	420	570	730

3.2 Installation Place

Check and make sure the installation ground is level; there is enough intensity when it is running. Lockup the castors.

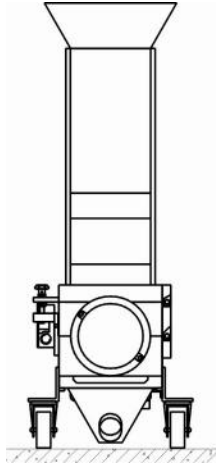

Picture 3-2: Installation Place

3.3 Installation of Bearing and Blade Rest

- 1) Install the bearing 2. bearing washer 1. bearing sleeve 7 into the bearing base 3.
- 2) Insert the blade shaft 4 into the bearing sleeve vertically 7. Then sleeve the staggered blade 5 and the teeth blade 6 on the bearing spacing.

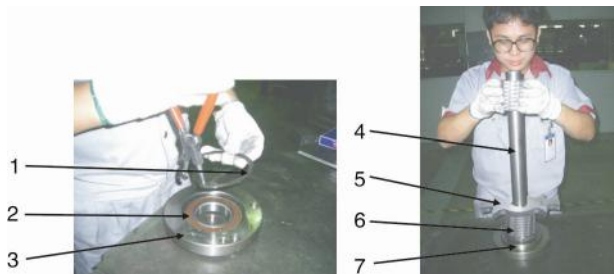

Picture 3-3: Installation of Bearing and Blade Rest 1

- 3) Put the blade rest 2 into the cutting chamber 1, Let both terminal of the bearing tallies with the grooves.



Picture 3-4: Installation of Bearing and Blade Rest 2

4) Fix the bearing base on the cutting chamber.



Picture 3-5: Installation of Bearing and Blade Rest 1 3



Notice!

Daub the lubrication on the bearing and bearing base. Use proper twisting force to lock the screw tightly.

3.4 Installation of Gear Motor and Coupling

- 1) After complete the mounting of blade rest and cutting chamber to the base. Align blade shaft to the grooves on coupling to mount the key and also mount coupling on the blade shaft,
- 2) Put the gear motor on its fixing plate and its connecting key lies in the main shaft groove. Insert main shaft after align itself with coupling. Screw up with four screws (M12x40).



Picture 3-6: Installation of Gear Motor and Coupling



Caution!

To avoid cutters from self-rotating, use a thick wooden block to lock the cutters when install or uninstall the gear motor.



Be careful!

The cutting blade rest shall be put stably. Self turning of cutting tool shall be prevented prior to installation. At the time of operating, hand shall stay away from the cutting tool to avoid bodily injury.

3.5 Installation of Rotating Blade and Fixed Blade

- 1) Install the bearing 2, bearing washer 1, bearing sleeve 7 into the bearing base 3.
- 2) Insert the blade shaft 4 into the bearing sleeve vertically 7. Then sleeve the staggered blade 5 and the teeth blade 6 on the bearing spacing.

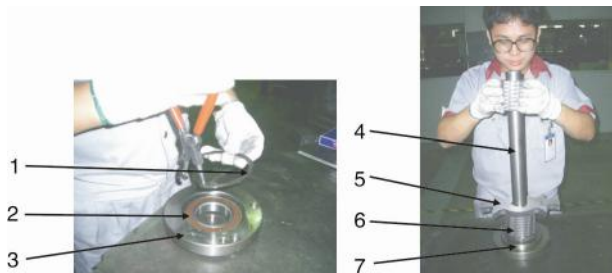

Picture 3-7: Installation of Rotating Blade and Fixed Blade 1

- 3) Put the rotating blade rest at the bottom block of the cutting chamber and align its holes with the holes on cutting chamber.



Picture 3-8: Installation of Rotating Blade and Fixed Blade 2

- 4) Use a wrench to tight up all the screws on bearing block or cutting chamber and lock them up with right torque (M12x25).

5) After installed the rotating blade rest to the housing, mount fixed blades that correspond with teeth cutters on pressing block and align their holes. Lockup the fixing screw (LOCTITE243 thread fixing glue is recommended). (Fixing screw for front fixed blade is M10x30, while for back fixed blade is M10x35).



Picture 3-9: Installation of Rotating Blade and Fixed Blade 3



Caution!

Because it is unable to adjust the space between rotating blade and fixed blade, so please rotate the blade rest after installed all blades to check if it is rotating normally for least of cutter damage!



Caution!

In order to avoid personal injury and machine damage, the lockup screws has to be tightened.

3.6 Installation of Feed Box, Feed Port and Storage Box

1) Lift up the feed box 1 to fix it onto the cutting chamber with screws (M8×35).

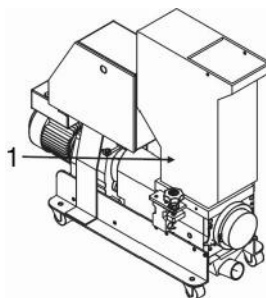

Picture 3-10: Installation of Feed Box, Feed Port and Storage Box 1

2) Hold the feed port 2, and insert it into the feed box.

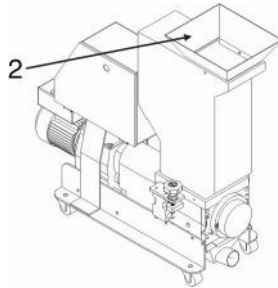

Picture 3-11: Installation of Feed Box, Feed Port and Storage Box 2

- 3) Before fixing the feed port, place the plastic strips at the top of feed box and let feed port press against it.
- 4) Lay down the feed port and align its screw holes with the screw holes on the feed box, then lock the screws up (M8×20).
- 5) Hold the storage box with both hands and push it into its right position along the slide way.

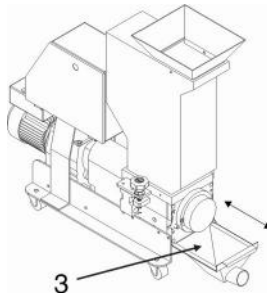

Picture 3-12: Installation of Feed Box, Feed Port and Storage Box 3



Caution!

When mount the storage box, push along the slideway to the end or its safety switch could not be fully closed.

4. Operation Guide



Wear gloves during operating to avoid personal injury!



Wear goggles during operating to avoid personal injury!

4.1 Startup Pretest

Unpainted part of the machine has been covered with stainless oil. Before use, the stainless oil should be cleaned.

- 1) Clean with a towel.
- 2) Wash with a towel dipping with amyl acetate.

4.1.1 Before the First Startup

- 1) Check whether the granulator is in the level state.
- 2) Check the space of the cutting tools to see whether the lockup screws of the blades are tightened (torque: 280Nm).



Caution!

Adjust the machine to let its four castors share the whole weight and in level state.

4.1.2 After Startup for 2 Hours

- 1) Check the space of the cutting tools of the fixed blades and rotating blades again; check whether the lockup screws of the blades are loose.
- 2) Check the position-adjusting screws of the motor and check whether the position-adjusting screws are tightened.

4.2 Circuit Connection

The installation of the granulator's circuit must be conducted by the professional electricians.

- 1) Connect granulator to the power.
- 2) Connect the transmission belt clockwise.

4.2.1 Check the Running Direction of the Motor

- 1) Open the door to check whether the feed box is closed.
- 2) Ensure the main power switch is in ON position.
- 3) Check the emergency stop.
- 4) Start the granulator via pressing the START button and stop the granulator via pressing the STOP button.
- 5) The granulator needs some time to fully come to a halt; after full stop, check whether the running direction is clockwise.



Caution!

The cutting tools may be damaged and the granulating capability will be reduced if there is a wrong running direction. Please disconnect the power and transpose any two wires of the three in the main power.

4.3 Open the Feed Box and Storage Box



Before opening the feed box and the storage box, turn off the main power switch and the power switch of the granulator.



Be careful! The blade is very sharp, please take care.

4.3.1 Open the Feed Box

- 1) Check if the feed box has been emptied. If so, turn off the main power switch.
- 2) Loosen the long star screw and open the feed box.



Picture 4-1: Open the Feed Box

4.3.2 Open the Storage Box

- 1) Shut off the power of granulator.
- 2) Remove the storage box.



Picture 4-2: Open the Storage Box

4.4 Shut the Feed Box and Storage Box

4.4.1 Shut the Feed Box

- 1) Check to ensure there is no powder left in the interface or corners.
- 2) Close the feed box forwardly.
- 3) Lock up the star screw and fix the feed box.

4.4.2 Shut the Storage Box



Note!

Before closing, clean the interface surface.

Be careful!

Don't get squeezed and injured.

- 1) Check no powder or leftover material around the storage box; timely remove them if any.
- 2) Push the storage box into along its slideway.

4.5 Start and Stop the Granulator

The granulator is controlled by main power switch, safety switch, START/STOP button and emergency stop button.

Main power switch:

It is located at the front control panel. Through rotating the switch to control the startup and stop of the machine.



Picture 4-3: Main Power Switch

START button and STOP button:

These two buttons control the startup and stop of the machine.

Emergency stop:

When an accident happens, this button can do a favor.



Main power switch
Emergency stop button
Start button
Stop button

Picture 4-4: START, Emergency Button and STOP Button



Caution!

If there are ungrinded crew materials in the feed box or cutting chamber, the granulator shall NOT be stopped, otherwise the crew materials will blockade the rotor and the motor will be overloaded next time you start the machine up.

4.6 Motor Reversed Protective Function

When there are hard material appear in the feed box and cutting chamber or for other reason the cutting blades can not cut, this unit will enable blade shaft reverse rotating with alarm, It resumes normal operation automatically after 3 seconds later, so to keep granulating material. The alarm die out after blade shaft rotates normally. If the motor reverse function be started over 3-4 times or more, the motor would be stopped. At this time you can press down the STOP button to cut off the power, and then restart it by press the START button.

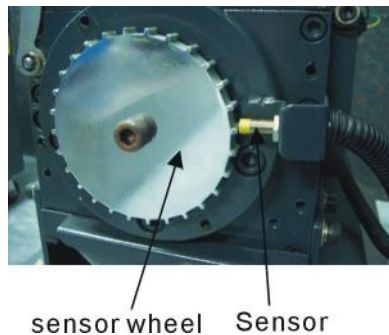

Picture 4-5: Motor Reversed Protective Function

If the rotor has been seized during operation, its working mode is :

Rotor is seized up, auto stop for 1 sec → reverse rotate for 3 secs → stop for 1 sec → normal rotate →

A. 1) normal → working

2) seized up → stop for 1 sec → reverse rotate for 3 secs → stop for 1 sec → normal rotate

B. 1) normal → working

2) seized up → stop for 1 sec → reverse rotate for 3 secs → stop for 1 sec → normal rotate

C. 1) normal → working

2) seized up → machine stops



Mount sensor and ensure its space with big wheel to about 2~4mm.

5. Trouble-shooting

5.1 Granulator Can Not Work

- 1) Check if the emergency stop has not been reset. If not, rotate the Button anti-clockwise to reset it.
- 2) Check whether the door is closed. If not, the machine could not be started.
- 3) Check if the feed box is completely closed. If not, the machine could not be started. Then, check the lockup clip after opening the door.
- 4) Check the motor's overload protector. The overload protector in the electrical control box will work if the motor overloads. Under that situation, (A) (the green pole) will sprout. Press the Reset button (B) to reset it. Before startup again, check whether there is any powder in the granulator.
- 5) Check the overload protector of the feeding blower's motor. If the feeding blower does not run, the granulator cannot run either. Check the motor protector in the electric control box. If it is closed, the switch will be in 0 positions. Reset it to 1 position. (A) (The green pole) will sprout. Press the Reset button (B) to reset it.
- 6) Check the space between blades A stop will happen or the motor overload protector will work if the blade is very blunt or the space between blades is not correct. More details about checking, replacing and readjusting the blades to see chapter 3.3.



5.2 Stop Due to Other Reasons

Connection failure or looseness of safety switch or limit switch can also result in operation failure.



Note!

Do not disconnect to safety switch or control switch.

6. Maintenance and Repair

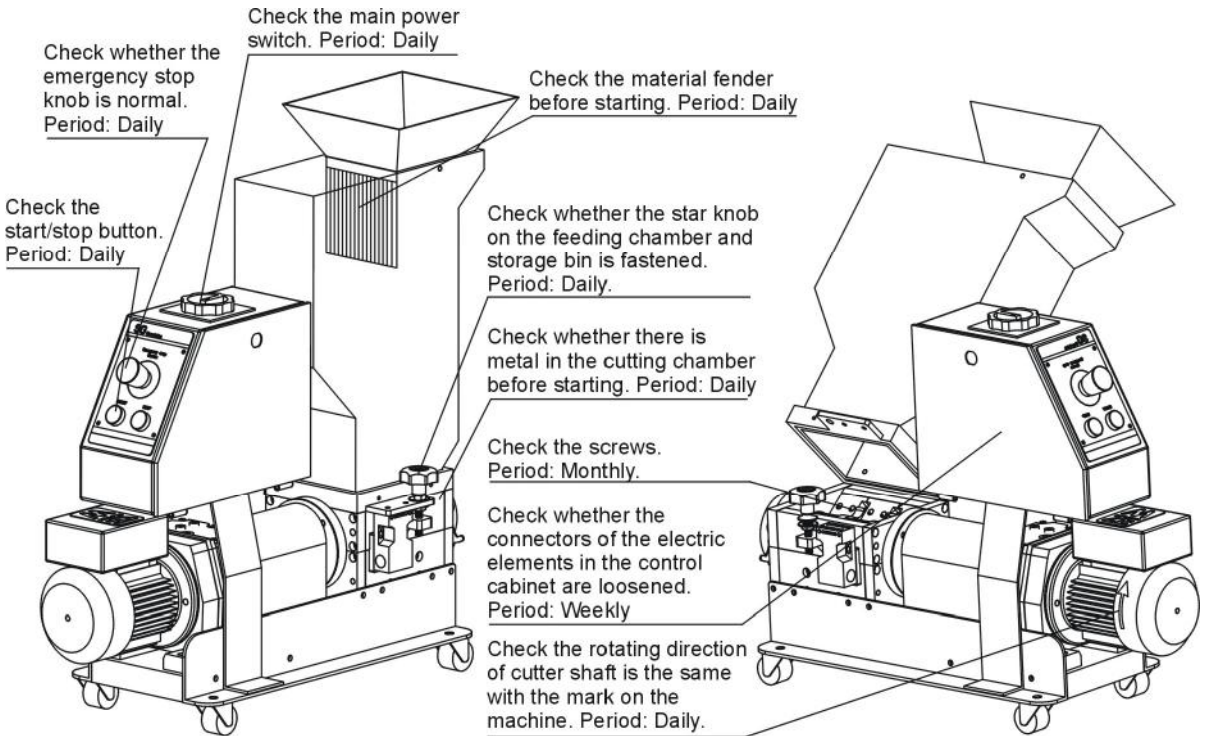

6.1 Repair

All the repair must be done by professionals to avoid damage to machine and harm to human body.

6.1.1 Replace the Blades



Caution!

Warning: Self-rotation exists due to non-balanced forces or unstable bary center.



Wear gloves to avoid being cut and be careful of the sharp blades!

More details about replacing or maintaining the blades to see chapter 3.5. Inject screw thread fixing glue (light blue LOCTITE 243 recommended) to the fixing screw so to avoid slipping and tighten screws up.



Picture 6-1: Replace the Blades



Caution!

To decrease the possibility of harm to other people, the replacement action must be conducted by oneself.



To avoid self-rotation, block the rotating blades with a thick wood block.

Be careful with the sharp blades.



Each time to replace the blade, the screw and insulation ring must be replaced also.

1) Remove the fixed blades



Caution!

To avoid self rotation, block the rotating blade with a thick wood block.

1. Remove the screws.
2. Remove the fixed blades.
3. Clean the installation surface of the blades.

2) Remove the rotating blades

1. Open the cutting chamber and take out the blade rest.
2. Loosen and remove the hexagon socket cap screw.
3. Clean the whole rotating blades and cutting chamber.



Caution!

Press the pressing block and blade when you remove the last screw so to avoid personal injuries.

3) Install the blades

Clean carefully the fixed blades and rotating blades and then install them.



Caution!

Each time to replace the blade, the screw and insulation ring must be replaced also. Install the rotating blades, then the fixed blades, finally the front fixed blades. More details about replacing or maintaining the blades to see chapter 3.6.

6.2 Maintenance

When carrying out maintenance, ensure that there is no material left in the granulator.



Caution!

All stuff concerning repair must be conducted by professionals to avoid damage or harm to human body.

6.2.1 Daily Check

- 1) There is rubber shutter in the feed box. If the rubber shutter is damaged, replace it immediately. Otherwise the fragment of the shutter will damage the blades in the cutting chamber.
- 2) Check whether the Emergency Stop works properly. Start the machine and then stop it via Emergency Stop. Rotate the button an ti-clockwise to reset the Emergency Stop.
- 3) Check the main power switch, start/stop button.
- 4) Check the reversed rotating function.
- 5) Check star screw, safety screw is part of granulator' safety system, its length is pre-designed, when the screw is loosen, the granulator will stop working so to protect the machine. The thread length of the safety screw is 60mm, damaged screw needs to be replaced by a new one.



Picture 6-2: Star Screw

6.2.2 Weekly Check

- 1) Check the power wire to see whether there is any damage. If so, replace it immediately.
- 2) Check the safety switch.

6.2.3 Monthly Check

Check the gear motor's working condition.

6.2.4 Check and Maintenance of Gear Motor

Check lubricating oil for every six months or after 3000 hours in operation

1) Check oil level:

1. Cut power off so to avoid electric shock and wait till the gear motor get cooled.
2. Remove oil level plug to check if the oil has been filled up full.
3. Install oil level plug.

2) Check the lubricating oil:

1. Cut power off so to avoid electric shock and wait till the gear motor get cooled.
2. Open the oil drainage plug to get oil sample.
3. Check viscosity index of the lubricating oil.
If it is evidently turbid, please replace it as soon as possible.
4. Check the lubricating oil level and install oil level plug.

3) Lubricating oil replacement:

Increased viscosity of the lubricating oil will make it harder to discharge the oil, so better replace it when the gear motor is in its operational temp.

- 1) Cut power off so to avoid electric shock and wait till the gear motor get

cooled and there is no potential burning danger!

- 2) Lay an oil pan under the oil drainage plug.
 - 3) Open the oil level plug, air valve and oil drainage plug.
 - 4) Drain all the lubricating oil out.
 - 5) Install oil drainage plug.
 - 6) Fill in new lubricating oil in same brand.
 - 7) Tight up the oil level plug and air valve.
- 4) Brand of lubricating oils (ambient temperature : $-10^{\circ}\text{C}\sim 40^{\circ}\text{C}$):
- | | |
|---------|----------------------|
| Mobil: | Mobilgear 630 |
| Shell: | Shell Omala 220 |
| Aral: | Aral Degol BG 220 |
| BP: | BP Energol GR-XP 220 |
| Texaco: | Meropa 220 |

6.3 Cleaning



Caution: The blade may do harm to human body when opening the feed box!

- 1) Check whether the feed box is emptied before stopping the machine.
- 2) Clean the exterior surface of the feed box.
- 3) Turn off the main power switch.
- 4) Clean the shutter of the feed box with a dust separator.
- 5) Clean both surfaces of the cutting chamber; open the upper cutting chamber and to clean the remain material by using revolving rod to turn the blade shaft.
- 6) Screw off the star knob to open the feed box backwardly.
- 7) Clean the interior surface of the feed box.
- 8) Clean the screen frame and the screen.
- 9) Uninstall the storage box and clean it.
- 10) Clean the belt pulleys with bright dust-precipitator.

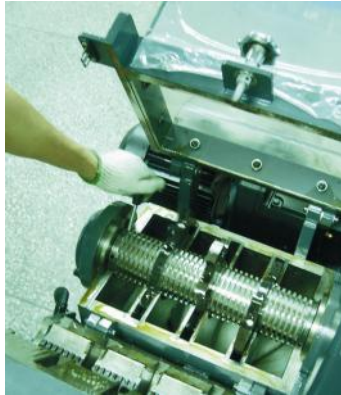

Picture 6-3: Cleaning



Do step 5 for every time of machine cleaning and also it at least has to be done for one time after 300 hours in operation.

6.4 Maintenance Schedule

6.4.1 About the Machine

Model _____ SN _____ Manufacture date _____

Voltage _____ Φ _____ V Frequency _____ Hz Power _____ kW

6.4.2 Check After Installation

- Check if pipe connections are firmly locked by clips.
- Check the gap between fixed blade and rotating blade.
- Check the rotating balance of the belt wheel.

Electrical Installation

- Voltage: _____ V _____ Hz
- Specs of the fuse: 1 Phase _____ A 3 Phase _____ A
- Check phase sequence of the power supply.
- Check the rotating direction of the conveying blower.

6.4.3 Daily Check

- Check main power switch.
- Check emergency stop button.
- Check start / stop button.
- Check material check plate (strip) is perfect or not.
- Check whether emergency stop and safety switch works normally.
- Clean feed box.
- Check whether start, stop and power switches are normal.

6.4.4 Weekly Check

- Check all the electrical cables.
- Check if there are loose connections of electrical components.
- Check blade condition.
- Check whether set screws in fixed and rotate blades are under looseness.
- Check if there is abnormal noise, vibration and heat in reduction gear.
- Check the cracking window

6.4.5 Monthly Check

- Check the status of the belt.

- Check the overload protection function of the motor.
- Check motor reversed running function.
- Check the tightness of the blades.

6.4.6 Check Half-yearly or Every 1000 Running Hours

- Check or replace lubrication for gear motor.
- Check lubrication of bearing.
- Check coupling.
- Evaluation of the machine condition.

6.4.7 3 year Checking

- PC board renewal.
- No fuse breaker renewal.