

1. Assembly Drawing (SAL-700G)

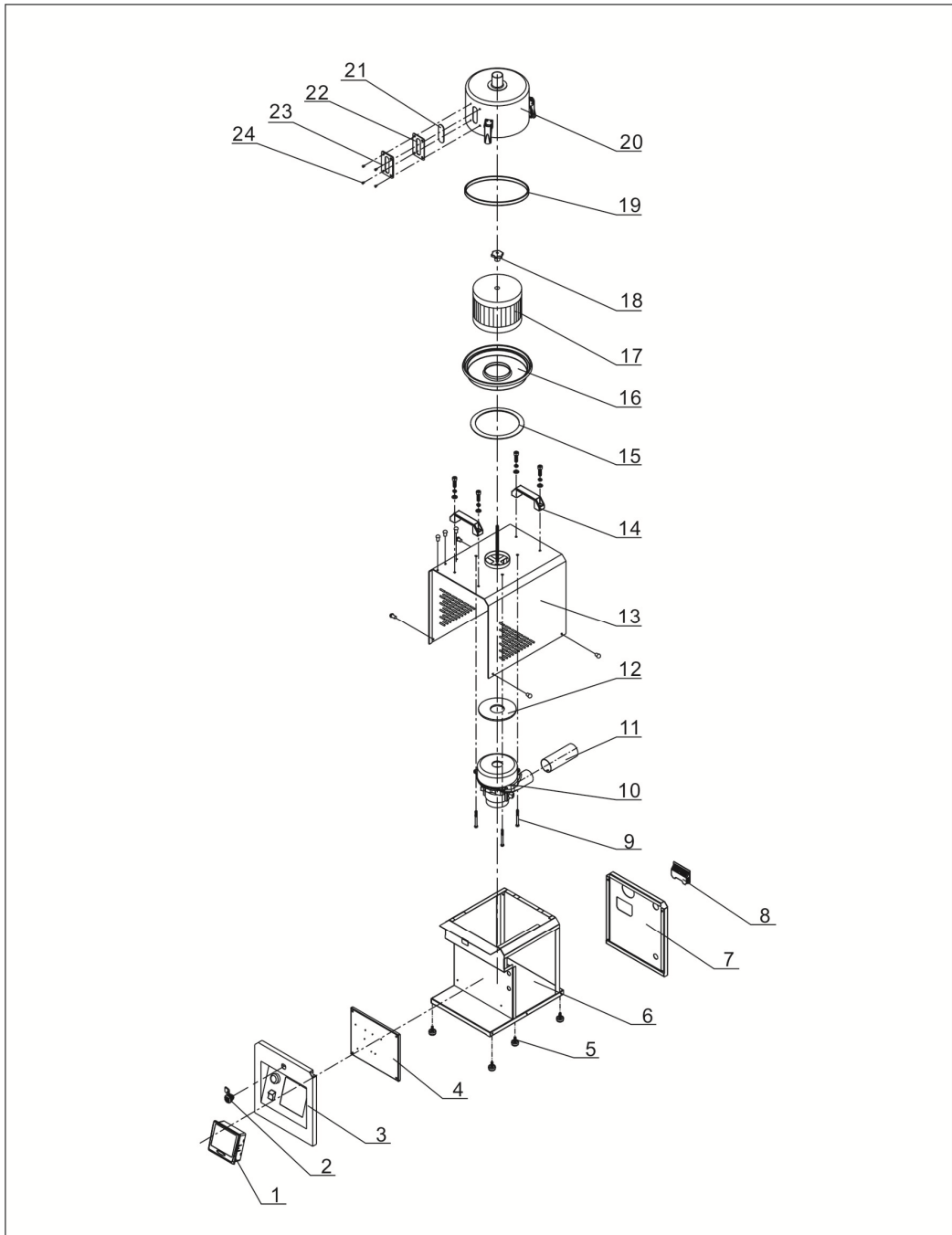

Remarks: Please refer to material list 2 for specific explanation of the Arabic numbers in parts drawing.

2. Parts List (SAL-700G)

No.	Name	Part No.
1	Control box	-
2	Door lock	YW00000600000
3	Door plate	-
4	Electric fixing plate	-
5	Foot pad $\Phi 30 \times 17$	YR40301740000
6	Outer frame assembly	-
7	Rear plate	-
8	RS485 Shell	YR40048500000
9	Inner hexagon column screw M6X65	YW61066500100
10	Carbon brush motor	YM30119625000
11	Air exhaust pipe	BL22701500020
12	Motor fastener	YP62141200000
13	Cover	-
14	Aluminum square handle L120	BW20012000040
15	Filter base fastener	YR10135500000
16	Filter barrel cover	-
17	Filter	YR50708000100
18	Star nut 5/16"	YW09051600000
19	Filter barrel fastener	YR10080000300
20	Filter barrel	-
21	Four-hole acryl	YR40001200100
22	Four-hole sight glass fastener	YR40000400000
23	Four-hole sight glass	YW09000000400
24	Cross recessed pan head screw M5X10	YW62051000100

* means possible broken parts.

** means easy broken parts and spare backup is suggested.

Please confirm the version of manual before placing the purchase order to guarantee that the item number of the spare part is in accordance with the real object.

3. Assembly Drawing (SAL-810G/820G/830G)

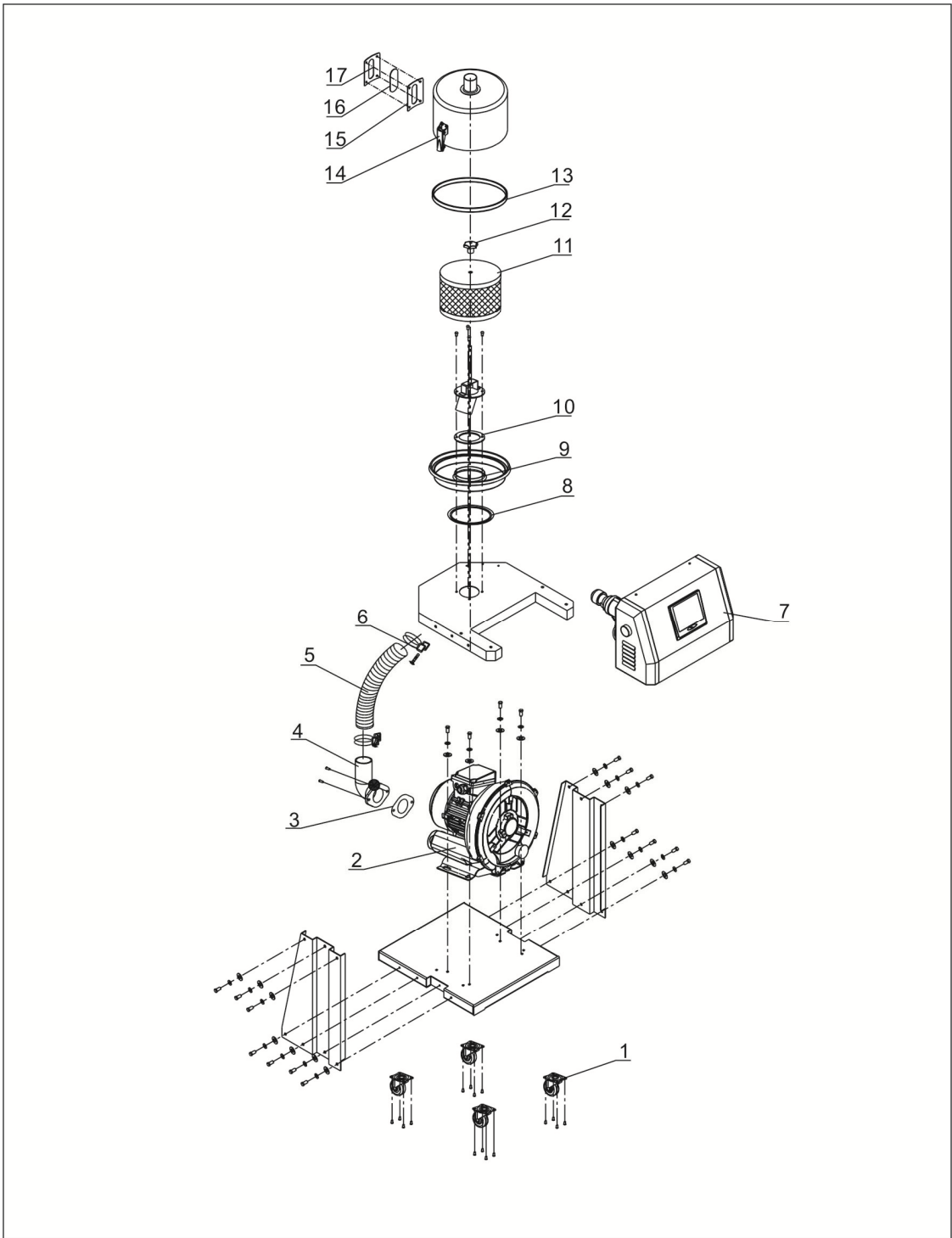

Remarks: Please refer to material list 4 for specific explanation of the Arabic numbers in parts drawing.

4. Parts List (SAL-810G/820G/830G)

No.	Name	Part No.		
		SAL-810G	SAL-820G	SAL-830G
1	Black castor 2"	YW03000200000	YW03000200000	YW03000200000
2	High-pressure blower	BM30031000150	BM30042000050	BM30053000050
3	Motor air inlet fastener	YR1000100000000	YR1000200000000	YR1000200000000
4	Air suction pipe elbow	YR40004700000	YR40002000000	YR40002000000
5	Steel wired plastic pipe 2" (0.35m)	YR60500700100	YR60500700100	YR60500700100
6	Steel wire hose 2"	YW02005700000	YW02005700000	YW02005700000
7	Control box (400v)	BH32081000150	BH32081000150	BH32081000150
8	Fastener *	YR10080000000	YR10080000000	YR10080000000
9	Filter barrel cover	BL20070000720	BL20070000720	BL20070000720
10	Fastener of material inlet pipe	YR10243600000	YR10243600000	YR10243600000
11	Filter	YR50708000100	YR50708000100	YR50810400000
12	Star nut 5/16	YW09675100000	YW09675100000	YW09675100000
13	Filter barrel fastener	YR10080000300	YR10080000300	YR10080000300
14	Snap hook	YW02003000400	YW02003000400	YW02003000400
15	Four-hole sight glass fastener *	YR40000400000	YR40000400000	YR40000400000
16	Four-hole acryl	YR40001200100	YR40001200100	YR40001200100
17	Four-hole sight glass	YW09000000400	YW09000000400	YW09000000400

* means possible broken parts.

** means easy broken part. and spare backup is suggested.

Please confirm the version of manual before placing the purchase order to guarantee that the item number of the spare part is in accordance with the real object.

5. Assembly Drawing (SAL-900G/G2)

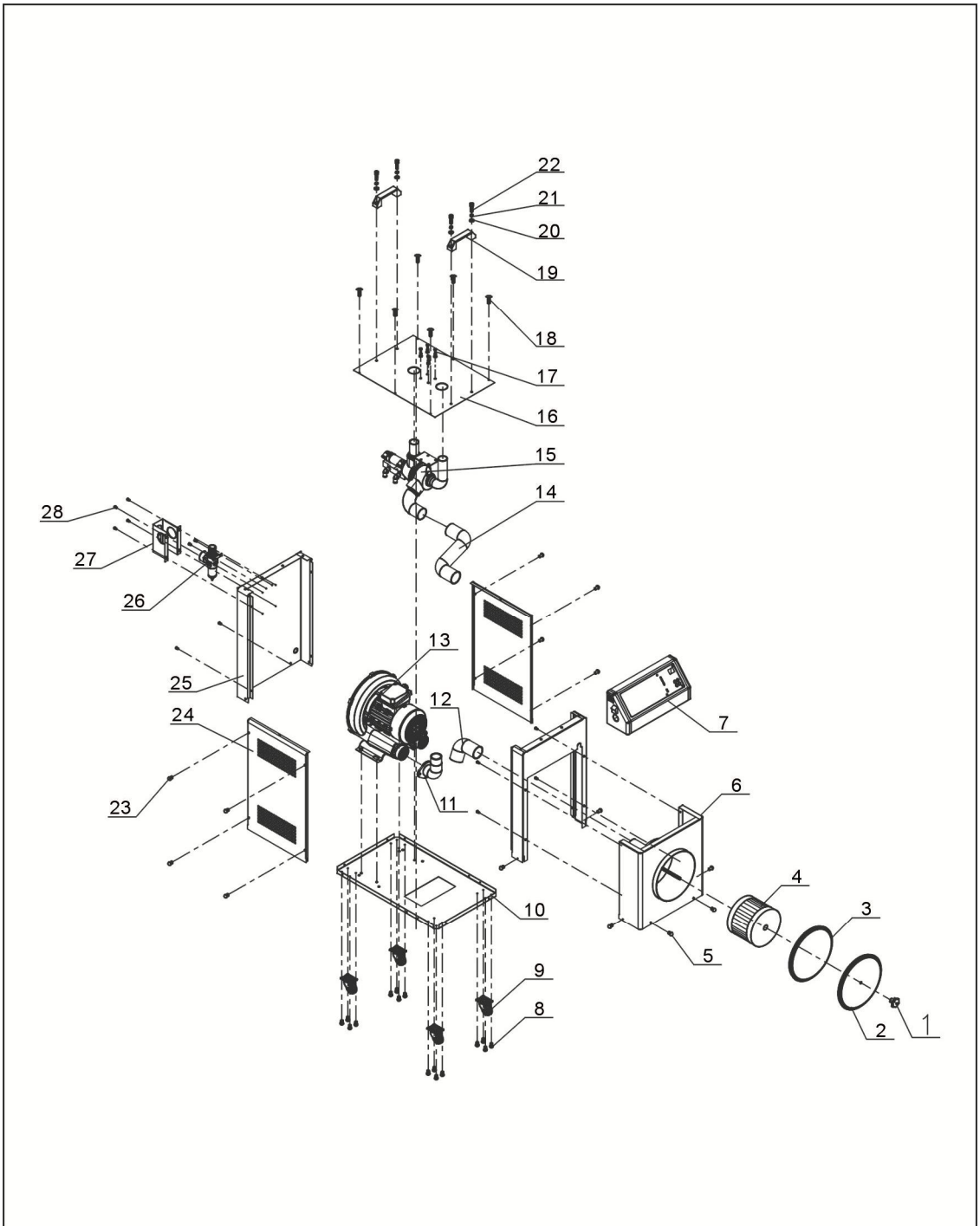

Remarks: Please refer to material list 6 for specific explanation of the Arabic numbers in parts drawing.

6. Parts List (SAL-900G/900G2)

No.	Name	Part No.
1	Star nut	YW09051600000
2	Filter barrel cover	-
3	Filter barrel fastener *	YR10080000300
4	Filter*	YR50708000100
5	Cross recessed pan head screw M6×10	YW62061000000
6	Front board	-
7	Control box	-
8	Cross recessed pan head screw M5×10	YW62051000100
9	Black castor 2"	YW03000200000
10	Base	-
11	Air inlet pipe elbow 1HP	YR40004700000
	Air inlet pipe elbow 2HP	YR40002000000
12	Steel wire hose 1	YR60000200000
13	High pressure bolwer 1HP	BM30031000150
	High pressure bolwer 2HP	BM30042000050
14	Steel wire hose 2	YR60000200000
15	Three way valve	-
16	Cover	-
17	Hexagon screw bolt M6×12	YW60061200100
18	Cross recessed pan head screw M6×10	YW62061000000
19	Aluminum square handle L120	BW20012000040
20	Flat washer	YW66061300000
21	Spring washer	YW65006000000
22	Inner hexagon column screw M6×20	YW61062000300
23	Cross recessed pan head screw M6×20	YW61062000300
24	Side plate	-
25	Rear plate	-
26	Filter & pressure regulating valve	YE30200020000
27	Filter & pressure regulating valve cover	-
28	Cross recessed pan head screw M5×10	YW62051000100

* means possible broken parts.

** means easy broken part. and spare backup is suggested.

Please confirm the version of manual before placing the purchase order to guarantee that the item number of the spare part is in accordance with the real object.

7. Vacuum Hopper Receiver Drawing (SMH-6L/12L)

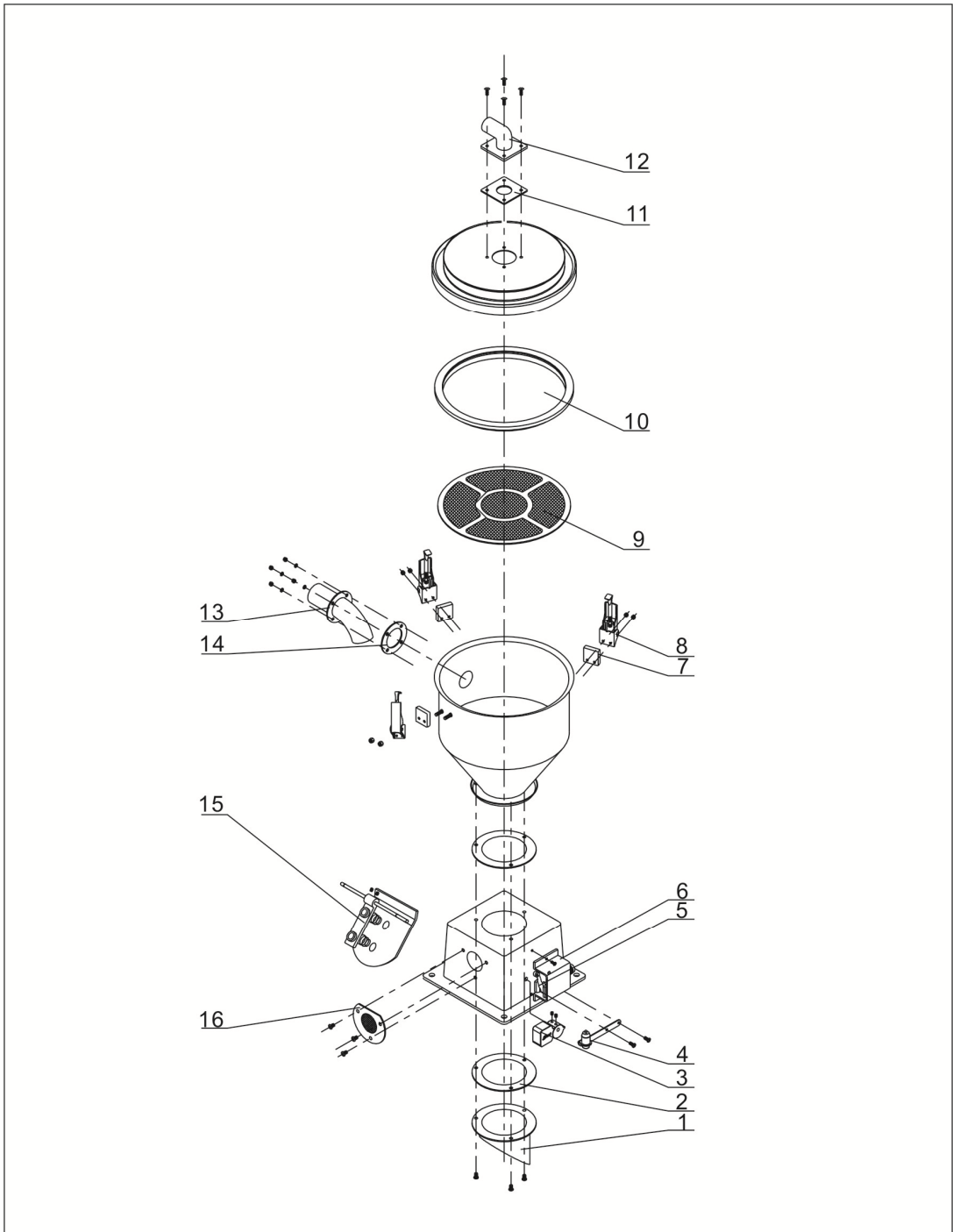

Remarks: Please refer to material list 8 for specific explanation of the Arabic numbers in parts drawing.

8. Vacuum Hopper Receiver Parts List (SMH-6L/12L)

No.	Name	Part No.	
		SMH-6L	SMH-12L
1	Grit hole	BL20333600020	BL20333600020
2	Base fastener *	YR10000000600	YR10000000600
3	Counter weight hammer	YW20602100000	YW20602100000
4	Structure of ejector pin	BH10000600050	BH10000600050
5	Micro switch *LXW5-11G2	YE14511200000	YE14511200000
6	Micro switch box	YR40330900000	YR40330900000
7	Snap hook block	YR40000600800	YR40000600800
8	Snap hook *	YW02003000400	YW02003000400
9	Filter screen *	BL21000600620	BL21001200320
10	Hopper fastener *	YR10000300100	YR10000600200
11	Fastener of air suction pipe *	YR10000000200	YR10000000200
12	Air suction pipe	BA20001500020	BA20001500020
13	Material inlet pipe *	BL32000600020	BL32000600020
14	Fastener of material inlet pipe *	YR10061200000	YR10061200000
15	Discharging plate assembly	BH90601200050	BH90601200050
16	Air vent window	YR40002400100	YR40002400100

* means possible broken parts.

** means easy broken part. and spare backup is suggested.

Please confirm the version of manual before placing the purchase order to guarantee that the item number of the spare part is in accordance with the real object.

9. Vacuum Hopper Receiver Drawing (SMH-24L)

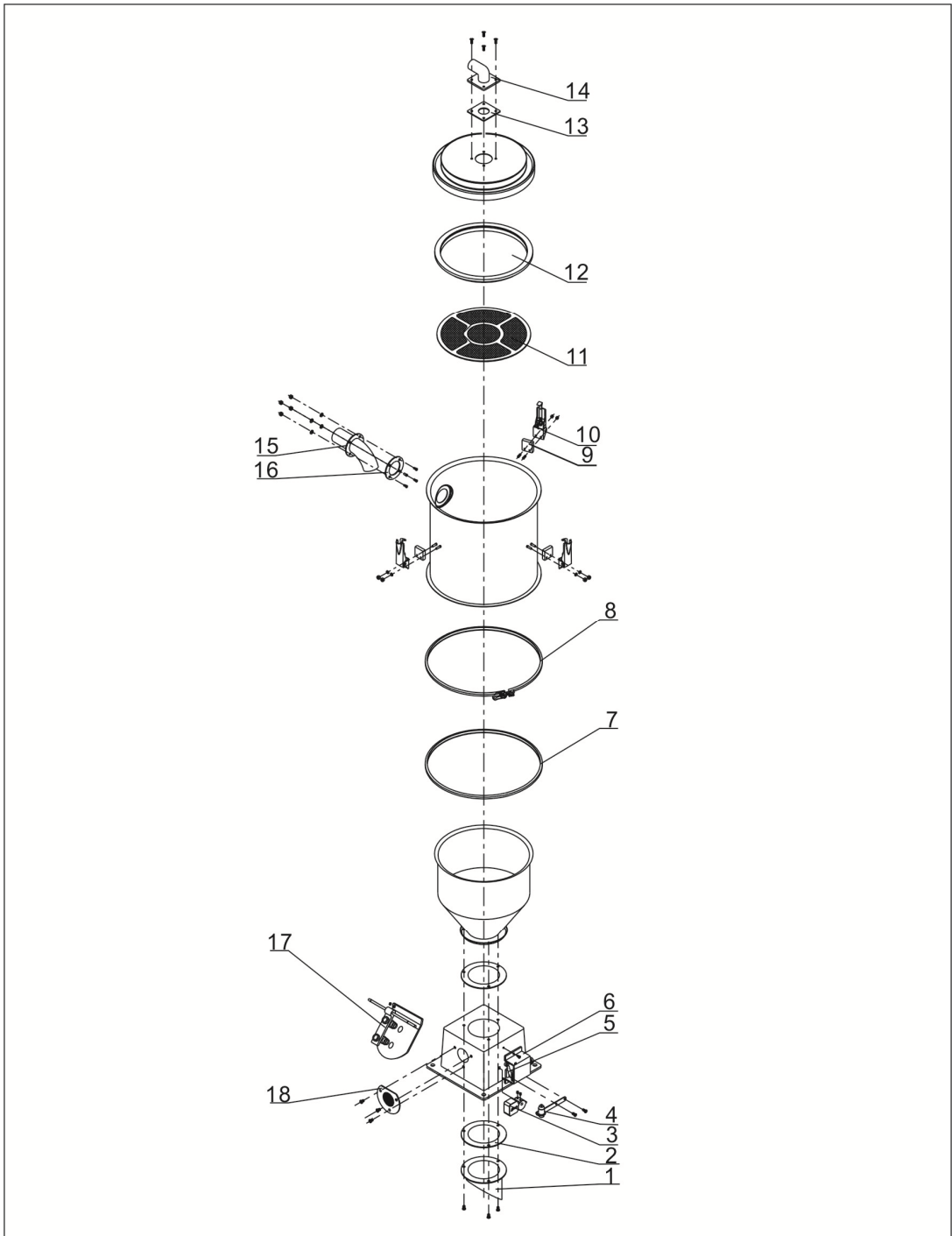

Remarks: Please refer to material list 10 for specific explanation of the Arabic numbers in parts drawing.

10. Vacuum Hopper Receiver Parts List (SMH-24L)

No.	Name	Part No.
1	Grit hole	BL2033600020
2	Base fastener *	YR10000000600
3	Counter weight hammer	YW20602100000
4	Structure of ejector pin	BH10000600050
5	Micro switch *LXW5-11G2	YE14511200000
6	Micro switch box	YR40330900000
7	Fastener of stainless steel clamp	YR10123640000
8	Stainless steel clamp	BH11120400010
9	Snap hook block	YR40000600800
10	Snap hook *	YW02003000400
11	Filter screen *	BL21001200320
12	Hopper fastener *	YR10000600200
13	Fastener of air suction pipe *	YR10000000200
14	Air suction pipe	-
15	Material inlet pipe *	BL27002401620
16	Fastener of material inlet pipe *	YR10243600000
17	Discharging plate assembly	BH90601200050
18	Air vent window	YR40002400100

* means possible broken parts.

** means easy broken part. and spare backup is suggested.

Please confirm the version of manual before placing the purchase order to guarantee that the item number of the spare part is in accordance with the real object.

11. Vacuum Hopper Receiver Drawing (SHR-6U/12U)

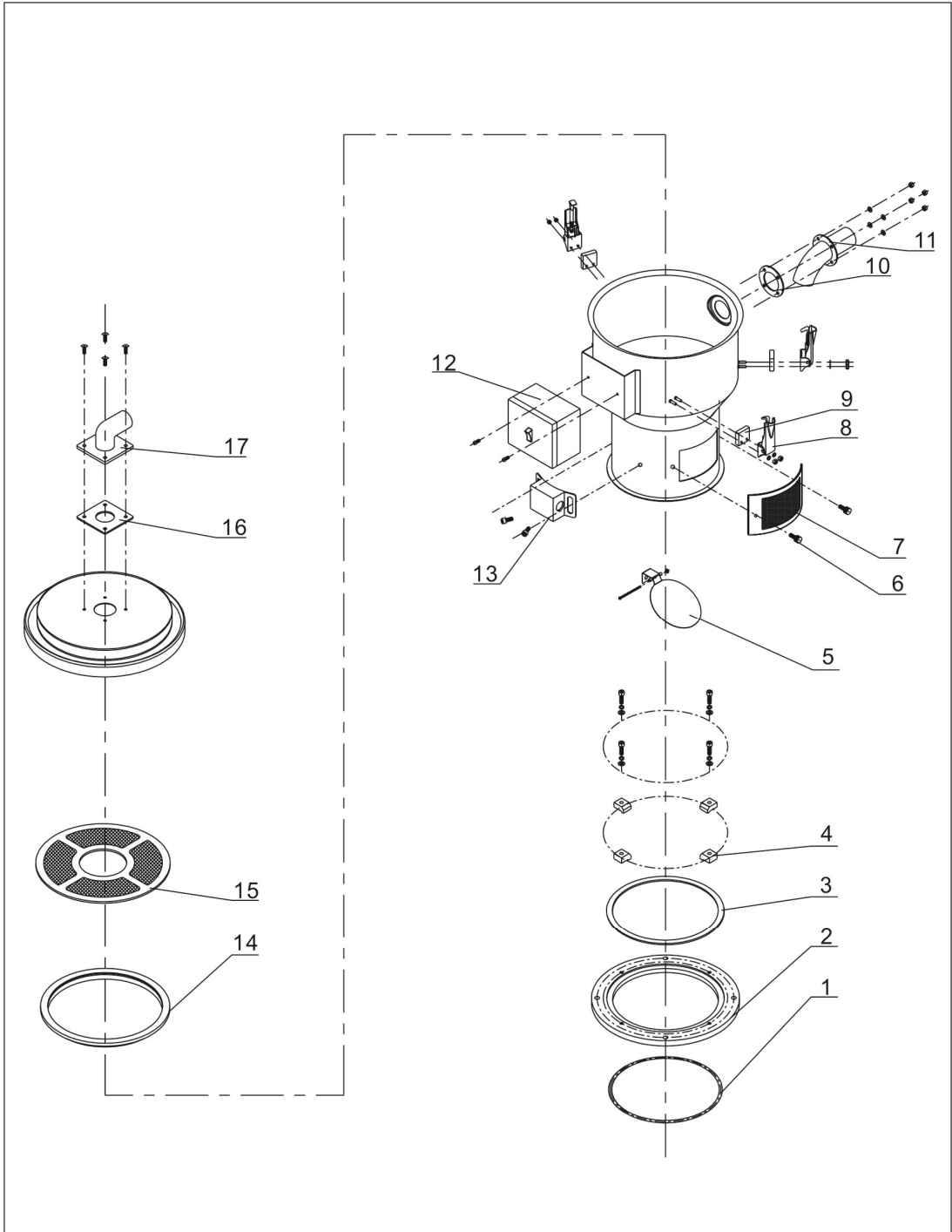

Remarks: Please refer to material list 12 for specific explanation of the Arabic numbers in parts drawing.

12. Vacuum Hopper Receiver Parts List (SHR-6U/12U)

No.	Name	Part No.	
		SHR-6U	SHR-12U
1	O-ring inner diameter	YR20205500000	YR20205500000
2	Base	BW21275100010	BW21275100010
3	Base fastener	-	-
4	Pressing piece	BW20000630500	BW20000630500
5	Discharging plate assembly	BL21001200920	BL21001200920
6	Star knob	YR40061500000	YR40061500000
7	Ventilation window	YR40000601000	YR40000601000
8	Snap hook block*	YR40000600800	YR40000600800
9	Snap hook *	YW02003000400	YW02003000400
10	Material inlet pipe *	YR10061200000	YR10061200000
11	Fastener of material inlet pipe *	BL32000600020	BL32000600020
12	Control box	YR40010000200	YR40010000200
13	Sensor shell	YR40000601100	YR40000601100
14	Hopper fastener *	YR10000300100	YR10000600200
15	Filter screen*	BL21000600620	BL21001200320
16	Fastener of air suction pipe *	YR10000000200	YR10000000200
17	Air suction pipe	BW20001500010	BW20001500010

* means possible broken parts.

** means easy broken part. and spare backup is suggested.

Please confirm the version of manual before placing the purchase order to guarantee that the item number of the spare part is in accordance with the real object.

13. Vacuum Hopper Receiver Drawing (SHR-24U)

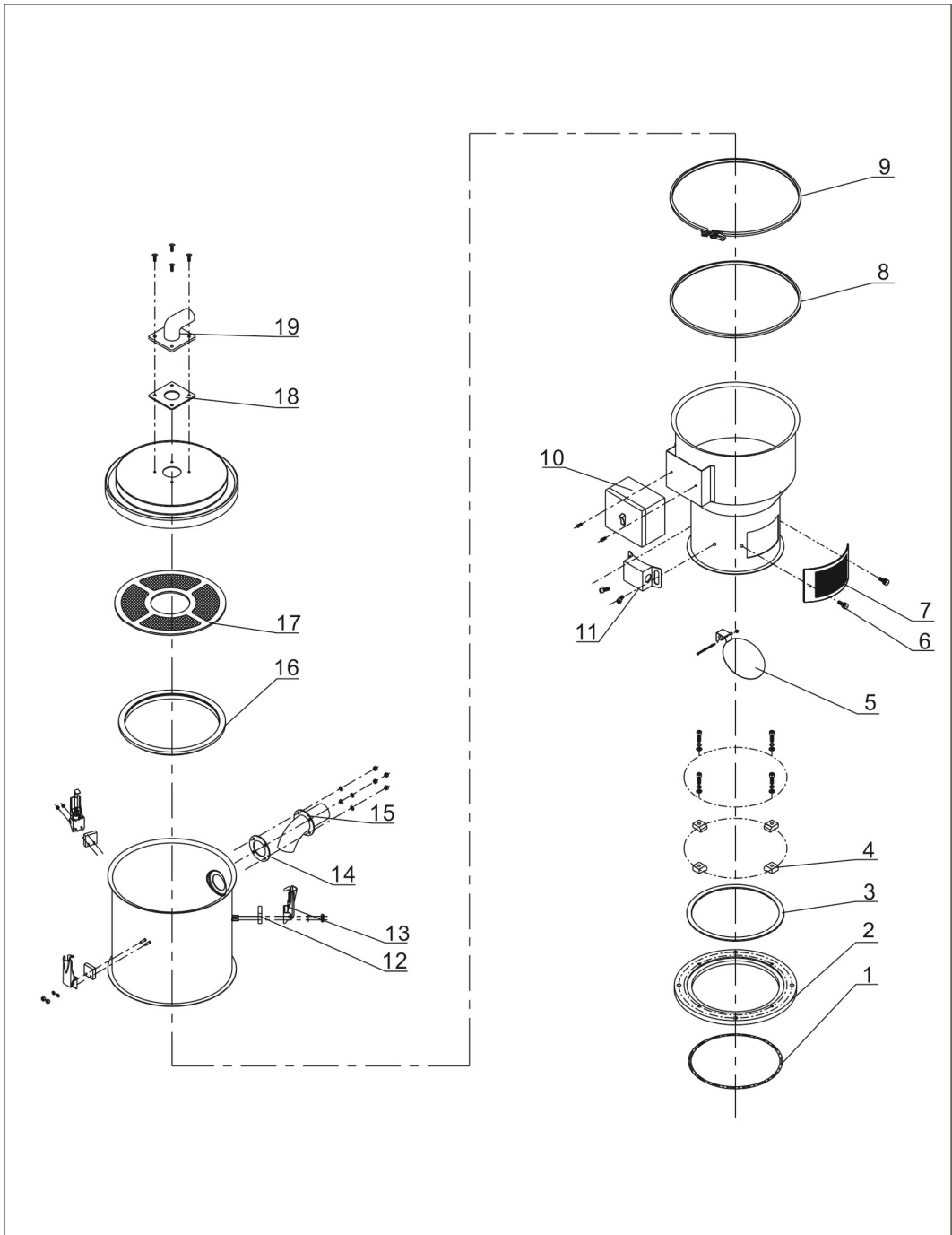

Remarks: Please refer to material list 14 for specific explanation of the Arabic numbers in parts drawing.

14. Vacuum Hopper Receiver Parts List (SHR-24U)

No.	Name	Part No.
1	O-ring inner diameter	YR20205500000
2	Base	BW21275100010
3	Base fastener	-
4	Pressing piece	BW20000630500
5	Discharging plate assembly	BL14052000410
6	Star knob	YR40061500000
7	Ventilation window	YR40000601000
8	Fastener of stainless steel clamp	YR10123640000
9	Stainless steel clamp	BH11120400010
10	Control box	YR40010000200
11	Sensor shell	YR40000601100
12	Snap hook block*	YR40000600800
13	Snap hook *	YW02003000400
14	Fastener of material inlet pipe *	YR10243600000
15	Material inlet pipe *	BL27002401620
16	Hopper fastener *	YR10000600200
17	Filter screen*	BL21001200320
18	Fastener of air suction pipe *	YR10002500000
19	Air suction pipe	-

* means possible broken parts.

** means easy broken part. and spare backup is suggested.

Please confirm the version of manual before placing the purchase order to guarantee that the item number of the spare part is in accordance with the real object.

15. Photosensor Hopper Receiver Drawing (SVH-6L)

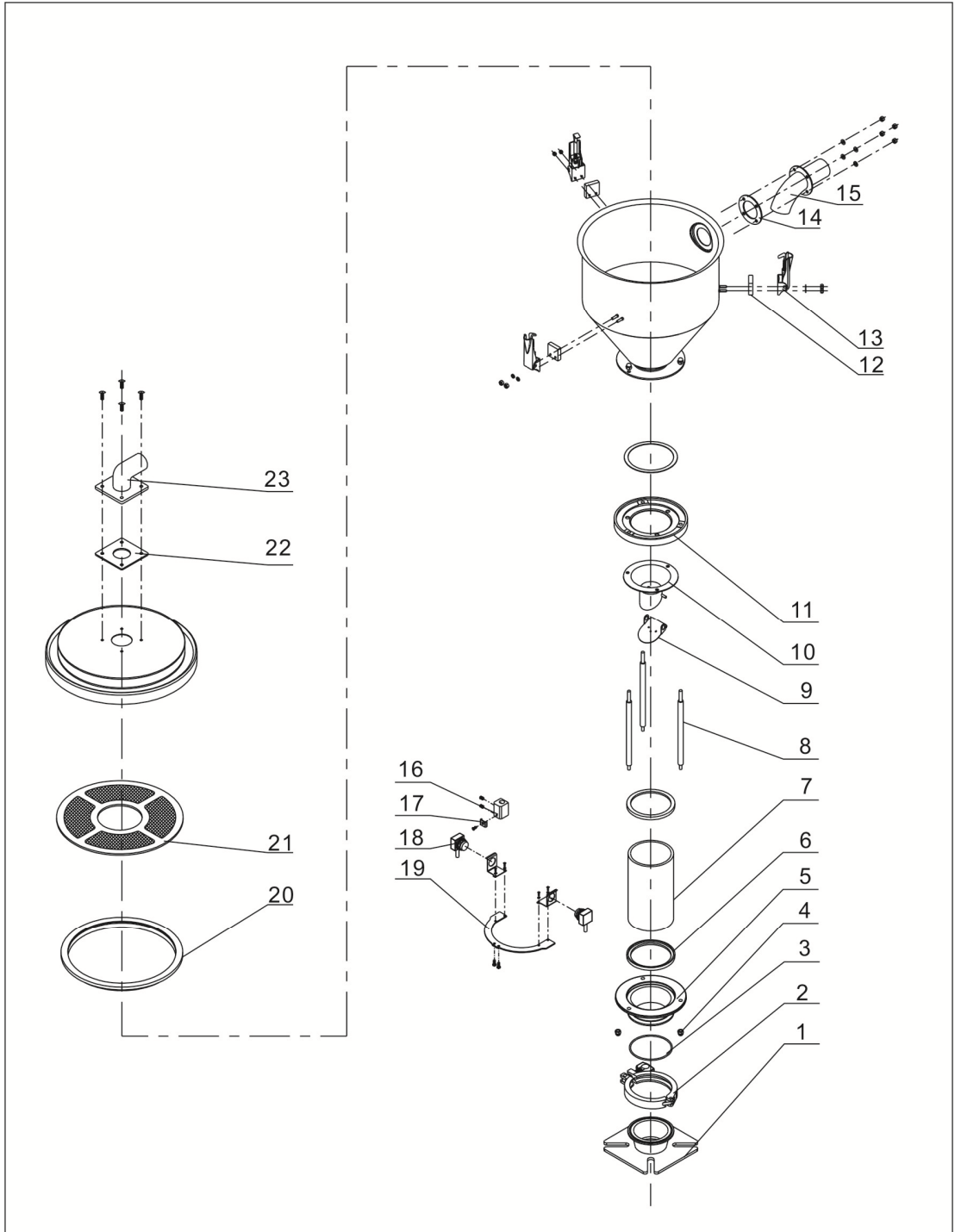

Remarks: Please refer to material list 16 for specific explanation of the Arabic numbers in parts drawing.

16. Photosensor Hopper Receiver Parts List (SVH-6L)

No.	Name	Part No.
1	Installation flange	BL21060200820
2	3" stainless steel pipe clamp	YW07000300000
3	O type seal ring	YR20802600000
4	Cap nut M6	YW64006000100
5	Lower flange of glass tube	BW32610900010
6	Glass tube fastener	YR10060200000
7	Glass tube	YW70317000600
8	Flange connecting rod	BH10000600640
9	Non-return valve	BL21000605320
10	Discharging port	BW32060300610
11	Upper flange of glass tube	BW32610800010
12	Snap hook block*	YR40000600800
13	Snap hook *	YW02003000400
14	Fastener of material inlet pipe *	YR10061200000
15	Material inlet pipe *	BL32000600020
16	Fixed plate of photosensor	BL90001000120
17	Pressing piece of photosensor wire	YW31616200000
18	Photoelectric switch	YE15143900000
19	Photosensor stator	BL21061200020
20	Hopper fastener *	YR10000300100
21	Filter screen*	BL21000600620
22	Fastener of air suction pipe *	YR10000000200
23	Air suction pipe	YR20001500000

* means possible broken parts.

** means easy broken part. and spare backup is suggested.

Please confirm the version of manual before placing the purchase order to guarantee that the item number of the spare part is in accordance with the real object.

17. Photosensor Hopper Receiver Drawing (SVH-12L)

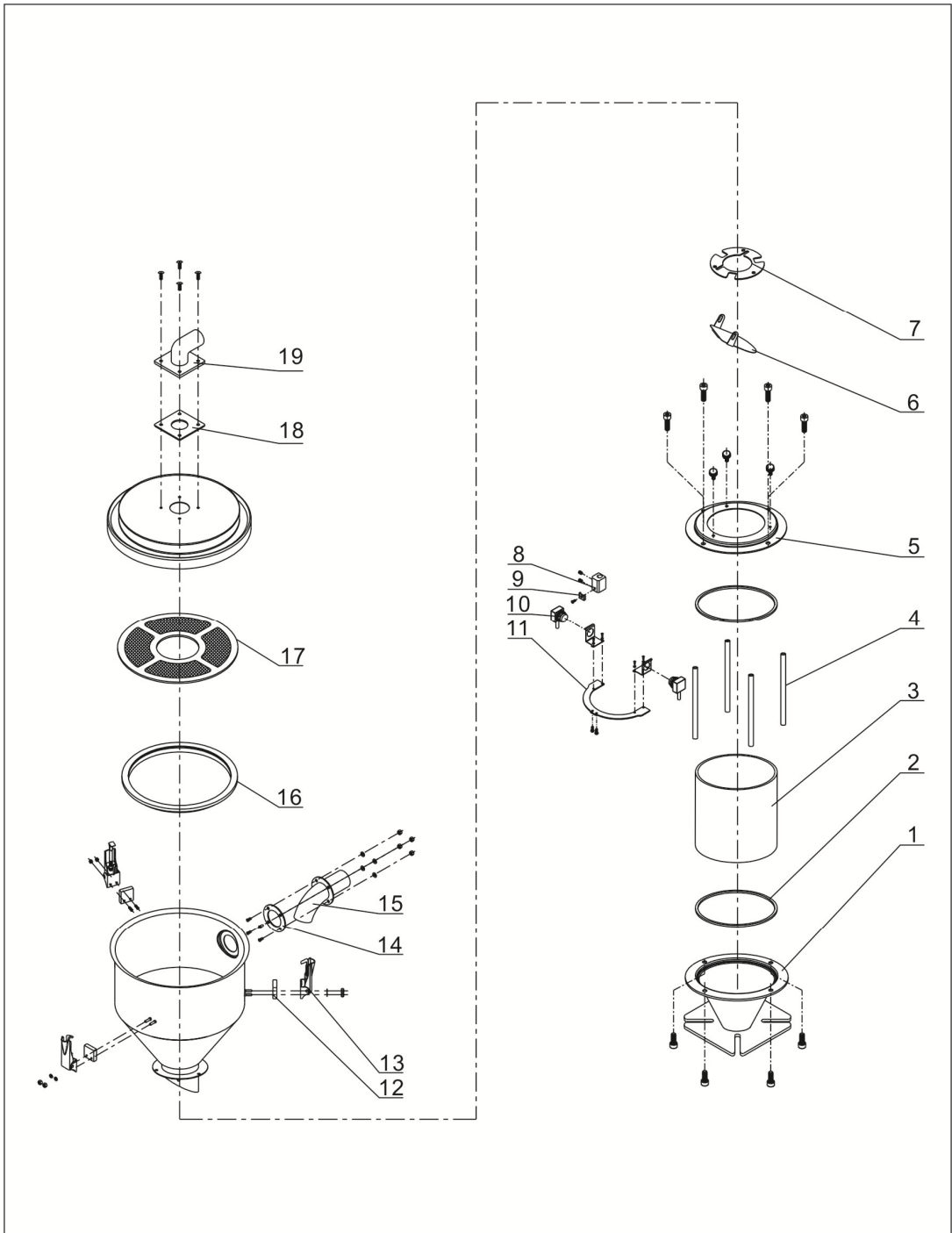

Remarks: Please refer to material list 18 for specific explanation of the Arabic numbers in parts drawing.

18. Photosensor Hopper Receiver Parts List (SVH-12L)

No.	Name	Part No.
1	Lower flange of glass tube	YW32001200000
2	Glass tube fastener	YR10001200100
3	Glass tube	YW70171700000
4	Flange connecting rod	BH10101600210
5	Upper flange of glass tube	YR32001200100
6	Non-return valve*	BL21001200520
7	Vent flange	-
8	Fixed plate of photosensor	BL90001000120
9	Pressing piece of photosensor wire	YW31616200000
10	Photoelectric switch	YE15143900000
11	Photosensor stator	BL21001200120
12	Snap hook block*	YR40000600800
13	Snap adjustable	YW02003000400
14	Fastener of material inlet pipe *	YR10061200000
15	Material inlet pipe *	BL32000600020
16	Hopper fastener *	YR10000600200
17	Filter screen*	BL21001200320
18	Fastener of air suction pipe *	YR10000000200
19	Air suction pipe	BW20001500010

* means possible broken parts.

** means easy broken part. and spare backup is suggested.

Please confirm the version of manual before placing the purchase order to guarantee that the item number of the spare part is in accordance with the real object.

19. Photosensor Hopper Receiver Drawing (SVH-24L)

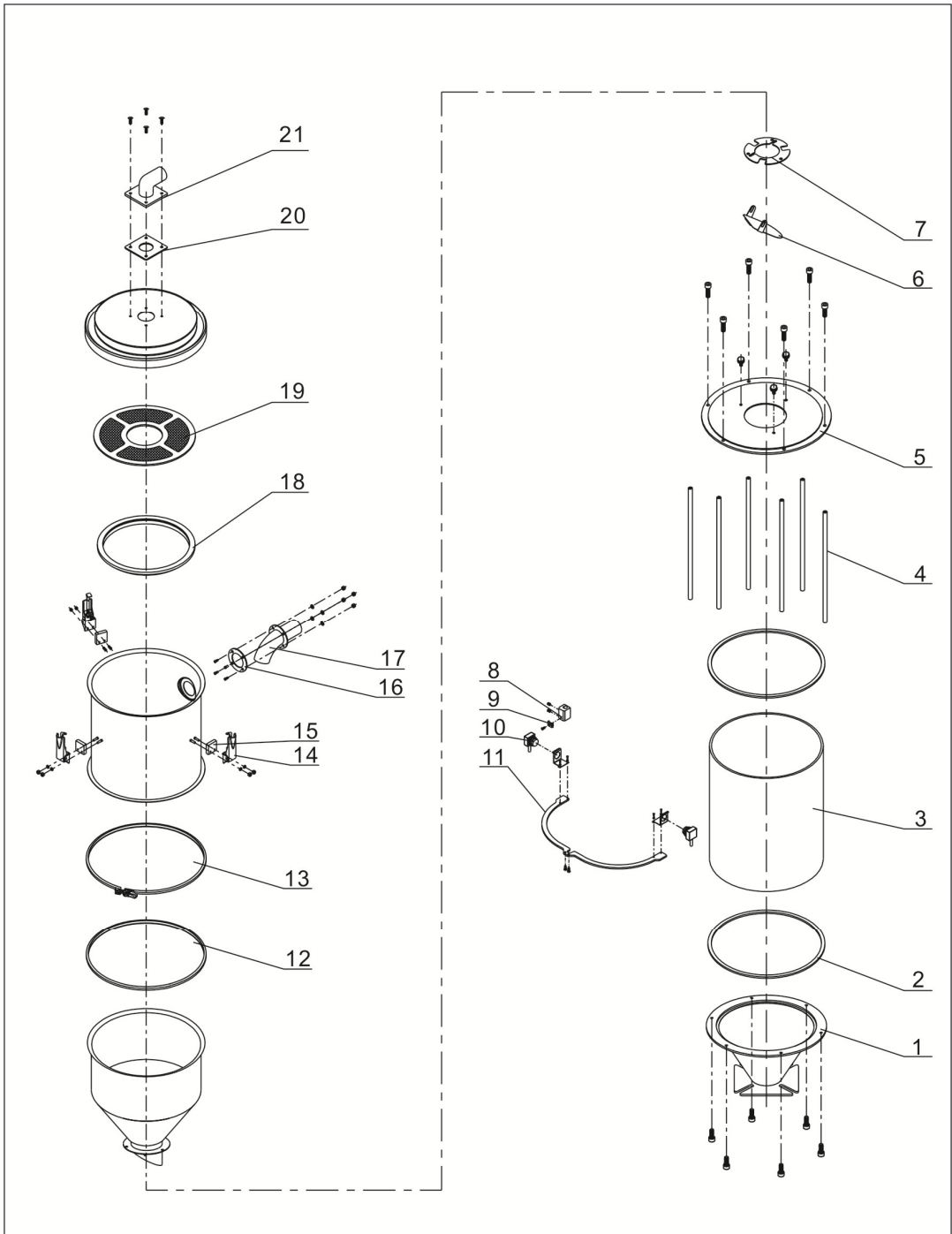

Remarks: Please refer to material list 20 for specific explanation of the Arabic numbers in parts drawing.

20. Photosensor Hopper Receiver Parts List (SVH-24L)

No.	Name	Part No.
1	Lower flange of glass tube	-
2	Glass tube fastener	YR10001200100
3	Glass tube	YW70282700000
4	Flange connecting rod	BH10103300040
5	Upper flange of glass tube	-
6	Non-return valve*	BL21001200520
7	Vent flange	-
8	Fixed plate of photosensor	BL90001000120
9	Pressing piece of photosensor wire	YW31616200000
10	Photoelectric switch	YE15143900000
11	Photosensor stator	-
12	Fastener of stainless steel clamp	YR10123640000
13	Stainless steel clamp	BH11120400010
14	Snap hook block*	YW02003000400
15	Snap adjustable	YR40000600800
16	Fastener of material inlet pipe *	BL27002401620
17	Material inlet pipe *	YR10243600000
18	Hopper fastener *	YR10000600200
19	Filter screen*	BL21001200320
20	Fastener of air suction pipe *	YR10002500000
21	Air suction pipe	-

* means possible broken parts.

** means easy broken part. and spare backup is suggested.

Please confirm the version of manual before placing the purchase order to guarantee that the item number of the spare part is in accordance with the real object.