

					制图	版号	0	标题	SG-90160	图号	比例	第 2 张
					设计	核	准	主电路图二	SG-90160-400V-TZ-9947-CE-0-2	标准	CE	共 8 张
					校对	日期					2024.03.20	机器电压
标记	更改前	更改后	更改人	日期	审核	日期	2024.03.20	 信易電熱機械股份有限公司 Shini Plastics Technologies, Inc.		机器频率	50Hz	

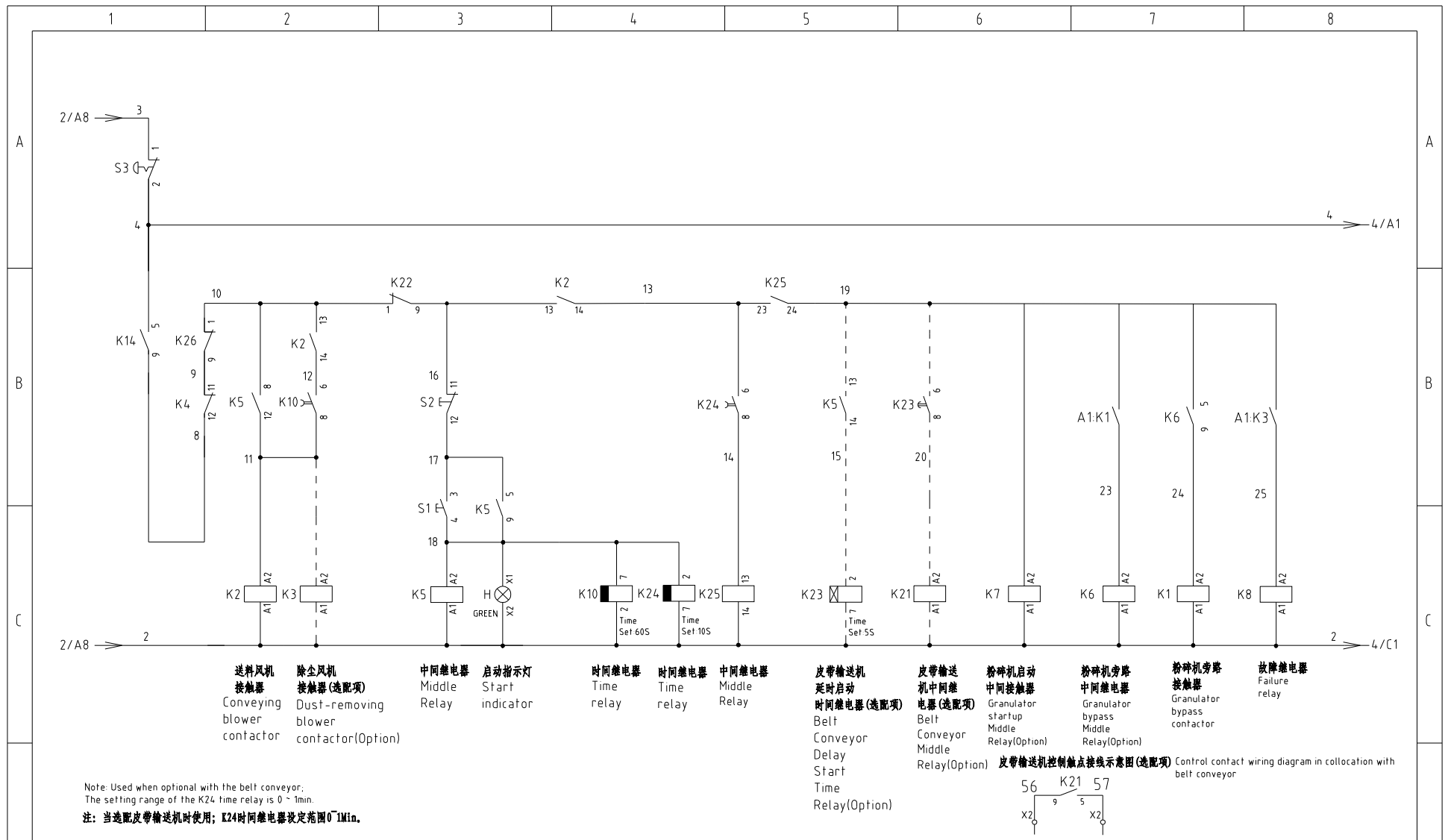

Note: Used when optional with the belt conveyor;
 The setting range of the K24 time relay is 0 ~ 1min.
 注: 当选配皮带输送机时使用; K24时间继电器设定范围0~1Min.

皮带输送机控制触点接线示意图(选配项) Control contact wiring diagram in collocation with belt conveyor

					制图	版号	0	标题	SG-90160	图号	SG-90160-400V-TZ-9947-CE-0-3	比例	第 3 张
					设计	核准		控制电路图一				标准	CE
					校对	日期	20240320	信易电热机械股份有限公司 Shini Plastics Technologies, Inc.	机器电压	3φ400V			
标记	更改前	更改后	更改人	日期	审核		机器频率		50Hz				

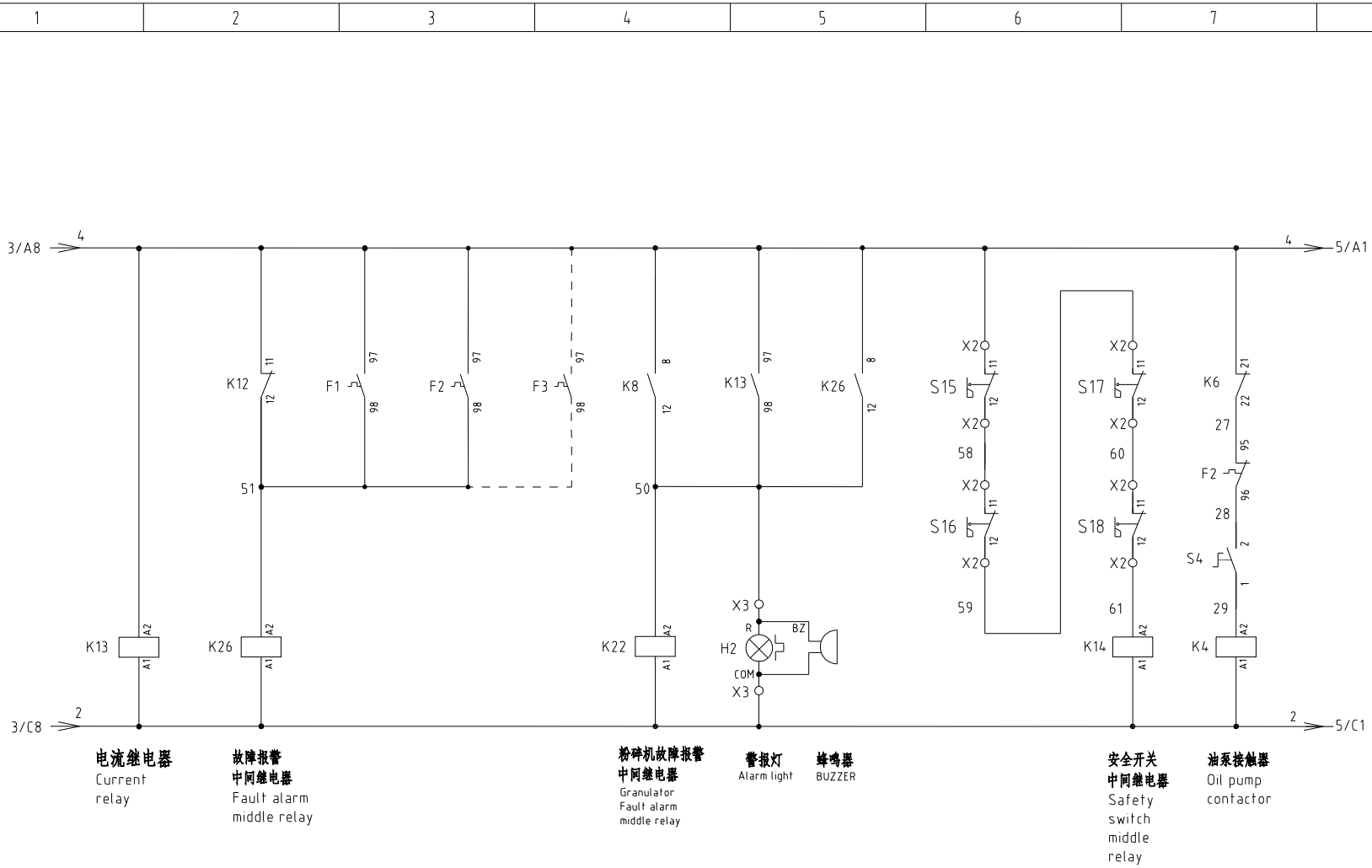

电流继电器
Current relay

故障报警
中间继电器
Fault alarm middle relay

粉碎机故障报警
中间继电器
Granulator Fault alarm middle relay

警报灯 蜂鸣器
Alarm light BUZZER

安全开关
中间继电器
Safety switch middle relay

油泵接触器
Oil pump contactor

					制图	版号	0	标题	SG-90160	图号	比例	第 4 张
					设计	核准		控制电路图二	SG-90160-400V-TZ-9947-CE-0-4		标准	共 8 张
					校对			 信易電熱機械股份有限公司 Shini Plastics Technologies, Inc.	机器电压	3φ400V		
标记	更改前	更改后	更改人	日期	审核	日期	2024.03.20		机器频率	50Hz		

1 2 3 4 5 6 7 8

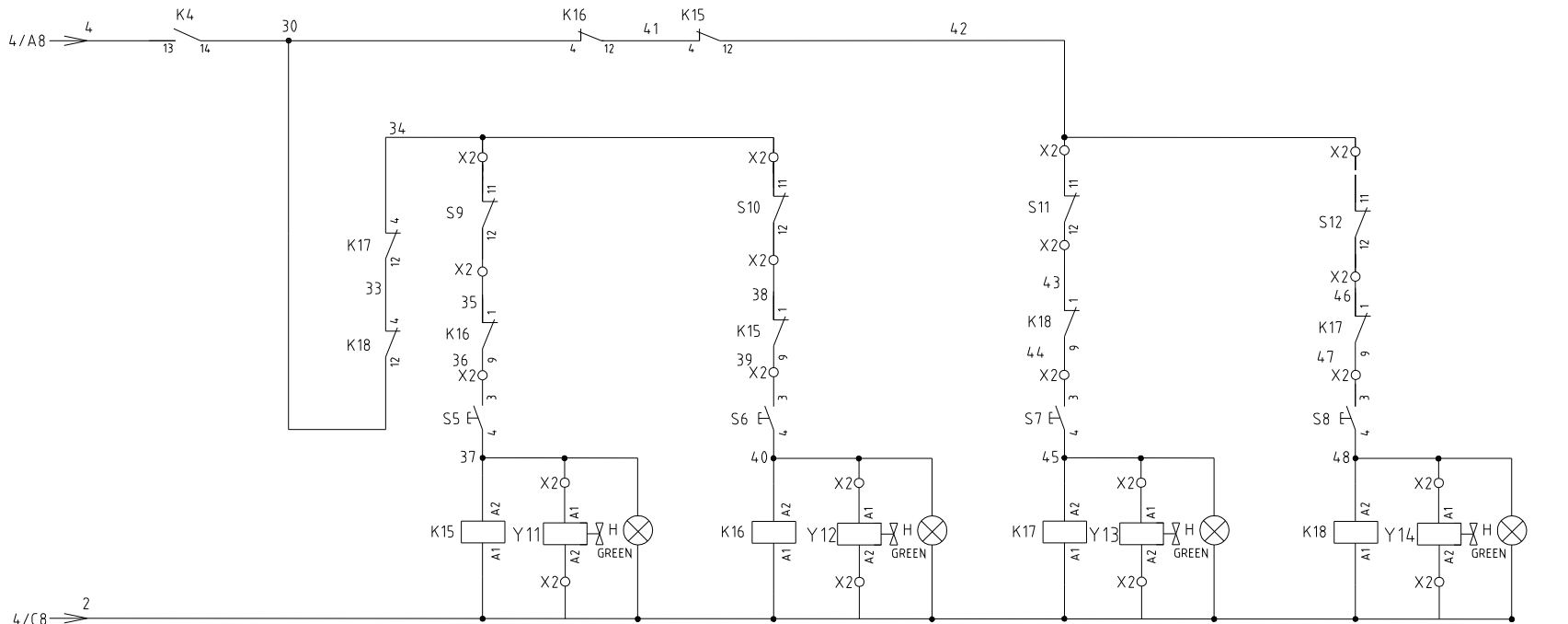

进料箱上升 中间继电器 Feeding box rise-up middle relay	电磁阀 1/1 Solenoid valve 1/1	进料箱上升 指示灯 Feeding box rise-up indicator	进料箱下降 中间继电器 Feeding box go-down middle relay	电磁阀 1/2 Solenoid valve 1/2	进料箱下降 指示灯 Feeding box go-down indicator	筛网架上升 中间继电器 Screen frame rise-up middle relay	电磁阀 2/1 Solenoid valve 2/1	筛网架上升 指示灯 Screen frame rise-up indicator	筛网架下降 中间继电器 Screen bracket go-down middle relay	电磁阀 2/2 Solenoid valve 2/2	筛网架下降 指示灯 Screen bracket go-down indicator
--	----------------------------------	--	--	----------------------------------	--	---	----------------------------------	---	---	----------------------------------	---

					制图	版号	0	标题	SG-90160	图号	SG-90160-400V-TZ-9947-CE-0-5	比例	第 5 张
					设计	核准		控制电路图三		标准	CE	共 8 张	
					校对	日期	20240320	 信易电热机械股份有限公司 Shini Plastics Technologies, Inc.		机器电压	3φ400V		
标记	更改前	更改后	更改人	日期	审核	日期	20240320			机器频率	50Hz		

1		2		3		4		5		6		7		8	
序号/NO	符号/Symbol	名称/Name		制造商/Manufacturer		型号/Type		规格/Specification		数量/Number		物料编号/Material number		备注/Remark	
1	Q1	门连锁断路器/Break Interlock		ABB		A3N400TMF320/32003PFF		320A		1		YE41503400000			
2	Q2	断路器/Circuit breaker		TECO		BM-100D/3063S		100A		1		YE40301003000			
3	Q3	断路器/Circuit breaker		TECO		BM-63C/3P		10A		1		YE40301003000		(2)	
4	Q4	断路器/Circuit breaker		TECO		BM-63C/3P		16A		1		YE40301603000			
5	A1	软启动器/Soft Starter		CHNT		NJR2-185D		400VAC		1		YM50218500000			
6	K1	接触器/Contactor		CHNT		CJ40-400		220VAC 50/60Hz		1		YE00405000000			
7	K2	接触器/Contactor		SIEMENS		3RT6025-1AN20		220V 50/60Hz		1		YE00602522000			
8		辅助触点/Auxiliary contactor		SIEMENS		3RH6911-1AA10		220V 50/60Hz		1		YE00691110000			
9	K3	接触器/Contactor		SIEMENS		3RT6015-1AN22		220V 50/60Hz		1		YE00601522000		(2)	
10	K4	接触器/Contactor		SIEMENS		3RT6015-1AN22		220V 50/60Hz		1		YE00601522000			
11	K6	接触器/Contactor		SIEMENS		3RT6025-1AN20		220V 50/60Hz		1		YE00602522000			
12	K13	电流继电器/Current relay		SCHNEIDER		LT4706M7A		220VAC 0.5-6A		1		YE04470600600			
13	K23	时间继电器/Time relay		YUYUN		TH3M-NAB		220VAC 3~60S		1		YE86300300000		(3)	
14	K10 K24	时间继电器/Time relay		YUYUN		TRF-N		220VAC 3M		2		YE86322000000			
15	K12	相序保护器/Phase sequence protector		CHAOSHI		ABJ-10W		400V 50/60Hz		1		YE03103800000			
16	K7 K8 K14~K18	中间继电器/Middle relay		WEIDMULLER		DRM270730LT		220VAC		7		YE03270700000			
17	K5	中间继电器/Middle relay		WEIDMULLER		DRM570730LT		220VAC		1		YE03570700000			
18	K21,K22 K25 K26	中间继电器/Middle relay		WEIDMULLER		DRM270730LT		220VAC		4		YE03270700000			
19	F2	热过载继电器/Overload relay		SIEMENS		3RU6126-4DB0		20-25A		1		YE01260200000			
20	F3	热过载继电器/Overload relay		SIEMENS		3RU6116-1EB0		2.8-4A		1		YE01160280000		(2)	
21	TA1,TA2	电流互感器/Current transformer		CHNT		BH-0.66		600/5A		2		YE04666000000			
22	H2	警报灯/Alarm lamp		SHINI		SWI-R-AC115V/230V		220VAC		1		BL90011500020			
23	S1, S5~S8(H)	启动按钮(带灯)/Start button(with light)		SCHNEIDER		XB2BW33M1C		400VAC		5		YE11223100000			
24	S2	停止按钮/Stop button		SCHNEIDER		XB2BA22C		400VAC		1		YE11222000000			
25	S3	急停按钮/Emergency stop button		SCHNEIDER		XB2BS542C		400VAC		1		YE11254200000			
注: (1)表示非电控箱内材料; (2)表示除尘马达选配件; (3)表示皮带输送机选配件; Notes: (1)Means it 's not the material inside the control box. (2)Means optional accessories of dedusting motor. (3)Belt conveyor accessories.															
D				制图		版号		0		标题		SG-90160		图号	
				设计		核				电气元件明细表一		SG-90160-400V-TZ-9947-		比例	
				校对		准						CE-0-7		CE	
标记		更改前		更改后		更改人		日期		20240320		SHINI 信易電熱機械股份有限公司 Shini Plastics Technologies, Inc.		第 7 张	
1		2		3		4		5		6		7		8	
												机器电压		400V	
												机器频率		50Hz	

1	2	3	4	5	6	7	8	
序号/NO	符号/Symbol	名称/Name	制造商/Manufacturer	型号/Type	规格/Specification	数量/Number	物料编号/Material number	备注/Remark
26	S4	选择开关/Selector Switches	ABB	C2SS2-10B-10	Ui=300V Ith=5A	1	YE12210100000	
27	S9,S10,S11,S12	行程开关/ Position limit switch	SCHMERSAL	TS236-11Z-M20	500V	4	YE10361200000	(1)
28	S13	安全开关/Safety switch	SCHMERSAL	AZ17-11ZK	AZ-17	1	YE16171100000	(1)
29	S14,S15	电感式传感器/Electric sensor	DELIN	DL-12	24VDC	2	YE15122400000	(1)
30	X1 X2 X3	端子排/Terminal board	--	DKB60	65A	4	YE60100006900	
31			Honeywell	SK2 5	2.5mm ²	44	YE60002503200	
32			Honeywell	SK2.5PE	2.5mm ² PE	6	YE61002500500	
33	Y11 Y12 Y13 Y14	电磁阀/Solenoid Valve	----	----	230V 50Hz	2	-----	(1)
34	M1	马达/Motor	--	200KW	400V 50Hz	1	-----	(1)
35	M2	油泵马达/Oil pump motor	--	22KW	400V 50Hz	1	-----	(1)
36	M3	风机/Blower	--	0.75KW	400V 50Hz	1	-----	(1)
37	M4	风机/Blower	--	1.5KW	400V 50Hz	1	-----	(1)
38	S0	行程开关/ Position limit switch	---	YBLXW-5/11G2	230VAC	1	YE14.511200000	(1)
39	H1	照明灯/Floodlight	NVC	4W	230VAC	1	YF80030400000	(1)
40								
41								
42								
43								
44								
45								
46								
47								
48								
49								
50								

注: (1)表示非电控箱内材料 Notes: (1)Means it 's not the material inside the control box

制图		版号		0		标题		SG-90160		图号		比例		第 8 张	
设计		核		准		电气元件明细表二		SG-90160-400V-TZ-9947-		标准		CE		共 8 张	
校对		日期		2024.03.20		 信易電熱機械股份有限公司 Shini Plastics Technologies, Inc.		机器电压		400V		机器频率		50Hz	
标记		更改前		更改后				更改人		日期					
1		2		3		4		5		6		7		8	