

CBD Series
Up-feed Belt Conveyor
With Separators

Date: May 2020

Version: Ver.C (English)



Contents

1. General Description	5
1.1 Coding Principle.....	6
1.2 Features.....	6
1.3 Technical Specifications	8
1.4 Safety Regulations.....	9
1.4.1 Safety Signs and Labels.....	9
1.5 Exemption Clause.....	11
2. Structural Features and Working Principle.....	12
2.1 Function Description	12
2.1.1 Working Principle.....	12
3. Installation Testing.....	14
3.1 Attention.....	14
3.2 Horizontal Installation.....	14
3.3 Power Connections.....	15
4. Operation	16
4.1 Start / Stop the Machine	16
4.2 Adjustment of the Height of the Conveyor	16
4.3 Adjusting the Central Space of the PU Belt	17
4.4 Regulation of Sidewall	18
5. Trouble-shooting.....	19
6. Service and Maintenance	20
6.1 Repair	20
6.2 Maintenance	20
6.2.1 Maintenance of the Gear Motor.....	20
6.2.2 Clearance of the Machine.....	21
6.2.3 Lubricate the Bearing	22
6.3 Maintenance Schedule	23
6.3.1 About the Machine.....	23
6.3.2 Check After Installation.....	23

6.3.3	Daily Checking	23
6.3.4	Weekly Checking.....	23
6.3.5	Monthly Checking.....	23
7.	Assembly Drawing	24
7.1	Spare Parts Drawing.....	24
7.2	Spare Parts List	25
7.3	Base Parts Drawing	26
7.4	Base Parts List.....	27
7.5	Spare Parts Drawing.....	28
7.6	Parts List.....	29
8.	Electrical Circuit Diagram.....	35

Form index

Table 1-1:	Dimensions List	8
------------	-----------------------	---

Table index

Picture 1-1:	Dimensions.....	8
Picture 2-1:	Working Principle.....	12
Picture 3-1:	Installation Drawing	14
Picture 3-2:	Power Connections	15
Picture 3-3:	Machine Installation Drawing.....	15
Picture 4-1:	Conveyor Belt Adjusting Drawing	16
Picture 4-2:	PU Adjusting Drawing.....	17
Picture 4-3:	Regulation of Sidewall	18
Picture 6-1:	Gear motor	21
Picture 6-2:	Bearing Lubricate Drawing	22

1. General Description



Please read this manual carefully before using this machine in order to operate correctly against any damage caused due to improper operation.



Forbidden to process flammable or toxic material!

Shini manufactures five model of belt conveyor as follows under technical license from a leading european manufacturer:

CBD series conveyor feature reliable performance and ease of operation and are suitable for conveying finished products to separator to separate product from its connecting sprues. The height is adjustable.



Model: CBD-12

1.1 Coding Principle

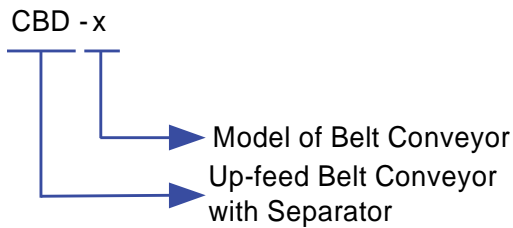

1.2 Features

- Mounted on patented "FUTURE" floor stand.
- PVC belt is adopted for smooth and efficient conveying.
- Fixed speed of 4m/min.
- Height adjustable floor stand.
- Sidewalls for CBD series 95 mm respectively.
- Maximum loading capacity of CB is 56kg,
- Power supply CBD series are 1Φ, 230VAC, 50Hz.
- Standard with frequency converter, the normal application and safety speed control of the conveyor are within 3~6m/min.

All service work should be carried out by a person with technical training or corresponding professional experience. The manual contains instructions for both handling and servicing. Chapter 7, which contains service instructions intended for service engineers. Other chapters contain instructions for the daily operator. Any modifications of the machine must be approved by SHINI in order to avoid personal injury and damage to machine. We shall not be liable for any damage caused by unauthorized change of the machine.

Our company provides excellent after-sales service. Should you have any problem during using the machine, please contact the company or the local vendor.

Headquarter and Taipei factory:

Tel: (886) 2 2680 9119

Shini Plastics Technologies (Dongguan), Inc:

Tel: (86) 769 8111 6600

Shini Plastics Technologies India Pvt.Ltd.:

Tel: (91) 250 3021 166

1.3 Technical Specifications

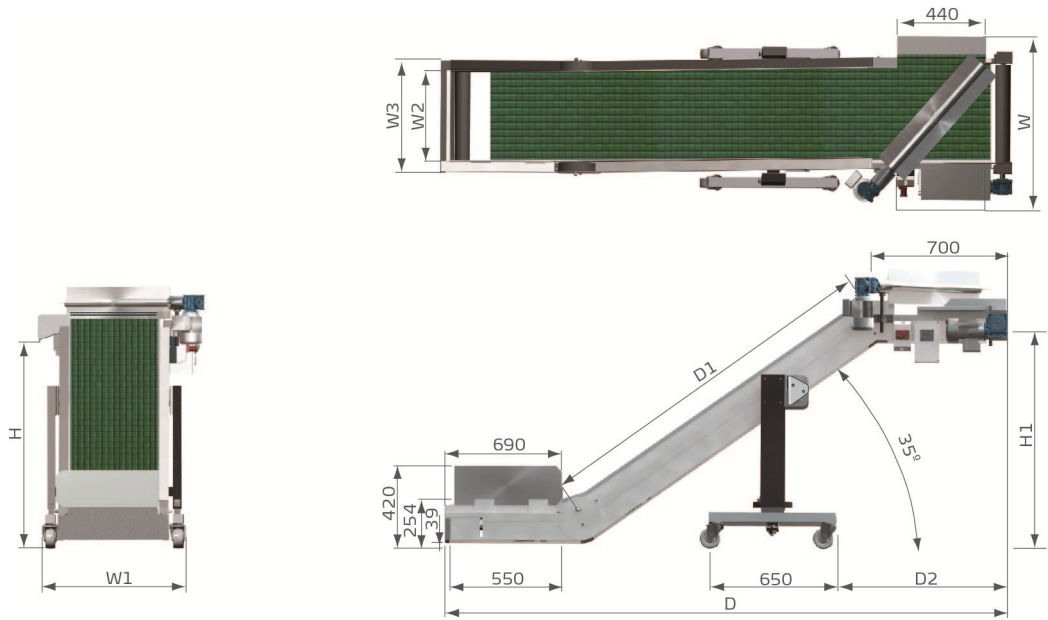

Picture 1-1: Dimensions

Table 1-1: Dimensions List

Model	CBD-7	CBD-8	CBD-9	CBD-10	CBD-11	CBD-12
Ver.	C	C	C	C	C	C
H (mm)	855+70	855+70	855+70	1140+140	1140+140	1140+140
H1 (mm)	797+70	797+70	797+70	1083+140	1083+140	1083+140
W (mm)	650	730	880	650	730	880
W1 (mm)	506	576	706	506	576	706
W2 (mm)	250	320	450	250	320	450
W3 (mm)	358	428	558	358	428	558
D (mm)	2455	2455	2455	2865	2865	2865
D1 (mm)	1300	1300	1300	1800	1800	1800
D2 (mm)	747	747	747	870	870	870
Weight (kg)	130	140	155	135	150	169

1.4 Safety Regulations

To avoid any body injures and damages of the machine, please obey the regulations in this manual. When operating this machine, please obey the regulations as follows.

1.4.1 Safety Signs and Labels



Electrical installation should be done by qualified electricians. Turn off the main switch and control switch before servicing and maintenance.



Warning!

The sound level produced by the machine is < 70dB (max) at the position of the operator.



Notice:

Noise level test refers to the following conditions: 1m around the machine, 1.6m above the machine.



Warning!

- 1) Don't use the machine and don't try to repair it before carefully read this manual and understood all its parts completely.
- 2) In particular, it is important to adopt the precaution listed in section a 'safety instruction'.
- 3) It is forbidden to use the machine in any condition or for any use different from what is indicated in the manual. SHINI has no responsibility for breakdowns, trouble, or injuries caused by improper operation.



Attention!

No need for regular inspection because all the electrical parts in the control unit are fixed tightly!



Attention!

The maximum weight of the pieces to be carried on the conveyor belt must not be over 56kg in total.

The conveyor belts are not suitable to transport loose material.



Attention!

These conveyor belts can be easily used by all of the personnel of the plant they are installed in, and they do not present any risk for the operator, if used properly.

Therefore, it is recommended to read the manual carefully before using the machine.



Attention!

SHINI claims no responsibility when:

- 1) Use of the conveyor belt is in any way openly opposed to what is indicated in the present instruction manual.
- 2) There are feeding defects.
- 3) There is a serious deficiency of the foreseen maintenance.
- 4) Non-authorized changes are adopted.
- 5) Spare parts that are non-authorized or not suitable for the actual model are used.
- 6) There are exceptional events. Please don't disassemble the protector sponge and quick tube & nip in the outlet of collecting material box.



Danger!

Risk of fire: Risk of fire is present whenever the conditions of the conveyor belts are not suitable for the operation they are used for (in particular: temperature of the pieces carried). Adjust the condition of the conveyor belt according to the table shown here below.



Risks of high temperature: These conveyor belts are designed for transporting molded parts, i.e. hot pieces. If you need to operate on the

conveyor belt, use safety gloves (in particular where the parts fall on the belt).

Type of belt	Max. temp. of parts
PVC	60°C



Attention!

The packing material must not be left around, and it must be disposed of according to the regulations in force. It is possible to lift the conveyor with a fork lift.



Danger!

To protect the operator's safety, and the integrity of the machine, assure the stable lifting of the conveyor. Once the conveyor belt is running, it is necessary to fix the machine by locking the castors. Moreover, suitable slings or fixtures must be attached, to keep it steady during transportation.

1.5 Exemption Clause

The following statements clarify the responsibilities and regulations born by any buyer or user who purchases products and accessories from Shini (including employees and agents).

Shini is exempted from liability for any costs, fees, claims and losses caused by reasons below:

1. Any careless or man-made installations, operation and maintenances upon machines without referring to the Manual prior to machine using.
2. Any incidents beyond human reasonable controls, which include man-made vicious or deliberate damages or abnormal power, and machine faults caused by irresistible natural disasters including fire, flood, storm and earthquake.
3. Any operational actions that are not authorized by Shini upon machine, including adding or replacing accessories, dismantling, delivering or repairing.
4. Employing consumables or oil media that are not appointed by Shini.

2. Structural Features and Working Principle

2.1 Function Description

CBD series conveyor feature reliable performance and ease of operation and are suitable for conveying finished products to separator to separate product from its connecting sprues. The height is adjustable.

2.1.1 Working Principle

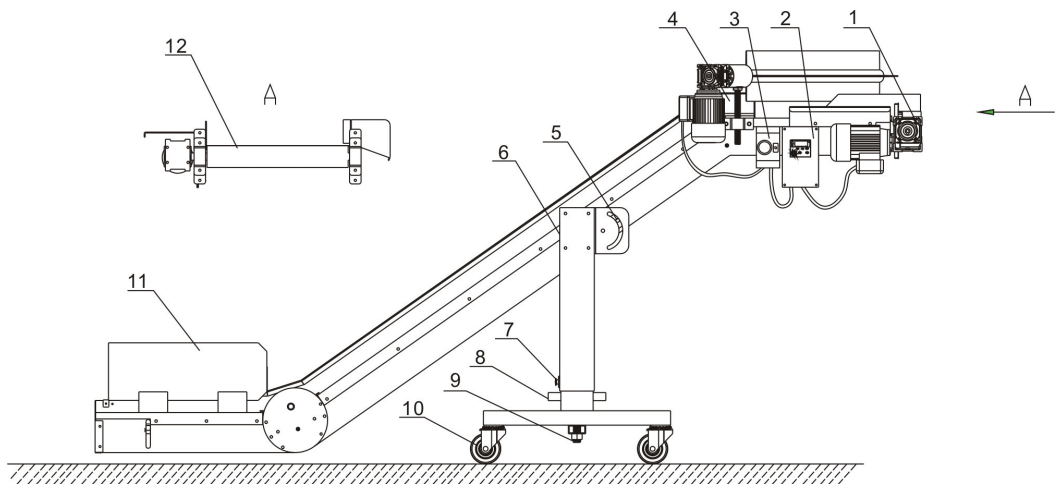

Parts name:

- | | | | |
|---------------------|------------------------|-------------------------|--------------|
| 1. Gear motor | 2. frequency converter | 3. Control switch | 4. Separator |
| 5. Adjustable bolt | 6. Floor stand | 7. Butterfly hand shaft | |
| 8. Driving wheel | 9. Main screw | 10. Castor | |
| 11. Material fender | | 12. Conveying rotor | |

Picture 2-1: Working Principle

The conveyor belts of this series are made up of:

Equipped with 4 castors and floor stand (6), the conveyor belt can be easily moved to the working area. There is a material fender (11) installed beside the conveying belt for collecting material. The conveying rotor (12) located on the top end is directly connect to the gear motor (1). The standard frequency converter (12) can adjust the speed of conveyor belt. The screw (9) controlled by the rotating wheel (8) can adjust the height of the conveyor belt. The two star knobs (7) can better lock the moving direction of the conveyor.

In addition, the separator (4) can separate different size of sprue and finished products by adjusting the screw. Generally speaking , the operator will stand at the conveyor top end (discharging area), and the controlling parts are located here as well.

3. Installation Testing

Read this chapter carefully before installation, Must observe the installation steps as follows!



The connection of the power supply should be done by qualified electricians only!

3.1 Attention

- 1) Verify that the power supply corresponds to the specifications of the plate near the controls of the conveyor.
- 2) Connect the power cable and the PE wire according to the local regulations.
- 3) Use independent power cable and switch, Make sure that the diameter of the cable is not smaller than the cable used in the control box.
- 4) The connection end of the power cable should be safely and tightly.
- 5) This series power adopts single phase power, and power L connects the power live wire, and N connects the earth wire.
- 6) Power supply requirement:
Main power voltage: $\pm 5\%$
Main power frequency: $\pm 2\%$
- 7) please refer to electrical drawing of each model to get the detailed power supply specifications.

3.2 Horizontal Installation

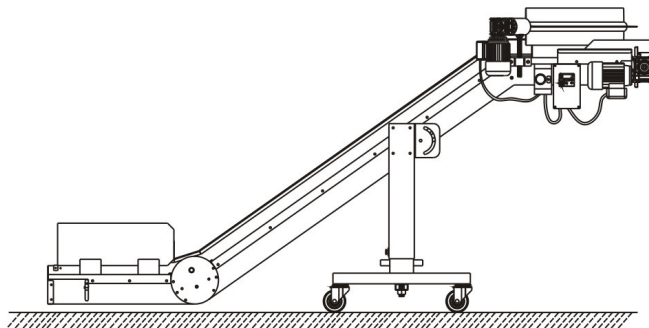

Picture 3-1: Installation Drawing

Conveyor don't require any particular preliminary operation before starting-up. With reference to the layout of the cables, make sure that they are protected against damage and that they don't hamper the operators.

Attention: The conveyor often used around the moulding machine to bring the waste materials or finished products from the bottom to the top, so that the lower flat surface (collection area) of the conveyor must be inserted into the special space, which is located under the mold of the moulding machine.

3.3 Power Connections

The control box of the CB Up-feed belt conveyor with separators should be connected to the power with the same regulations on the nameplate attached on it.

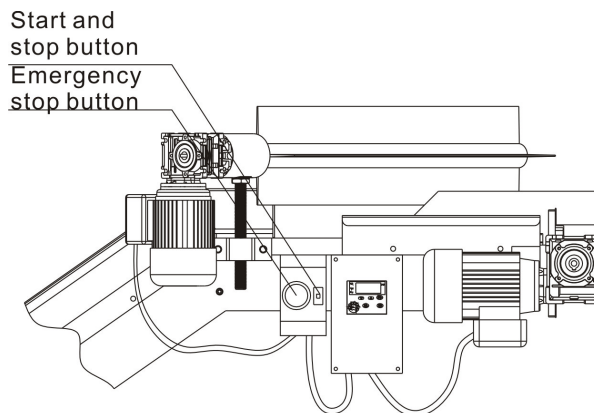

Picture 3-2: Power Connections

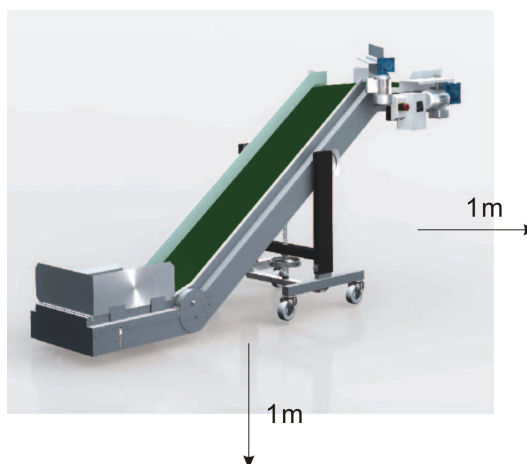

Picture 3-3: Machine Installation Drawing

4. Operation

4.1 Start / Stop the Machine

- 1) Rotate the motor protector knob, and connect to power.
- 2) After switching off the emergency button of thermomagnetic switch and pressing down the power switch, conveyor belt works.

4.2 Adjustment of the Height of the Conveyor

Loosen the locking butterfly knob(1), rotate the driving wheel(2), adjust the height, and then tighten the butterfly knob(1).

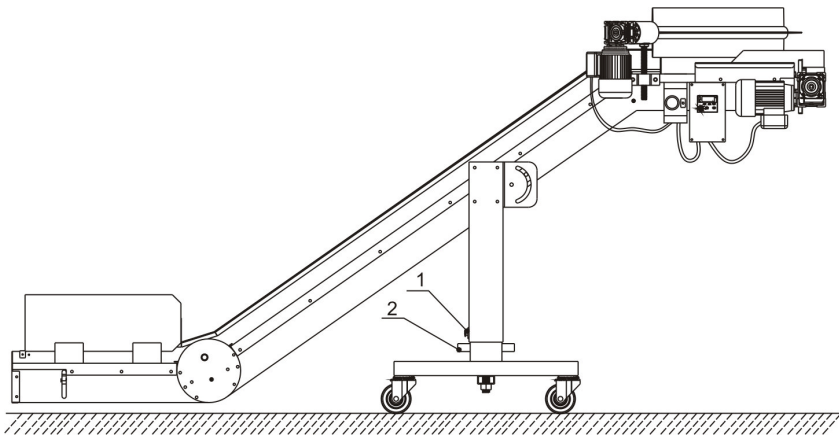

Picture 4-1: Conveyor Belt Adjusting Drawing

Attention: If the screw does not locked after adjustment, the conveyor belt will lost it's balance!

4.3 Adjusting the Central Space of the PU Belt

Rotate this nut to adjust the central space of the PU Belt

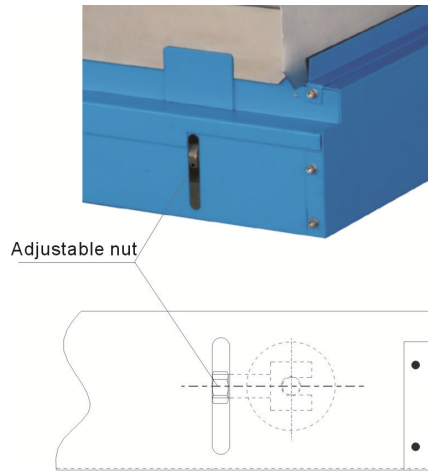

Picture 4-2: PU Adjusting Drawing



Danger!

To check the proper centering it is necessary to make the machine run. However, the adjustment must be done when the machine is stopped, and then the belt must be made to run only for the time necessary to verify its proper centering.



Attention!

On a monthly basis verify that the external temperature of the motor and gearbox is not too high (it should be between 60 and 20°C). In case it is different, contact the technicians at SHINI directly.



Attention!

- 1) The maximum weight of the pieces to be carried on the conveyor belt must not be over 56kg in total.
- 2) Not suitable to transport loose material.
- 3) The maximum resistant temperature of PU belt is 60°C.

4.4 Regulation of Sidewall

By rotating this screw bolt, position of the sidewall can be regulated to guide the direction of the belt.

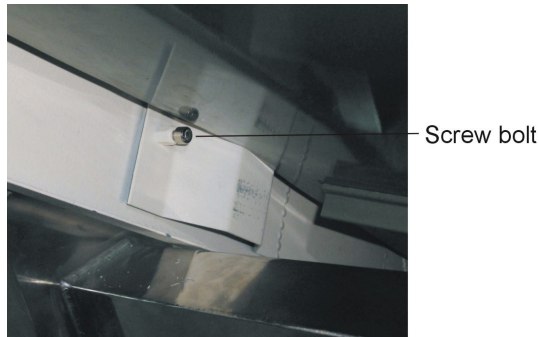

Picture 4-3: Regulation of Sidewall



The operator, or the maintenance technician, must wear suitable work clothes, without free parts. They must not wear chains, bracelets, or other objects which may be caught by mechanical parts in movement. In case of long hair, special hairnets must be used, to avoid the risk of being caught.

5. Trouble-shooting

Failures	Solutions
After power connection, switching off the switch emergency button and pressing down the power switch, motor doesn't work.	1. Check the circuit according to wiring diagram, the possible reasons can be as follows: a: The power is failure. b: The circuit is disconnected. c: The motor protector is damaged. d: The motor is failure.
The circuit breaker often trips off.	Check the circuit according to wiring diagram, the possible reasons can be as follows: a: The setting value of the breaker was too low, adjust the value to 1.1 times of the current one. b: Short circuit may exist. c: The motor protector is damaged. d: The motor is failure.

6. Service and Maintenance

Up-feed belt conveyors with separators do not require any particular maintenance.

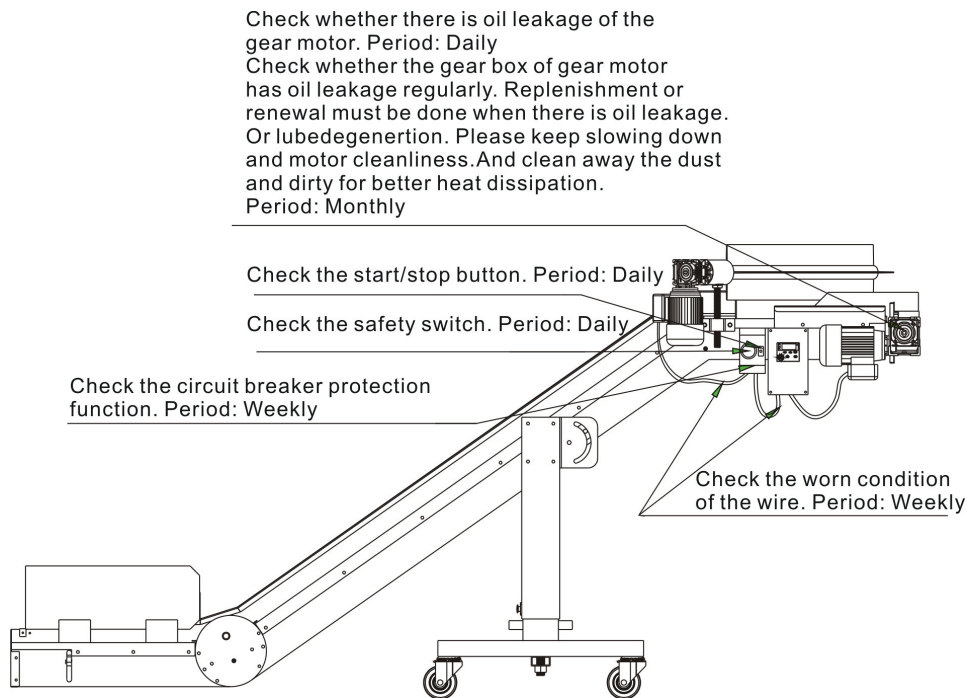

6.1 Repair

To avoid any body injury and damage of the machine, all of the repair work should be done by professional person only.

It is the duty of the operator to keep the machine clean from foreign matter, such as deposits, oil, or other materials. So it is necessary to clean the machine at the end of every working shift. This must be performed when the machine is stopped, in stable starting of the machine.

6.2 Maintenance

6.2.1 Maintenance of the Gear Motor

Regularly check the gears box. The lubricate oil in the gears box should be replaced after it has been run 400hr at the beginning, and after that the oil replacing periods is about 4,000hr. The lubricate oil in the gear motor must be sufficient. Replenishment or renewal must be done when there is oil leakage or

lube degeneration. Please keep the surface of the gear motor clean. Any dust and contamination are bad for heat dissipation.

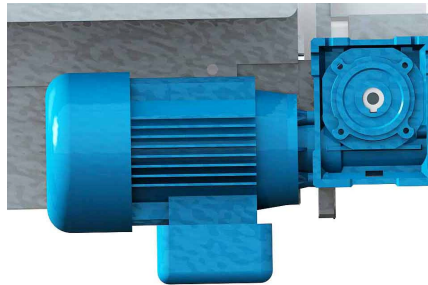

Picture 6-1: Gear motor

***Danger: Operating temperature range of gear motor is: 20°C
-60°C.***

6.2.2 Clearance of the Machine

Please keep the machine clean from foreign matter, such as deposits, oil, or other materials. Do the cleanly work everyday.



It is forbidden to use flammable liquids during the cleaning operation. Periodically check the status of the PU belt, and replace it, if necessary. Once the machine has been cleaned, the operator must check for worn out or damaged parts (in which case, he must replace it immediately), or for parts which are not firmly fixed (in which case, he should fix them, if this is possible).



The machine protection and safety devices must not be removed, unless a specific repair and/or maintenance action is required. These protections must be put back as soon as the reason for their removal has disappeared, in any case, they must be installed before starting the machine.



If using compressed air, the operator must wear safety glasses, and make sure that nobody is near the machine, because they may be hit by materials and dust.

6.2.3 Lubricate the Bearing

On a monthly basis lubricate the two supporters near the unloading area of the conveyor, below the protection cover, as indicated by the drawing.

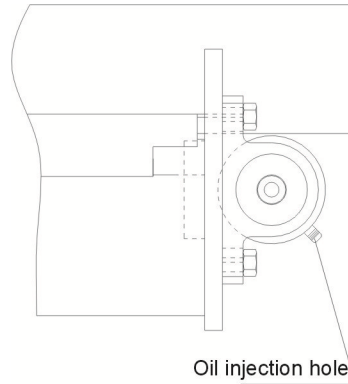

Picture 6-2: Bearing Lubricate Drawing

Stop the machine and unplug the power supply before doing the repair or maintenance work.

6.3 Maintenance Schedule

6.3.1 About the Machine

Model _____ SN _____ Manufacture date _____

Voltage _____ Φ _____ V Frequency _____ Hz Power _____ kW

6.3.2 Check After Installation

- Check if the body of the machine installed horizontal
- Check for eventual leaks of lubricant from the reduction gear
- Check the status about the PU belt

Electrical installation

- Voltage _____ V _____ Hz
- Check if the power connection of the control box is correctly

6.3.3 Daily Checking

- Check the switches of the machine.
- Check if the reduction gears is oil leaking leaking.
- Check the function of the safety switch.

6.3.4 Weekly Checking

- Check all the electrical wires.
- Check the protection function of the breaker.

6.3.5 Monthly Checking

The lubricate oil in the reduced gears of the motor should be replaced after it has been run 400hr at the beginning, The oil replacing periodis about 4,000hr,the oil in the reduced gears box should sufficiently, and need to check periodicity. When you find that the oil is reduced or the colour of it changed dark and black, you must complement it or replace it immediately.

7. Assembly Drawing

7.1 Spare Parts Drawing

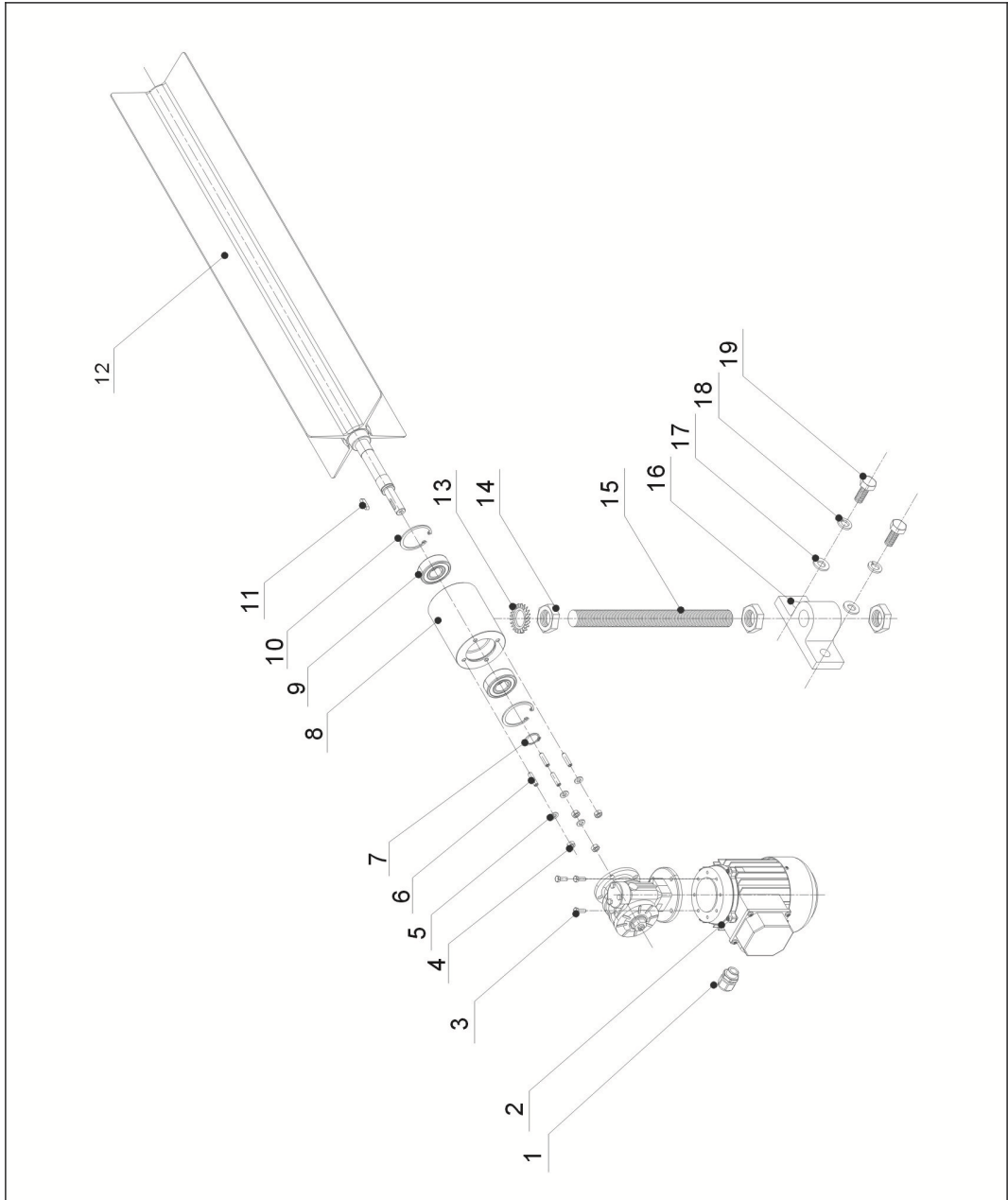

Note: Please refer to material list 7.2 about the parts code.

7.2 Spare Parts List

No.	Name	P/N
1	Cable terminal PG16	YE67001600000
2	Gear motor	YM50209000500
3	Hexagon screw bolt GB/T5783 M5x15-A2-70(SUS)	YW60051500000
4	Hexagon nut GB/T6170 M6-A2-70(SUS)	YW64000600100
5	Flat gasket A GB/T97.1 6(6.4x12x1.6)-A2-70(SUS)	YW66061200000
6	Inner hexagon cylindrical screw GB/T70.1 M6x25-A2-70(SUS)	YW61062500000
7	Spring gasket of the axis	YW69002200000
8	Bearing block	YW11020500200
9	Bearing 6204 ZZC3 NTN	YW11620400000
10	Spring gasket of the hole	YW69002200100
11	Key 5×5×20	YW69442000000
12	Assembly drawing of the separating axis	-
13	Lockup screw of the external sawtooth	-
14	Hexagon nut GB/T6171 M20x1.5-longzine	YW64200100000
15	Adjustable screw M20×220	-
16	Separator base	BH10120800110
17	Flat gasket 5.5x13x1 longzine	YW66051300000
18	Standard spring washer GB/T93 22	YW65022000000
19	Hexagon screw bolt GB/T5783 M12x20-8.8- longzine	YW60122500000

* means possible broken parts.

** means easy broken part. and spare backup is suggested.

Please confirm the version of manual before placing the purchase order to guarantee that the item number of the spare part is in accordance with the real object.

7.3 Base Parts Drawing

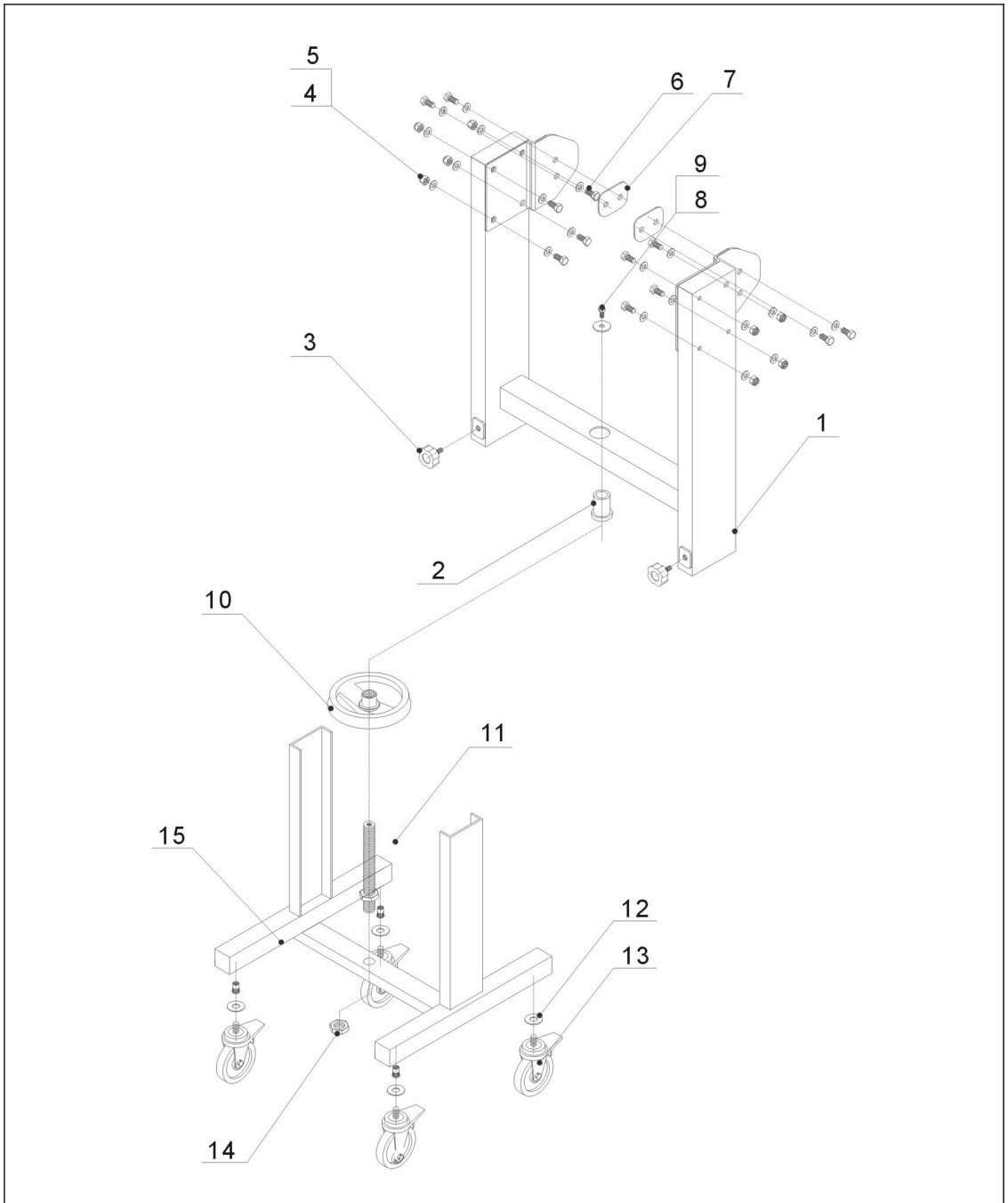

Note: Please refer to 7.4 material list about the parts code.

7.4 Base Parts List

No.	Name	P/N
1	Lifter	BH10110100010
2	Adjustable sleeve	BH10120300010
3	Hexagon screw	YW09101500100
4	Flat gasket 5.5x13x1-longzine	YW66051300000
5	Hexagon nut GB/T6170 M12-longzine	YW64012100000
6	Hexagon screw bolt GB/T5783 M8x60-12.9-longzine	YW60086000000
7	Adjust block	BH10121300040
8	Adjustable bolt	-
9	Gasket 16x40x5-longzine	YW66164000000
10	Driving wheel M27	YW09002700000
11	Main Screw M27	BH10120900040
12	Flat gasket A GB/T96 12(13x37x3) -longzine	YW66123200100
13	Castor	YW03010000000
14	Hexagon nut GB/T6170 M27-longzine	YW64002700000
15	Base	-

* means possible broken parts.

** means easy broken part. and spare backup is suggested.

Please confirm the version of manual before placing the purchase order to guarantee that the item number of the spare part is in accordance with the real object.

7.5 Spare Parts Drawing

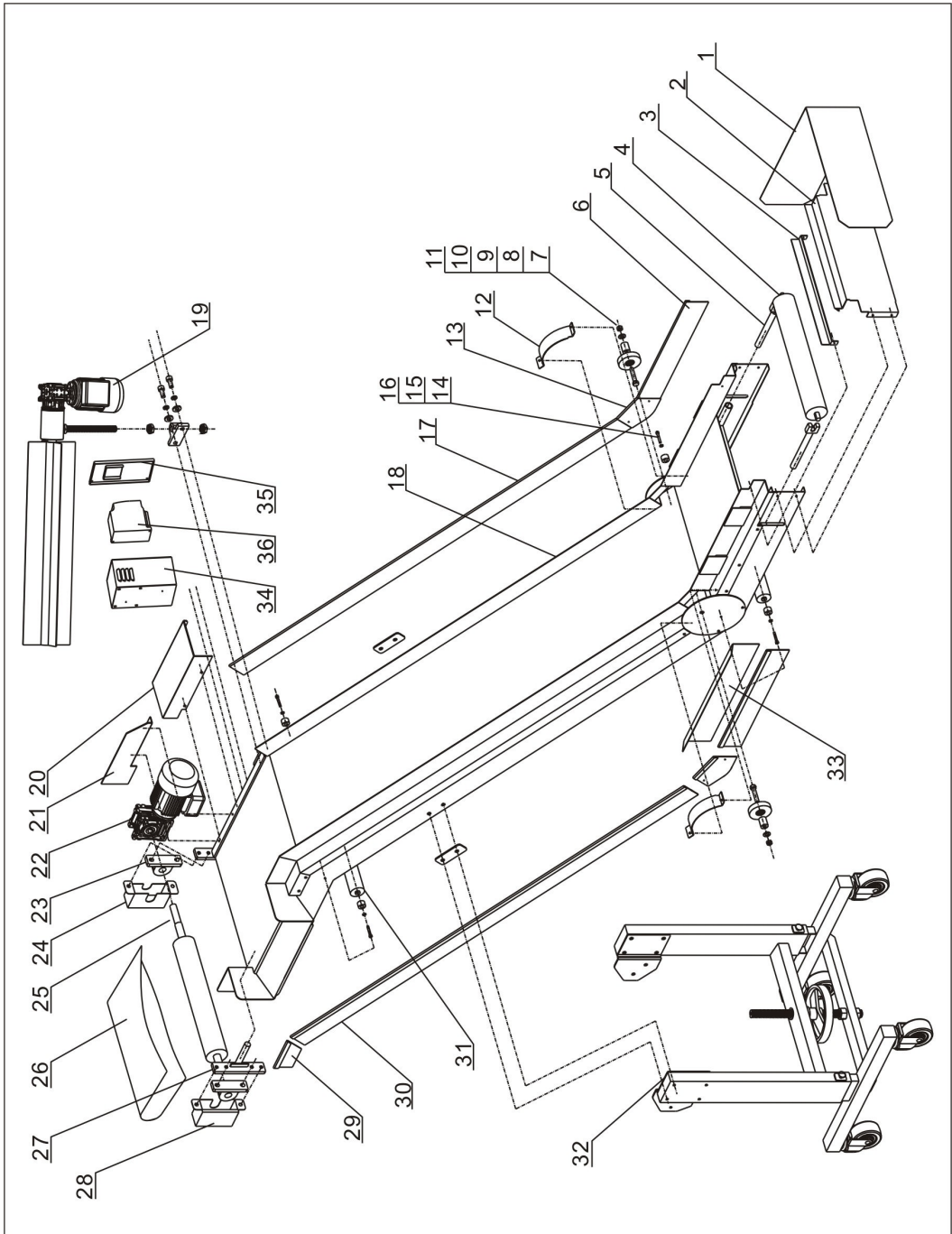

Note: Please refer to 7.6 material list about the parts code.

7.6 Parts List

CBD-7		
No.	Name	P/N
1	Reverse Flap	-
2	Front board	-
3	Front top board	-
4	Conveying rotor (without power)	-
5	Butterfly screw	BH10123500040
6	Front encircle board	-
7	Lock nut	YW64001200000
8	Flat gasket 5.5x13x1-longzine	YW66051300000
9	Sleeve for press out wheel	BH10120500010
10	Impaction roller assembly drawing	YW08120100000
11	External hexagonal screw M12x60	-
12	Pinch roller cover	-
13	Middle encircle board	-
14	Inner hexagonal screw M16x50	YW61065000000
15	Flat gasket A GB/T97.1 6 (6.4x12x1.6)-A2-70(SUS)	YW66061200000
16	Small sleeve	BH10123600010
17	Right middle board	-
18	Conveyor belt welding drawing	-
19	Separator parts list drawing	-
20	Switch protector board	-
21	Back right board	-
22	Gear motor *	YM50406000300
23	Bearing blockUCP205D1	YW11020500200
24	Right underside cover	-
25	Conveying rotor	YW08100500000
26	Conveyor belt	YR00070300000-
27	Left revolving axis support	-
28	Left below side cover board	-
29	Back left board	-
30	Left middle board	-
31	Iron stick	YW08100800000
32	Base parts list	-
33	Feed-in board	-
34	Frequency converter shell	-
35	Frequency converter cover	-
36	Frequency converter	YE75004200600

Please confirm the version of manual before placing the purchase order to guarantee that the item number of the spare part is in accordance with the real object.

CBD-8		
No.	Name	P/N
1	Reverse Flap	-
2	Front board	-
3	Front top board	-
4	Conveying rotor (without power)	YW08100700000
5	Butterfly screw	BH10123500040
6	Front encircle board	-
7	Lock nut	YW64001200000
8	Flat gasket 5.5x13x1-longzine	YW66051300000
9	Sleeve for press out wheel	BH10120500010
10	Impaction roller assembly drawing	YW08120100000
11	External hexagonal screw M12x60	-
12	Pinch roller cover	-
13	Middle encircle board	-
14	Inner hexagonal screw M6×50	YW61065000000
15	Flat gasket A GB/T97.1 6(6.4x12x1.6)-A2-70(SUS)	YW66061200000
16	Small sleeve	BH10123600010
17	Right middle board	-
18	Conveyor belt welding drawing	-
19	Separator parts list drawing	-
20	Switch protector board	-
21	Back right board	-
22	Gear motor *	YM50406000300
23	Bearing blockUCP205D1	YW11020500200
24	Right underside cover	-
25	Conveying rotor	YW08110500000
26	Conveyor belt	YR00080300000
27	Left revolving axis support	-
28	Left below side cover board	-
29	Back left board	-
30	Left middle board	-
31	Iron stick	YW08110800000
32	Base parts list	-
33	Feed-in board	-
34	Frequency converter shell	-
35	Frequency converter cover	-
36	Frequency converter	YE75004200600

Please confirm the version of manual before placing the purchase order to guarantee that the item number of the spare part is in accordance with the real object.

CBD-9		
No.	Name	P/N
1	Reverse Flap	-
2	Front board	-
3	Front top board	-
4	Conveying rotor (without power)	YW08100700000
5	Butterfly screw	BH10123500040
6	Front encircle board	-
7	Lock nut	YW64001200000
8	Flat gasket 5.5x13x1-longzine	YW66051300000
9	Sleeve for press out wheel	BH10120500010
10	Impaction roller assembly drawing	YW08120100000
11	External hexagonal screw M12x60	-
12	Pinch roller cover	-
13	Middle encircle board	-
14	Inner hexagonal screw M6x50	YW61065000000
15	Flat gasket A GB/T97.1 6(6.4x12x1.6)-A2-70(SUS)	YW66061200000
16	Small sleeve	BH10123600010
17	Right middle board	-
18	Conveyor belt welding drawing	-
19	Separator parts list drawing	-
20	Switch protector board	-
21	Back right board	-
22	Gear motor *	YM50406000300
23	Bearing blockUCP205D1	YW11020500200
24	Right underside cover	-
25	Conveying rotor	YW08100500000
26	Conveyor belt	YR00090700000
27	Left revolving axis support	-
28	Left below side cover board	-
29	Back left board	-
30	Left middle board	-
31	Iron stick	YW08100800000
32	Base parts list	-
33	Feed-in board	-
34	Frequency converter shell	-
35	Frequency converter cover	-
36	Frequency converter	YE75004200600

Please confirm the version of manual before placing the purchase order to guarantee that the item number of the spare part is in accordance with the real object.

CBD-10		
No.	Name	P/N
1	Reverse Flap	-
2	Front board	-
3	Front top board	-
4	Conveying rotor (without power)	YW08100700000
5	Butterfly screw	BH10123500040
6	Front encircle board	-
7	Lock nut	YW64001200000
8	Flat gasket 5.5x13x1-longzine	YW66051300000
9	Sleeve for press out wheel	BH10120500010
10	Impaction roller assembly drawing	YW08120100000
11	External hexagonal screw M12x60	-
12	Pinch roller cover	-
13	Middle encircle board	-
14	Inner hexagonal screw M6x50	YW61065000000
15	Flat gasket A GB/T97.1 6(6.4x12x1.6)-A2-70(SUS)	YW66061200000
16	Small sleeve	BH10123600010
17	Right middle board	-
18	Conveyor belt welding drawing	
19	Separator parts list drawing	-
20	Switch protector board	-
21	Back right board	-
22	Gear motor *	YM50406000300
23	Bearing blockUCP205D1	YW11020500200
24	Right underside cover	-
25	Conveying rotor	YW08100500000
26	Conveyor belt	YR00101200000
27	Left revolving axis support	-
28	Left below side cover board	-
29	Back left board	-
30	Left middle board	-
31	Iron stick	YW08100800000
32	Base parts list	-
33	Feed-in board	-
34	Frequency converter shell	-
35	Frequency converter cover	-
36	Frequency converter	YE75004200600

Please confirm the version of manual before placing the purchase order to guarantee that the item number of the spare part is in accordance with the real object.

CBD-11		
No.	Name	P/N
1	Reverse Flap	-
2	Front board	-
3	Front top board	-
4	Conveying rotor (without power)	YW08110700000
5	Butterfly screw	BH10123500040
6	Front encircle board	-
7	Lock nut	YW64001200000
8	Flat gasket 5.5x13x1-longzine	YW66051300000
9	Sleeve for press out wheel	BH10120500010
10	Impaction roller assembly drawing	YW08120100000
11	External hexagonal screw M12x60	-
12	Pinch roller cover	-
13	Middle encircle board	-
14	Inner hexagonal screw M6x50	YW61065000000
15	Flat gasket A GB/T97.1 6(6.4x12x1.6)-A2-70(SUS)	YW66061200000
16	Small sleeve	BH10123600010
17	Right middle board	-
18	Conveyor belt welding drawing	-
19	Separator parts list drawing	-
20	Switch protector board	-
21	Back right board	-
22	Gear motor *	YM50406000300
23	Bearing block UCP205D1	YW11020500200
24	Right underside cover	-
25	Conveying rotor UCP205D2	YW08110500000
26	Conveyor belt	YR00111200000
27	Left revolving axis support	-
28	Left below side cover board	-
29	Back left board	-
30	Left middle board	-
31	Iron stick	YW08110800000
32	Base parts list	-
33	Feed-in board	-
34	Frequency converter shell	-
35	Frequency converter cover	-
36	Frequency converter	YE75004200600

Please confirm the version of manual before placing the purchase order to guarantee that the item number of the spare part is in accordance with the real object.

CBD-12		
No.	Name	P/N
1	Reverse Flap	-
2	Front board	-
3	Front top board	-
4	Conveying rotor (without power)	YW08100700000
5	Butterfly screw	BH10123500040
6	Front encircle board	-
7	Lock nut	YW64001200000
8	Flat gasket 5.5x13x1-longzine	YW66051300000
9	Sleeve for press out wheel	BH10120500010
10	Impaction roller assembly drawing	YW08120100000
11	External hexagonal screw M12x60	-
12	Pinch roller cover	-
13	Middle encircle board	-
14	Inner hexagonal screw M6x50	YW61065000000
15	Flat gasket A GB/T97.1 6(6.4x12x1.6)-A2-70(SUS)	YW66061200000
16	Small sleeve	BH10123600010
17	Right middle board	-
18	Conveyor belt welding drawing	-
19	Separator parts list drawing	-
20	Switch protector board	-
21	Back right board	-
22	Gear motor *	YM50406000300
23	Bearing blockUCP205D1	YW11020500200
24	Right underside cover	-
25	Conveying rotor	YW08100500000
26	Conveyor belt	YR00124700000
27	Left revolving axis support	-
28	Left below side cover board	-
29	Back left board	-
30	Left middle board	-
31	Iron stick	YW08100800000
32	Base parts list	-
33	Feed-in board	-
34	Frequency converter shell	-
35	Frequency converter cover	-
36	Frequency converter	YE75004200600

Please confirm the version of manual before placing the purchase order to guarantee that the item number of the spare part is in accordance with the real object.

