

SDD Series

Dehumidifying Dryers

Date: Oct, 2010

Version: V4.0 (English)



Contents

1. General Description	3
1.1 Feature	3
1.2 Technical Specifications	3
1.2.1 Specifications	3
1.2.2 Outline Drawing	3
1.2.3 Drying Capacity.....	3
1.3 Safety Regulations	3
1.3.1 Safety Regulations for the Blowers	3
1.3.2 Safety Signs and Labels	3
1.3.3 Transportation and Storage of the Machine	3
2. Structure Characteristics and Working Principle	3
2.1 Working Principle.....	3
2.2 Relative Humidity and Dew-point.....	3
2.3 Why Choose SDD	3
2.4 Working Principle.....	3
2.5 Hygrometric Equivalentents.....	3
2.6 Comparison of Air Dew-point.....	3
2.7 Drawing and Parts List	3
2.7.1 Structural Drawing	3
2.7.2 Assembly Drawing	3
2.7.3 Parts List	3
2.7.4 Pipe Heaters	3
2.7.5 Honeycomb Rotor	3
2.8 Electrical Diagram	3
2.8.1 Electrical Diagram.....	3
2.8.2 Main Circuit (PCB)	3
2.8.3 Control Circuit (PCB)	3
2.8.4 Thermocouple Wiring Diagram (PCB).....	3
2.8.5 Components Layout (PCB)	3
2.8.6 Electrical Components List (PCB).....	3
2.8.7 Main Circuit (PLC).....	3

2.8.8	Control Circuit (PLC).....	3
2.8.9	Thermocouple Wiring Diagram (PLC).....	3
2.8.10	Components Layout (PLC).....	3
2.8.11	Electrical Components List (PLC).....	3
2.8.12	Main Electrical Components Description.....	3
2.9	Operation Procedures	3
2.9.1	Operation Regulations	3
2.9.2	Description of Touch Screen.....	3
2.9.3	Touch Panel Appear Error	3
2.9.4	Dew-point Monitor.....	3
3.	Installation Testing	3
3.1	Attention	3
3.2	Honeycomb-rotor.....	3
3.2.1	What is Honeycomb-rotor	3
3.2.2	Installation of the Rotor	3
3.3	Heater Assemblies	3
3.3.1	EGO.....	3
4.	Operating.....	3
4.1	Control Panel.....	3
4.2	Panel Operation.....	3
4.3	Temperature Setup.....	3
4.4	PID Auto-tuning Setting.....	3
4.5	Intermittent Running Setup.....	3
4.6	Weekly Time Start Setup.....	3
4.7	Present Time Modification	3
4.8	Weekly Time Start	3
4.9	Lock Setup Way	3
4.10	The second level of Advanced Setting	3
4.11	Wrong Codes Remark	3
4.12	Installation for Dewpoint Monitor	3
5.	Trouble-shooting	3
6.	Maintenance and Repair.....	3
6.1	Honeycomb-rotor.....	3

6.1.1 H Model of Honeycomb-rotor	3
6.2 Filter	3
6.2.1 The Useful Life of the Key Parts of the Product	3
6.3 Cooler Clear Step	3
6.4 Maintenance Schedule	3
6.4.1 General Machine Information	3
6.4.2 Check After Installation	3
6.4.3 Daily Checking	3
6.4.4 Weekly Checking	3
6.4.5 Monthly Checking	3
6.4.6 Half-yearly Checking	3

Table Index

Table 1-1 : Specifications	3
Table 1-2 : Drying Capacity 1	3
Table 1-3 : Drying Capacity 2	3
Table 2-1 : Hygrometric Equivalentents.....	3
Table 2-2 : Parts List (SDD-20U/30H~80U/50H)	3
Table 2-3 : Parts List (SDD-120U/50H~160U/120H)	3
Table 2-4 : Parts List (SDD-230U/120H~300U/200H)	3
Table 2-5 : Parts List (SDD-450U/200H~600U/300H)	3
Table 2-6 : Parts List (SDD-600U/400H~900U/500H)	3
Table 2-7 : Parts List (SDD-900U/500H~1200U/700H)	3
Table 2-8 : Electrical Diagram 1	3
Table 2-9 : Electrical Diagram 2	3
Table 2-10 : Electrical Components List (PCB) (SDD-20U/40U-30H)	3
Table 2-11 : Electrical Components List (PCB) (SDD-40U/80U-50H)	3
Table 2-12 : Electrical Components List (PCB) (SDD-120U/160U-80H)	3
Table 2-13 : Electrical Components List (PCB) (SDD-160U/230U-120H)	3
Table 2-14 : Electrical Components List (PCB) (SDD-230U/300U-150H)	3
Table 2-15 : Electrical Components List (PCB) (SDD-300U/450U-200H)	3
Table 2-16 : Electrical Components List (PCB) (SDD-450U/600U-300H)	3
Table 2-17 : Electrical Components List (PCB) (SDD-600U/750U-400H)	3

Table 2-18 : Electrical Components List (PCB) (SDD-750U/900U-500H)	3
Table 2-19 : Electrical Components List (PCB) (SDD-900U/1200U-700H)	3
Table 2-20 : Electrical Components List (PLC) (SDD-20U/30H)	3
Table 2-21 : Electrical Components List (PLC) (SDD-40U/30H)	3
Table 2-22 : Electrical Components List (PLC) (SDD-40U/50H)	3
Table 2-23 : Electrical Components List (PLC) (SDD-80U/50H)	3
Table 2-24 : Electrical Components List (PLC) (SDD-120U/80H).....	3
Table 2-25 : Electrical Components List (PLC) (SDD-160U/80H).....	3
Table 2-26 : Electrical Components List (PLC) (SDD-160U/120H).....	3
Table 2-27 : Electrical Components List (PLC) (SDD-230U/120H).....	3
Table 2-28 : Electrical Components List (PLC) (SDD-230U/150H).....	3
Table 2-29 : Electrical Components List (PLC) (SDD-300U/150H).....	3
Table 2-30 : Electrical Components List (PLC) (SDD-300U/200H).....	3
Table 2-31 : Electrical Components List (PLC) (SDD-450U/300H).....	3
Table 2-32 : Electrical Components List (PLC) (SDD-600U/300H).....	3
Table 2-33 : Electrical Components List (PLC) (SDD-600U/400H).....	3
Table 2-34 : Electrical Components List (PLC) (SDD-750U/400H).....	3
Table 2-35 : Electrical Components List (PLC) (SDD-750U/500H).....	3
Table 2-36 : Electrical Components List (PLC) (SDD-900U/500H).....	3
Table 2-37 : Electrical Components List (PLC) (SDD-900U/700H).....	3
Table 2-38 : Electrical Components List (PLC) (SDD-1200U/700H).....	3
Table 4-2 : Wrong Codes Remark	3

Picture Index

Picture 1-1 : Outline Drawing.....	3
Picture 1-2 : Safety Regulations for the Blowers	3
Picture 1-3 : Safety Signs and Labels.....	3
Picture 2-1 : Working Principle	3
Picture 2-2 : Comparison of Air Dew-point	3
Picture 2-3 : Structural Drawing.....	3
Picture 2-4 : Assembly Drawing.....	3
Picture 2-5 : Pipe Heaters	3
Picture 2-6 : Honeycomb Rotor	3

Picture 2-7 : Main Circuit 1 (PCB).....	3
Picture 2-8 : Main Circuit 2(PCB).....	3
Picture 2-9 : Control Circuit (PCB).....	3
Picture 2-10 : Thermocouple Wiring Diagram (PCB).....	3
Picture 2-11 : Components Layout (PCB)	3
Picture 2-12 : Main Circuit 1 (PLC).....	3
Picture 2-13 : Main Circuit 2 (PLC).....	3
Picture 2-14 : Control Circuit (PLC).....	3
Picture 2-15 : Thermocouple Wiring Diagram (PLC)	3
Picture 2-16 : Components Layout (PLC).....	3
Picture 2-17 : Overload Relay	3
Picture 2-18 : Operation Regulations.....	3
Picture 2-19 : Description of Touch Screen	3
Picture 2-20 : Screen Operation Flow Table.....	3
Picture 2-21 : System Default System.....	3
Picture 2-22 : Drying Process Screen.....	3
Picture 2-23 : Temperature Parameters Setting 1	3
Picture 2-24 : Temperature Parameters Setting 2	3
Picture 2-25 : Process temp. Parameters setting 1	3
Picture 2-26 : Process temp. Parameters setting 2	3
Picture 2-27 : Rotor Parameter Setting.....	3
Picture 2-28 : Time Setting	3
Picture 2-29 : Time Setting 2	3
Picture 2-30 : Alarm Fault Records.....	3
Picture 2-31 : Help menu	3
Picture 2-32 : Embedded Dew-point Monitor.....	3
Picture 2-33 : Detachable Dew-point Monitor	3
Picture 3-1 : Installation Drawing.....	3
Picture 3-2 : Honeycomb Rotor	3
Picture 3-3 : Installation of the Rotor	3
Picture 3-4 : Heater Assemblies	3
Picture 3-5 : EGO	3
Picture 4-1 : Control Panel	3
Picture 4-2 : Intermittent running setup 1.....	3

Picture 4-3 : Intermittent running setup 2.....	3
Picture 4-4 : Intermittent running setup 3.....	3
Picture 4-5 : Weekly Time Start Setup 1.....	3
Picture 4-6 : Weekly Time Start Setup 2.....	3
Picture 4-7 : Weekly Time Start Setup 3.....	3
Picture 4-8 : Weekly Time Start Setup 4.....	3
Picture 4-9 : Weekly Time Start Setup 5.....	3
Picture 4-10 : Hole Site.....	3
Picture 4-11 : Parts of Dew-point Monitor.....	3
Picture 4-12 : Copper Joint Assembly of Original Machine.....	3
Picture 4-13 : Installation Seat.....	3
Picture 4-14 : Installation for Transmitter.....	3
Picture 4-15 : Connection of Signal Wire.....	3
Picture 4-16 : Installation for Dew-point Monitor.....	3
Picture 4-17 : Connection of Dew-point Monitor.....	3
Picture 6-1 : Filter.....	3

1. General Description



Please read through this operation manual before using the machine to prevent damages of the machine or personal injuries.

SDD series dehumidifying dryers combine dehumidifying and drying systems into a single unit. They have many applications in processing plastic materials, such as PA, PC, PBT, PET etc. All models feature SD-H honeycomb dehumidifiers with built-in process heater and insulated drying hopper. Under ideal conditions, it can provide dehumidified dry air with a dew-point lower than -40 .



SDD-160U/120H-LC-D



SDD-160U/120H

1.1 Feature

- 1) The SDD dehumidifying dryers use honeycomb dehumidifiers with an eye-catching semi-integral appearance.
- 2) Each model combines dehumidifying and drying functions into a single unit.
- 3) Insulated drying hopper features dry air down-blowing and cyclone exhaust design. This improves drying efficiency and reduces energy consumption while maintain a steady drying effect.
- 4) The dehumidifying section of the SDD series features two condensers to ensure a low return air temperature and low dew-point.
- 5) Compact in size for ease of movement and space saving.
- 6) Material processing is controlled via microprocessor as standard, with PLC touch screen control as an option for more convenient control.
- 7) Dew-point monitor can be fitted to check dry air dew-point.
- 8) Optional suction box and hopper loader for added convenience when conveying material.
- 9) Upon request, it can be built to comply with worldwide electrical safety standards (For example: CE, UL, CSA, JIS etc.).

All service work should be carried out by a person with technical training or corresponding professional experience. The manual contains instructions for both handling and servicing. Chapter 6, which contains service instructions intended for service engineers. Other chapters contain instructions for the daily operator.

Any modifications of the machine must be approved by SHINI in order to avoid personal injury and damage to machine. We shall not be liable for any damage caused by unauthorized change of the machine.

Our company provides excellent after-sales service. Should you have any problem during using the machine, please contact the company or the local vendor.

Headquarter and Taipei factory : Hot service line on Mainland :

Tel: (886) 2 2680 9119

Tel: 800 999 3222

1.2 Technical Specifications

1.2.1 Specifications

Table 1-1 : Specifications

Model	Regen. Heater (kW)	Process Blower (kW)(50/60Hz)	Process Heater (kW)	Regen. blower (kW) (50/60Hz)	Dry air Capacity (m ³ /hr)(50/60Hz)	Insulated Hopper (L)	Dimensions (mm) H×W×D	Weight (kg)
20U/30H	3	0.18 / 0.2	3	0.2 / 0.2	30 / 35	20	1240×875×810	110
40U/30H	3	0.18 / 0.2	3	0.2 / 0.2	30 / 35	40	1300×930×810	190
40U/50H	3	0.18 / 0.2	3.9	0.4 / 0.5	50 / 60	40	1300×930×810	190
80U/50H	3	0.18 / 0.2	3.9	0.4 / 0.5	50 / 60	80	1410×1030×810	210
120U/80H	3	0.18 / 0.2	6	0.75 / 0.9	80 / 95	120	1780×1220×855	250
160U/80H	3	0.18 / 0.2	6	0.75 / 0.9	80 / 95	160	1740×1220×855	255
160U/120H	3	0.18 / 0.2	6	0.75 / 0.9	120 / 130	160	1740×1220×855	265
230U/120H	3	0.18 / 0.2	6	0.75 / 0.9	120 / 130	230	2010×1220×855	295
230U/150H	4	0.4 / 0.5	7.2	1.5 / 1.8	150 / 170	230	2150×1450×1050	375
300U/150H	4	0.4 / 0.5	7.2	1.5 / 1.8	150 / 170	300	2040×1450×1050	410
300U/200H	4	0.4 / 0.5	7.2	1.5 / 1.8	200 / 220	300	2040×1450×1050	420
450U/200H	4	0.4 / 0.5	7.2	1.5 / 1.8	200 / 220	450	2440×1450×1050	550
450U/300H	7.2	0.75 / 0.9	15	2.4 / 3	300 / 340	450	2480×1490×1255	580
600U/300H	7.2	0.75 / 0.9	15	2.4 / 3	300 / 340	600	2380×1745×1255	615
600U/400H	7.2	0.75 / 0.9	18	3.75 / 4.5	400 / 450	600	2380×1745×1255	620
750U/400H	7.2	0.75 / 0.9	18	3.75 / 4.5	400 / 450	750	2610×1745×1255	650
750U/500H	10	1.5 / 1.8	21	5.5 / 6.3	500 / 570	750	2760×2140×1380	760
900U/500H	10	1.5 / 1.8	21	5.5 / 6.3	500 / 570	900	2640×2140×1380	820
900U/700H	10	1.5 / 1.8	24	5.5 / 6.3	700 / 780	900	2640×2140×1380	830
1200U/700H	10	1.5 / 1.8	24	5.5 / 6.3	700 / 780	1200	3070×2140×1380	870

Note: 1) Power supply: 3Φ, 230 / 400 / 460 / 575V, 50 / 60Hz.

2) Mark "HT " at the back of models when 180 high-temp is requested.

We reserve the right to change specifications without prior notice.

1.2.2 Outline Drawing

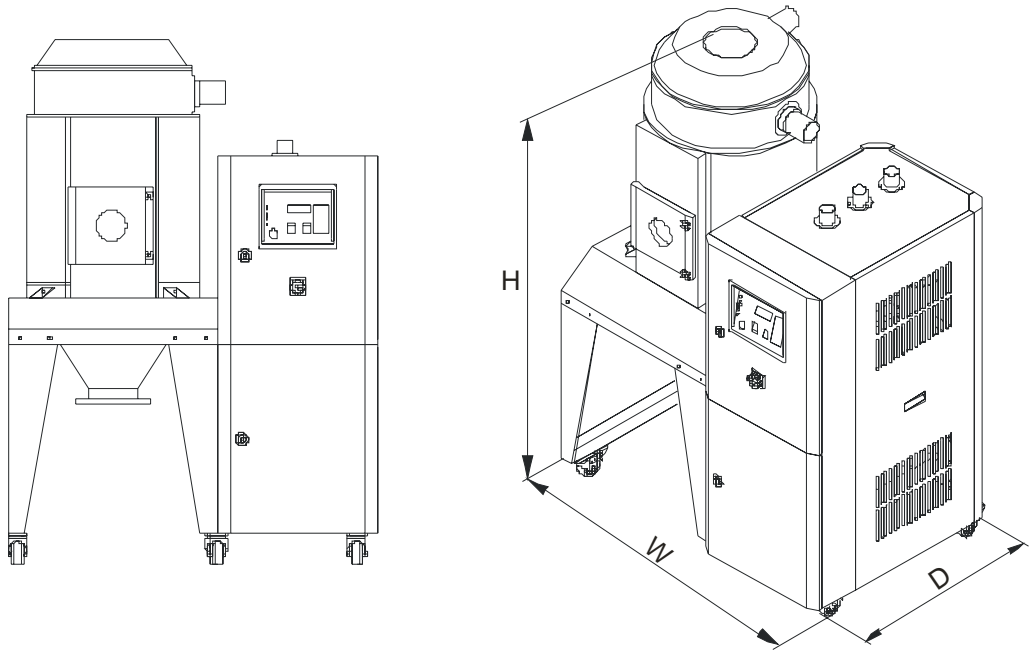

Picture 1-1 : Outline Drawing

1.2.3 Drying Capacity

Table 1-2 : Drying Capacity 1

Material	Drying Temp. ()	Drying Time (hr)	Drying Capacity (kg/hr)										
			20U /30H	40U /30H	40U /50H	80U /50H	120U /80H	160U /80H	160U /120H	230U /120H	230U /150H	300U /150H	300U /200H
ABS	80	2-3	11		18		27		35		71		106
CA	75	2-3	9		15		22		29		59		88
CAB	75	2-3	9		15		22		29		59		88
CP	75	2-3	11		18		27		35		71		106
LCP	150	4	8		13		40		27		53		80
POM	100	2	16		27		40		53		106		159
PMMA	80	3	11		19		29		38		77		115
IONOMER	90	3-4	7		11		17		22		44		66
PA6/6.6/6.10	75	4-6	6		10		14		19		38		58
PA11	75	4-5	7		12		17		23		46		69
PA12	75	4-5	7		12		17		23		46		69
PC	120	2-3	13		21		31		41		83		124
PU	90	2-3	11		19		29		38		77		115
PBT	130	3-4	9		15		23		31		62		93
PE	90	1	32		53		80		106		212		318
PEI	150	3-4	8		13		20		27		53		80
PET	160	4-6	8		13		19		25		50		75
PETG	70	3-4	8		13		20		27		53		80
PEN	170	5	9		15		23		30		60		90
PES	150	4	9		15		23		30		60		90
PMMA	80	3	11		19		29		38		77		115
PPO	110	1-2	13		22		33		44		88		133
PPS	150	3-4	8		13		20		27		53		80
PI	120	2	16		27		40		53		106		159
PP	90	1	26		44		66		88		177		265
PS(GP)	80	1	26		44		66		88		177		265
PSU	120	3-4	8		14		22		29		58		86
PVC	70	1-2	13		22		33		44		88		133
SAN(AS)	80	1-2	13		22		33		44		88		133
TPE	110	3	13		21		31		41		83		124

Note! Please refer to above drying capacity of SCD machine, select the right model according to material usage of processing machine.

Table 1-3 : Drying Capacity 2

Material	Drying Temp. ()	Drying Time (hr)	Drying Capacity (kg/hr)						
			450U /300H	600U /300H	600U /400H	750U /400H	750U /500H	900U /500H	900U /700H
ABS	80	2-3	180		210		285		355
CA	75	2-3	150		180		235		295
CAB	75	2-3	150		180		235		295
CP	75	2-3	180		210		285		355
LCP	150	4	135		160		210		365
POM	100	2	265		320		425		530
PMMA	80	3	192		230		307		383
IONOMER	90	3-4	111		133		177		220
PA6/6.6/6.10	75	4-6	96		115		153		192
PA11	75	4-5	115		138		184		230
PA12	75	4-5	115		138		184		230
PC	120	2-3	206		250		330		413
PU	90	2-3	190		230		307		383
PBT	130	3-4	155		186		248		310
PE	90	1	531		637		850		1062
PEI	150	3-4	133		160		212		265
PET	160	4-6	125		150		200		250
PETG	70	3-4	133		160		212		265
PEN	170	5	150		180		240		300
PES	150	4	150		180		240		300
PMMA	80	3	190		230		310		385
PPO	110	1-2	220		265		355		440
PPS	150	3-4	133		160		212		265
PI	120	2	265		320		425		530
PP	90	1	442		530		710		885
PS(GP)	80	1	442		531		708		885
PSU	120	3-4	145		173		230		290
PVC	70	1-2	220		265		355		442
SAN(AS)	80	1-2	220		265		355		442
TPE	110	3	205		250		330		413

Note! Please refer to above drying capacity of SCD machine, select the right model according to material usage of processing machine.

1.3 Safety Regulations



Warning!

Electrical installation should be done by qualified technician only.

Before connecting to AC Power Source, turn power switch to OFF position.

While AC power source is connected, make sure specifications and overload protection rating of the power switch are suitable and reliable.

When the machine is under care or maintenance status, turn both power switch and automatic operation switch to off.

1.3.1 Safety Regulations for the Blowers

- 1) Under normal operation, the blowers will generate high temperature. Do not touch blower's case to avoid any physical injury.
- 2) Under normal operation, the blower motor's current loading will increase or reduce according to air pressure's change accordingly. While installation, an adequate motor overload protection switch should be installed with full loading test, to ensure operating safely under full-loading to avoid motor's damage.
- 3) To avoid any block materials, dust, powder, fiber particles and water drops entering the blower, and hence cause the deficiency of its performance. This machine is well designed with air filters, so please clean up the filter with any foreign particles (recommended to clean up this filter weekly).
- 4) Clean the blowers both internal and external parts (especially for the fan cooling path), and remove surface dust if necessary. If more dusts are accumulated, it will cause deficiency for ventilation, temperature rising, vacuum power reduced, vibration increased and so it will cause machine broke down.
- 5) Ball bearing, oil seal and soundproof are belonging to consumable parts and so it has a life period and requires regular replacement. Meanwhile, blade, external case, and metallic screen etc. should be replaced regularly for best performance.
- 6) Under normal operation, if the blowers are not running smoothly or abnormal noise appeared. Please immediately shut down the machine for repair.



Picture 1-2 : Safety Regulations for the Blowers

1.3.2 Safety Signs and Labels



Danger!

High voltage danger!

This label is stuck on the electrical boxes.



Attention!

This label means that this area should be taken care!



Warning!

High temperature, take care of hands!

This label should be stick to the shell of heater.



Attention!

No need for regular inspection because all the electrical parts in the control unit are fixed tightly!



Picture 1-3 : Safety Signs and Labels

1.3.3 Transportation and Storage of the Machine

Transportation

- 1) SDD series dehumidifying dryers are packed in crates or plywood cases with wooden pallet at the bottom, suitable for quick positioning by fork lift.
- 2) After unpacked, castors equipped on the machine can be used for ease of movement.
- 3) Do not rotate the machine and avoid collision with other objects during transportation to prevent improper functioning.
- 4) The structure of the machine is well-balanced, although it should also be handled with care when lifting the machine for fear of falling down.
- 5) The machine and its attached parts can be kept at a temperature from -25 to +55 for long distance transportation and for a short distance, it can be transported with temperature under +70 .

Storage

- 1) SDD series dehumidifying dryers should be stored indoors with temperature kept from 5 to 40 and humidity below 80%.
- 2) Disconnect all power supply and turn off main switch and control switch.
- 3) Keep the whole machine, especially the electrical components away from water to avoid potential troubles caused by the water.
- 4) Plastic film should be used to protect the machine from dust and rains.

Working environment

Indoors in a dry environment with max. temperature +45 and humidity no more than 80%.

Do not use the machine

- 1) If it is with a damaged cord.

- 2) On a wet floor or when it is exposed to rain to avoid electrical shock.
- 3) If it has been dropped or damaged until it is checked or fixed by a qualified serviceman.
- 4) This equipment works normally in the environment with altitude within 3000m.
- 5) At least a clearance of 1m surrounding the equipment is required during operation. Keep this equipment away from flammable sources at least two meters.
- 6) Avoid vibration, magnetic disturbance at the operation area.

Rejected parts disposal

When the equipment has run out its life time and can not be used any more, unplug the power supply and dispose of it properly according to local code.

Fire hazard



In case of fire, CO₂ dry powder fire extinguisher should be applied.

2. Structure Characteristics and Working Principle

2.1 Working Principle

In the process of material treating, SDD de-moisture and drying group integrates drying and de-moisture functions into one unit, mainly used for drying the plastics with strong hygroscopic characters, such as PA, PC, PBT, PET, etc. Its basic principle is to blow out the hot and moisture air from the dry hopper drum. After filtering and cooling the hot air, blow it into the honey comb rotation wheel. The moisture contained in the air will be absorbed by the rotation wheel, hereafter, will be de-absorbed by the re-generated heating air. The two air-streams work together in the rotation wheel. With the rotation of the wheel, the moisture will be absorbed and de-absorbed by the re-generated air to drain out continuously, and to form a steady low dew point air. After that, heat this air until it reaches the dry temperature of plastics, blow it into dry hopper drum to form a closed loop to short the drying time and improve drying efficiency.

2.2 Relative Humidity and Dew-point

Relative humidity: Relative air humidity means real vapor content to saturated vapor at the same temperature in percentage.

Dew point: it means that temperature when the saturation vapor begins to dew. When the relative humidity is 100%, the ambient temperature is the dew point temperature. The more lower of dew point temperature (than the ambient temperature) is, the more less possible to dew, that also means the more drier the air is. The dew point will not be influenced by temperature, but influenced by pressure.

2.3 Why Choose SDD

It is proved that the hygroscopic materials used in the plastics industry such as: PC, PA, PBT, PET, Nylon and etc. cannot be dried effectively by conventional hot air drying systems because those systems depend on ambient conditions and are relatively inefficient in reducing moisture contents. These materials demand steady low dew point dry air and a constant drying temperature, which guarantee final moisture content of 0.02% or even less. The SDD provides a closed-loop system with the dew-point of the dry air being down to -40 or even

lower which accelerates the moisture transferring from the plastic granules to the dry air.

2.4 Working Principle

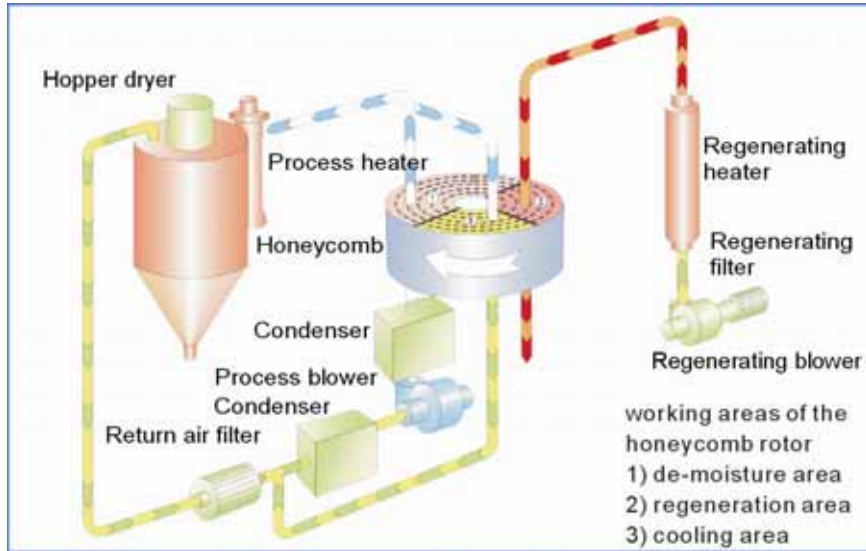

Picture 2-1 : Working Principle

2.5 Hygrometric Equivalents

Table 2-1 : Hygrometric Equivalents

Dew-point ()	Relative humidity (%)	Moisture content	
		PPM	%
+20	100	23,072	2.307
+10	52.5	12,117	1.212
0	26.10	6,027	0.603
-10	11.20	2,574	0.257
-20	4.40	1,025	0.103
-30	1.60	378	0.038
-40	0.60	128	0.013
-50	0.20	39	0.004

2.6 Comparison of Air Dew-point

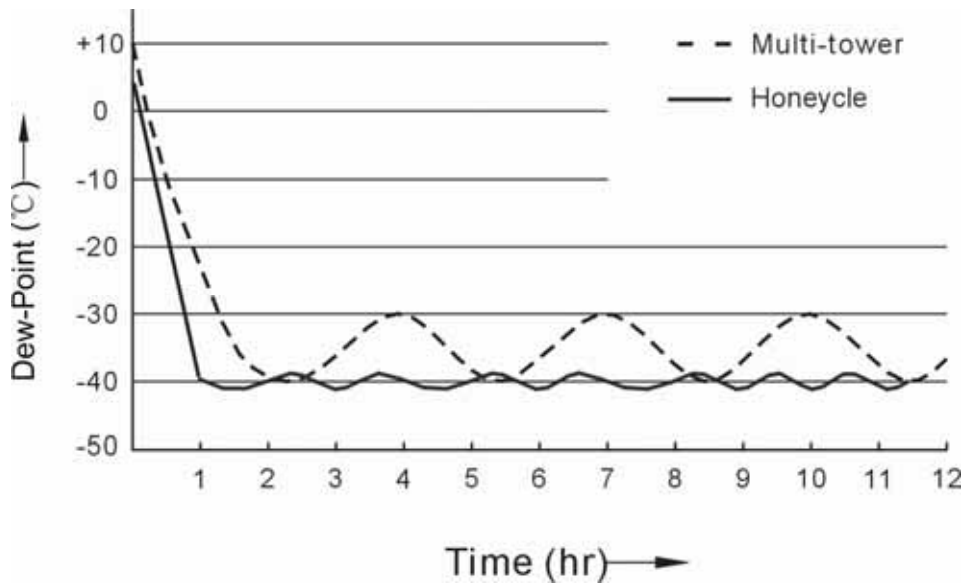

Picture 2-2 : Comparison of Air Dew-point

2.7 Drawing and Parts List

2.7.1 Structural Drawing

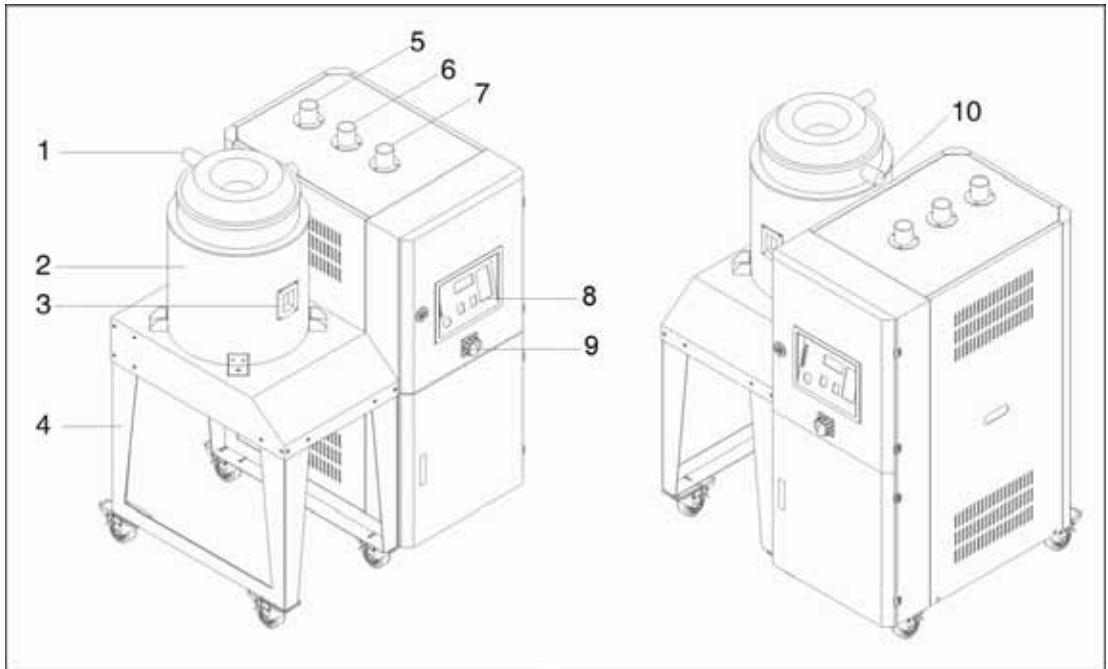

Parts name:

- | | | | |
|--|----------------------|---------------------|--------------------|
| 1. Return air outlet | 2. Insulated hopper | | |
| 3. Sight-glass window (or material clearance door for hopper capacity more than 80U) | | | |
| 4. Floor stand | 5. Dry air outlet | 6. Return air inlet | 7. Moisture outlet |
| 8. Control panel | 9. Main power switch | 10. Dry air inlet | |

Picture 2-3 : Structural Drawing

2.7.2 Assembly Drawing

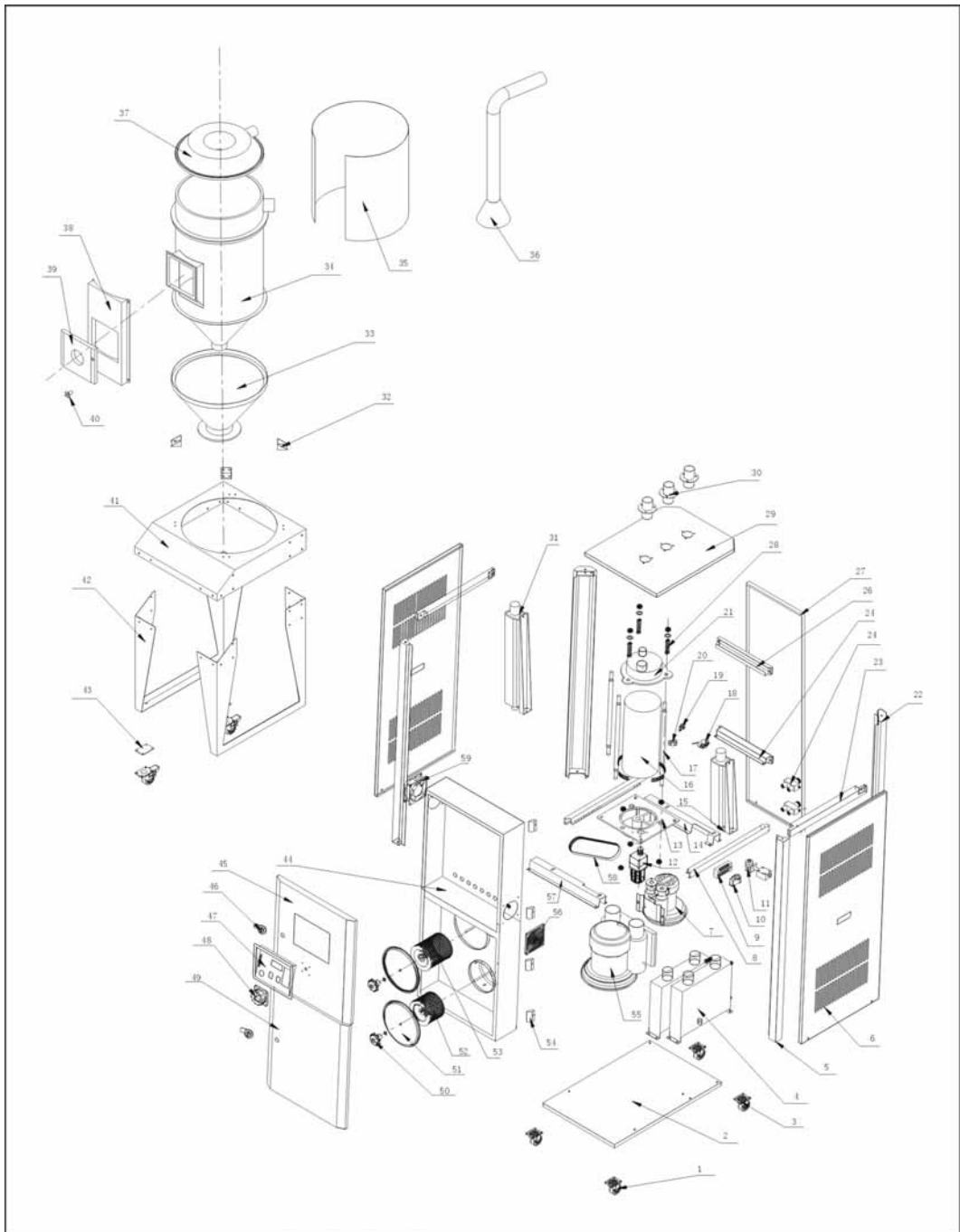

Remarks: Please refer to material list 2.7.3 for specific explanation of the Arabic numbers in parts drawing.

Picture 2-4 : Assembly Drawing

2.7.3 Parts List

Table 2-2 : Parts List (SDD-20U/30H~80U/50H)

No.	Description	Part No.			
		20U/30H	40U/30H	40U/50H	80U/50H
1	Castor (red)	YW03000300200	YW03000300200	YW03000300200	YW03000300200
2	Bottom plate	-	-	-	-
3	Castor brake	YW03000300000	YW03000300000	YW03000300000	YW03000300000
4	Condenser	BW88030500020	BW88030500020	BW88030500020	BW88030500020
5	Front pole	-	-	-	-
6	Side plate	-	-	-	-
7	Blower *	BM30012500050	BM30012500050	BM30020500050	BM30020500050
8	Side middle beam	-	-	-	-
9	Terminal board	YE61250000000	YE61250000000	YE61250000000	YE61250000000
10	Capacitor	YE25001500000	YE25001500000	YE25001500000	YE25001500000
11	Belt adjustor square block	BH10005000040	BH10005000040	BH10005000040	BH10005000040
12	Gear motor	YM50102600000	YM50102600000	YM50102600000	YM50102600000
13	Honeycomb bottom cover	BA40003000010	BA40003000010	BA40508000010	BA40508000010
14	Rear middle beam	-	-	-	-
15	Regen. heater*	BH70300300050	BH70300300050	BH70500300050	BH70500300050
16	Honeycomb	YW71152000100	YW71152000100	YW71182000100	YW71182000100
17	Two-head screw	BH10533000010	BH10533000010	BH10533000010	BH10533000010
18	Microswitch *	YE14152400000	YE14152400000	YE14152400000	YE14152400000
19	Fixed seat of Microswitch (left smaller one)	YR40000100300	YR40000100300	YR40000100300	YR40000100300
20	Fixed seat of Microswitch (right bigger one)	YR40000100200	YR40000100200	YR40000100200	YR40000100200
21	Honeycomb upper cover	BA40003000110	BA40003000110	BA40508000110	BA40508000110
22	Rear pole	-	-	-	-
23	Side beam	-	-	-	-
24	Water distributor	-	-	-	-
25	Rear middle beam	-	-	-	-
26	Rear fixing beam	-	-	-	-
27	Rear plate	-	-	-	-
28	Spring	YW01201800000	YW01201800000	YW01201800000	YW01201800000
29	Top cover	-	-	-	-
30	Flange	-	-	-	-
31	Process heater*	BH70160600150	BH70403900150	BH70803900150	BH70803900150

No.	Description	Part No.			
		20U/30H	40U/30H	40U/50H	80U/50H
32	Outer fastener	-	-	-	-
33	Outer hopper cone	-	-	-	-
34	Material hopper	-	-	-	-
35	Hopper tank cover	-	-	-	-
36	Down-blowing pipe	-	-	-	-
37	Hopper top	-	-	-	-
38	Door frame	-	-	-	-
39	Sight glass window	-	-	-	-
40	Butterfly nut	YW09051600000	YW09051600000	YW09051600000	YW09051600000
41	Stand plate	-	-	-	-
42	Stand fixer	-	-	-	-
43	Castor fixer	-	-	-	-
44	Control box	BH34405000250	BH34405000250	BH34405000250	BH34405000250
45	Upper door plate	-	-	-	-
46	Door lock	YW00000600000	YW00000600000	YW00000600000	YW00000600000
47	Control panel	YR01003000200	YR01003000200	YR01003000200	YR01003000200
48	Main power supply switch*	YE10200300000	YE10200300000	YE10200300000	YE10210300000
49	Lower door plate	-	-	-	-
50	Butterfly nut	YW09051600000	YW09051600000	YW09051600000	YW09051600000
51	Filter cover	-	-	-	-
52	ADC18 filter**	YR50128300000	YR50128300000	YR50128300000	YR50128300000
53	Filter**	YR50128300000	YR50128300000	YR50128300000	YR50128300000
54	Hinge	YW06203100200	YW06203100200	YW06203100200	YW06203100200
55	Motor *	BM30012500050	BM30012500050	BM30012500050	BM30012500050
56	Anti-dust net	YR40120300000	YR40120300000	YR40120300000	YR40120300000
57	Front middle beam	-	-	-	-
58	Transmission belt**	YR00202200000	YR00202200000	YR00202500000	YR00202500000
59	Cooling fan**	YM60121200400	YM60121200400	YM60121200400	YM60121200400

* means possible broken parts.

** means easy broken part. and spare backup is suggested.

Please confirm the version of manual before placing the purchase order to guarantee that the item number of the spare part is in accordance with the real object.

Table 2-3 : Parts List (SDD-120U/50H~160U/120H)

No.	Description	Part No.		
		120U/80H	160U/80H	160U/120H
1	Castor (red)	YW03000300200	YW03000300200	YW03000300200
2	Bottom plate	-	-	-
3	Castor brake	YW03000300000	YW03000300000	YW03000300000
4	Condenser	BW88081200020	BW88081200020	BW88081200020
5	Front pole	-	-	-
6	Side plate	-	-	-
7	Blower *	BM30031000150	BM30031000150	BM30031000150
8	Side middle beam	-	-	-
9	Terminal board	YE61250000000	YE61250000000	YE61250000000
10	Capacitor	YE25001500000	YE25001500000	YE25001500000
11	Belt adjustor square block	BH10005000040	BH10005000040	BH10005000040
12	Gear motor	YM50102600000	YM50102600000	YM50102600000
13	Honeycomb bottom cover	BA40508000010	BA40508000010	BA40508000010
14	Rear middle beam	-	-	-
15	Regen. heater*	BH70800300050	BH70800300050	BH70800300050
16	Honeycomb	YW71183000100	YW71183000100	YW71184000100
17	Two-head screw	BH10543000010	BH10543000010	BH10554500010
18	Microswitch *	YE14152400000	YE14152400000	YE14152400000
19	Fixed seat of Microswitch (left smaller one)	YR40000100300	YR40000100300	YR40000100300
20	Fixed seat of Microswitch (right bigger one)	YR40000100200	YR40000100200	YR40000100200
21	Honeycomb upper cover	BA40508000110	BA40508000110	BA40508000110
22	Rear pole	-	-	-
23	Side beam	-	-	-
24	Water distributor	-	-	-
25	Rear middle beam	-	-	-
26	Rear fixing beam	-	-	-
27	Rear plate	-	-	-
28	Spring	YW01201800000	YW01201800000	YW01201800000
29	Top cover	-	-	-
30	Flange	-	-	-
31	Process heater*	BH70120600150	BH70160600150	BH70230600150
32	Outer fastener	-	-	-
33	Outer hopper cone	-	-	-

No.	Description	Part No.		
		120U/80H	160U/80H	160U/120H
34	Material hopper	-	-	-
35	Hopper tank cover	-	-	-
36	Down-blowing pipe	-	-	-
37	Hopper top	-	-	-
38	Door frame	-	-	-
39	Sight glass window	-	-	-
40	Butterfly nut	YW09051600000	YW09051600000	YW09051600000
41	Stand plate	-	-	-
42	Stand fixer	-	-	-
43	Castor fixer	-	-	-
44	Control box	BH34012000450	BH34168000350	BH34016000350
45	Upper door plate	-	-	-
46	Door lock	YW00000600000	YW00000600000	YW00000600000
47	Control panel	YR01003000200	YR01003000200	YR01003000200
48	Main power supply switch*	YE10210300000	YE10210300000	YE10210300000
49	Lower door plate	-	-	-
50	Butterfly nut	YW09051600000	YW09051600000	YW09051600000
51	Filter cover	-	-	-
52	ADC18 filter**	YR50128300000	YR50128300000	YR50128300000
53	Filter**	YR50708000100	YR50708000100	YR50708000100
54	Hinge	YW06203100200	YW06203100200	YW06203100200
55	Motor *	BM30012500050	BM30012500050	BM30012500050
56	Anti-dust net	YR40120300000	YR40120300000	YR40120300000
57	Front middle beam	-	-	-
58	Transmission belt**	YR00202500000	YR00202500000	YR00202500000
59	Cooling fan**	YM60121200400	YM60121200400	YM60121200400

* means possible broken parts.

** means easy broken part. and spare backup is suggested.

Please confirm the version of manual before placing the purchase order to guarantee that the item number of the spare part is in accordance with the real object.

Table 2-4 : Parts List (SDD-230U/120H~300U/200H)

No.	Description	Part No.			
		230U/120H	230U/150H	300U/150H	300U/200H
1	Castor (red)	YW03000300200	YW03000300200	YW03000300200	YW03000300200
2	Bottom plate	-	-	-	-
3	Castor brake	YW03000300000	YW03000300000	YW03000300000	YW03000300000
4	Condenser	BW88152000020	BW88152000020	BW88152000020	BW88152000020
5	Front pole	-	-	-	-
6	Side plate	-	-	-	-
7	Blower *	BM30012500050	BM30020500050	BM30020500050	BM30020500050
8	Side middle beam	-	-	-	-
9	Terminal board	YE61250000000	YE61250000000	YE61250000000	YE61250000000
10	Capacitor	YE25001500000	YE25001500000	YE25001500000	YE25001500000
11	Belt adjustor square block	BH10005000040	BH10005000040	BH10005000040	BH10005000040
12	Gear motor	YM50102600000	YM50102600000	YM50102600000	YM50102600000
13	Honeycomb bottom cover	BA40508000010	BA40152000010	BA40152000010	BA40152000010
14	Rear middle beam	-	-	-	-
15	Regen. heater*	BH70800300050	BH70150400050	BH70150400050	BH70200400050
16	Honeycomb	YW71184000100	YW71253000100	YW71253000100	YW71254000100
17	Two-head screw	BH10554500010	BH10543000010	BH10543000010	BH10554500010
18	Microswitch *	YE14152400000	YE14152400000	YE14152400000	YE14152400000
19	Fixed seat of Microswitch (left smaller one)	YR40000100300	YR40000100300	YR40000100300	YR40000100300
20	Fixed seat of Microswitch (right bigger one)	YR40000100200	YR40000100200	YR40000100200	YR40000100200
21	Honeycomb upper cover	BA40508000110	BA40152000110	BA40152000110	BA40152000110
22	Rear pole	-	-	-	-
23	Side beam	-	-	-	-
24	Water distributor	-	-	-	-
25	Rear middle beam	-	-	-	-
26	Rear fixing beam	-	-	-	-
27	Rear plate	-	-	-	-
28	Spring	YW01201800000	YW01201800000	YW01201800000	YW01201800000
29	Top cover	-	-	-	-
30	Flange	-	-	-	-
31	Process heater*	BH70230600150	BH70230600150	BH70307200150	BH70307200150
32	Outer fastener	-	-	-	-
33	Outer hopper cone	-	-	-	-
34	Material hopper	-	-	-	-

No.	Description	Part No.			
		230U/120H	230U/150H	300U/150H	300U/200H
35	Hopper tank cover	-	-	-	-
36	Down-blowing pipe	-	-	-	-
37	Hopper top	-	-	-	-
38	Door frame	-	-	-	-
39	Sight glass window	-	-	-	-
40	Butterfly nut	YW09051600000	YW09051600000	YW09051600000	YW09051600000
41	Stand plate	-	-	-	-
42	Stand fixer	-	-	-	-
43	Castor fixer	-	-	-	-
44	Control box	BH34231200250	BH34231500250	BH34231500250	BH34302000250
45	Upper door plate	-	-	-	-
46	Door lock	YW00000600000	YW00000600000	YW00000600000	YW00000600000
47	Control panel	YR01003000200	YR01003000200	YR01003000200	YR01003000200
48	Main power supply switch*	YE10210300000	YE10210300000	YE10210300000	YE10250400000
49	Lower door plate	-	-	-	-
50	Butterfly nut	YW09051600000	YW09051600000	YW09051600000	YW09051600000
51	Filter cover	-	-	-	-
52	ADC18 filter**	YR50708000100	YR50708000100	YR50708000100	YR50708000100
53	Filter***	YR50708000100	YR50181100000	YR50203000000	YR50203000000
54	Hinge	YW06203100200	YW06203100200	YW06203100200	YW06203100200
55	Motor *	BM30031000150	BM30042000050	BM30042000050	BM30042000050
56	Anti-dust net	YR40120300000	YR40120300000	YR40120300000	YR40120300000
57	Front middle beam	-	-	-	-
58	Transmission belt***	YR00203400000	YR00203400000	YR00203400000	YR00203400000
59	Cooling fan**	YM60121200400	YM60121200400	YM60121200400	YM60121200400

* means possible broken parts.

** means easy broken part. and spare backup is suggested.

Please confirm the version of manual before placing the purchase order to guarantee that the item number of the spare part is in accordance with the real object.

Table 2-5 : Parts List (SDD-450U/200H~600U/300H)

No.	Description	Part No.		
		450U/200H	450U/300H	600U/300H
1	Castor (red)	YW03000300200	YW03000300200	YW03000400200
2	Bottom plate	-	-	-
3	Castor brake	YW03000300000	YW03000300000	YW03000400000
4	Condenser	BW88152000020	BW88304000020	BW88304000020
5	Front pole	-	-	-
6	Side plate	-	-	-
7	Blower *	BM30020500050	BM30031000150	BM30031000150
8	Side middle beam	-	-	-
9	Terminal board	YE61250000000	YE61250000000	YE61250000000
10	Capacitor	YE25001500000	YE25001500000	YE25001500000
11	Belt adjustor square block	BH10005000040	BH10005000040	BH10005000040
12	Gear motor	YM50102600000	YM50512600000	YM50512600000
13	Honeycomb bottom cover	BA40152000010	BA40152000010	BA40304000110
14	Rear middle beam	-	-	-
15	Regen. heater*	BH70200400050	BH70307200250	BH70307200250
16	Honeycomb	YW71254000100	YW71353000100	YW71353000100
17	Two-head screw	BH10554500010	BH10543000010	YW71353000100
18	Microswitch *	YE14152400000	YE14152400000	YE14152400000
19	Fixed seat of Microswitch (left smaller one)	YR40000100300	YR40000100300	YR40000100300
20	Fixed seat of Microswitch (right bigger one)	YR40000100200	YR40000100200	YR40000100200
21	Honeycomb upper cover	BA40152000110	BA40152000110	BA40304000010
22	Rear pole	-	-	-
23	Side beam	-	-	-
24	Water distributor	-	-	-
25	Rear middle beam	-	-	-
26	Rear fixing beam	-	-	-
27	Rear plate	-	-	-
28	Spring	YW01201800000	YW01201800000	YW01180300000
29	Top cover	-	-	-
30	Flange	-	-	-
31	Process heater*	BH70451200150	BH70451200150	BH70601500150
32	Outer fastener	-	-	-
33	Outer hopper cone	-	-	-

No.	Description	Part No.		
		450U/200H	450U/300H	600U/300H
34	Material hopper	-	-	-
35	Hopper tank cover	-	-	-
36	Down-blowing pipe	-	-	-
37	Hopper top	-	-	-
38	Door frame	-	-	-
39	Sight glass window	-	-	-
40	Butterfly nut	YW09051600000	YW09051600000	YW09001000000
41	Stand plate	-	-	-
42	Stand fixer	-	-	-
43	Castor fixer	-	-	-
44	Control box	BH34452000350	BH34453000250	BH34603000250
45	Upper door plate	-	-	-
46	Door lock	YW00000600000	YW00000600000	YW00000600000
47	Control panel	YR01003000200	YR01003000200	YR01003000200
48	Main power supply switch*	YE10250400000	YE40636300000	YE40636300000
49	Lower door plate	-	-	-
50	Butterfly nut	YW09051600000	YW09051600000	YW09001000000
51	Filter cover	-	-	-
52	ADC18 filter**	YR50708000100	YR50708000100	YR50708000100
53	Filter**	YR50181100000	YR50181100000	YR50241400000
54	Hinge	YW06203100200	YW06203100200	YW06203100200
55	Motor *	BM30042000050	YM30052900000	YM30052900000
56	Anti-dust net	YR40120300000	YR40120300000	YR40120300000
57	Front middle beam	-	-	-
58	Transmission belt**	YR00203400000	YR00204700000	YR00204700000
59	Cooling fan**	YM60121200400	YM60121200400	YM60121200400

* means possible broken parts.

** means easy broken part. and spare backup is suggested.

Please confirm the version of manual before placing the purchase order to guarantee that the item number of the spare part is in accordance with the real object.

Table 2-6 : Parts List (SDD-600U/400H~900U/500H)

No.	Description	Part No.		
		600U/400H	750U/400H	750U/500H
1	Castor (red)	YW03000400000	YW03000400000	YW03000400000
2	Bottom plate	-	-	-
3	Castor brake	YW03000400000	YW03000400000	YW03000400000
4	Condenser	BW88304000020	BW88304000020	YR30010400000
5	Front pole	-	-	-
6	Side plate	-	-	-
7	Blower *	BM30031000150	BM30031000150	BM30042000050
8	Side middle beam	-	-	-
9	Terminal board	YE61250000000	YE61250000000	YE61250000000
10	Capacitor	YE25001500000	YE25001500000	YE25001500000
11	Belt adjustor square block	BH10005000040	BH10005000040	BH10005000040
12	Gear motor	YM50512600000	YM50512600000	YM50512600000
13	Honeycomb bottom cover	BA40304000110	BA40304000110	BA40507000010
14	Rear middle beam	-	-	-
15	Regen. heater*	BH70100000050	BH70100000050	BH70501000050
16	Honeycomb	YW71354000100	YW71354000100	YW71443000100
17	Two-head screw	BH10554500010	BH10554500010	BH10543000010
18	Microswitch *	YE14152400000	YE14152400000	YE14152400000
19	Fixed seat of Microswitch (left smaller one)	YR40000100300	YR40000100300	YR40000100300
20	Fixed seat of Microswitch (right bigger one)	YR40000100200	YR40000100200	YR40000100200
21	Honeycomb upper cover	BA40304000010	BA40304000010	BA40507000110
22	Rear pole	-	-	-
23	Side beam	-	-	-
24	Water distributor	-	-	-
25	Rear middle beam	-	-	-
26	Rear fixing beam	-	-	-
27	Rear plate	-	-	-
28	Spring	YW01180300000	YW01180300000	YW01180300000
29	Top cover	-	-	-
30	Flange	-	-	-
31	Process heater*	BH70601500150	BH70601500150	BH70751800150
32	Outer fastener	-	-	-
33	Outer hopper cone	-	-	-

No.	Description	Part No.		
		600U/400H	750U/400H	750U/500H
34	Material hopper	-	-	-
35	Hopper tank cover	-	-	-
36	Down-blowing pipe	-	-	-
37	Hopper top	-	-	-
38	Door frame	-	-	-
39	Sight glass window	-	-	-
40	Butterfly nut	YW09051600000	YW09051600000	YW09051600000
41	Stand plate	-	-	-
42	Stand fixer	-	-	-
43	Castor fixer	-	-	-
44	Control box	BH34604000150	BH34754000150	BH34755000150
45	Upper door plate	-	-	-
46	Door lock	YW00000600000	YW00000600000	YW00000600000
47	Control panel	YR01003000200	YR01003000200	YR01003000200
48	Main power supply switch*	YE40636300000	YE40636300000	YE40601500000
49	Lower door plate	-	-	-
50	Butterfly nut	YW09051600000	YW09051600000	YW09051600000
51	Filter cover	-	-	-
52	ADC18 filter**	YR50708000100	YR50708000100	YW03000200000
53	Filter**	YR50241400000	YR50241400000	YR50241400000
54	Hinge	YW06203100200	YW06203100200	YW06203100200
55	Motor *	YM30062900000	YM30062900000	YM30072900000
56	Anti-dust net	YR40120300000	YR40120300000	YR40120300000
57	Front middle beam	-	-	-
58	Transmission belt**	YR00204700000	YR00204700000	YR00205800000
59	Cooling fan**	YM60121200400	YM60121200400	YM60121200400

* means possible broken parts.

** means easy broken part. and spare backup is suggested.

Please confirm the version of manual before placing the purchase order to guarantee that the item number of the spare part is in accordance with the real object.

Table 2-7 : Parts List (SDD-900U/500H~1200U/700H)

No.	Description	Part No.		
		900U/500H	900U/700H	1200U/700H
1	Castor (red)	YW03000400000	YW03000400000	YW03000400000
2	Bottom plate	-	-	-
3	Castor brake	YW03000400000	YW03000400000	YW03000400000
4	Condenser	YR30010400000	YR30010400000	YR30010400000
5	Front pole	-	-	-
6	Side plate	-	-	-
7	Blower *	BM30042000050	BM30042000050	BM30042000050
8	Side middle beam	-	-	-
9	Terminal board	YE61250000000	YE61250000000	YE61250000000
10	Capacitor	YE25001500000	YE25001500000	YE25001500000
11	Belt adjustor square block	BH10005000040	BH10005000040	BH10005000040
12	Gear motor	YM50512600000	YM50512600000	YM50512600000
13	Honeycomb bottom cover	BA40507000010	BA40507000010	BA40507000010
14	Rear middle beam	-	-	-
15	Regen. heater*	BH70501000050	BH70501000050	BH70501000050
16	Honeycomb	YW71443000100	YW71444000100	YW71444000100
17	Two-head screw	BH10543000010	BH10554500010	BH10554500010
18	Microswitch *	YE14152400000	YE14152400000	YE14152400000
19	Fixed seat of Microswitch (left smaller one)	YR40000100300	YR40000100300	YR40000100300
20	Fixed seat of Microswitch (right bigger one)	YR40000100200	YR40000100200	YR40000100200
21	Honeycomb upper cover	BA40507000110	BA40507000110	BA40507000110
22	Rear pole	-	-	-
23	Side beam	-	-	-
24	Water distributor	-	-	-
25	Rear middle beam	-	-	-
26	Rear fixing beam	-	-	-
27	Rear plate	-	-	-
28	Spring	YW01180300000	YW01180300000	YW01180300000
29	Top cover	-	-	-
30	Flange	-	-	-
31	Process heater*	BH70751800150	BH70902100150	BH70902100150
32	Outer fastener	-	-	-
33	Outer hopper cone	-	-	-

No.	Description	Part No.		
		900U/500H	900U/700H	1200U/700H
34	Material hopper	-	-	-
35	Hopper tank cover	-	-	-
36	Down-blowing pipe	-	-	-
37	Hopper top	-	-	-
38	Door frame	-	-	-
39	Sight glass window	-	-	-
40	Butterfly nut	YW09051600000	YW09051600000	YW09051600000
41	Stand plate	-	-	-
42	Stand fixer	-	-	-
43	Castor fixer	-	-	-
44	Control box	BH34905000250	BH34907000150	BH34120000150
45	Upper door plate	-	-	-
46	Door lock	YW00000600000	YW00000600000	YW00000600000
47	Control panel	YR01003000200	YR01003000200	YR01003000200
48	Main power supply switch*	YE40601500000	YE40601500000	YE40601500000
49	Lower door plate	-	-	-
50	Butterfly nut	YW09051600000	YW09051600000	YW09051600000
51	Filter cover	-	-	-
52	ADC18 filter**	YW03000200000	YW03000200000	YW03000200000
53	Filter**	YR50241400000	YR50241400000	YR50241400000
54	Hinge	YW06203400000	YW06203400000	YW06203400000
55	Motor *	YM30072900000	YM30072900000	YM30072900000
56	Anti-dust net	YR40120300000	YR40120300000	YR40120300000
57	Front middle beam	-	-	-
58	Transmission belt**	YR00205800000	YR00205800000	YR00205800000
59	Cooling fan**	YM60121200400	YM60121200400	YM60121200400

* means possible broken parts.

** means easy broken part. and spare backup is suggested.

Please confirm the version of manual before placing the purchase order to guarantee that the item number of the spare part is in accordance with the real object.

2.7.4 Pipe Heaters

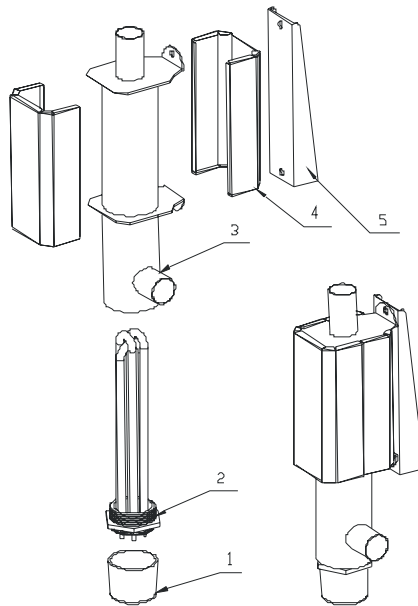

Names of Parts :

- | | | |
|-------------------------|----------------|-------------------|
| 1. Electric wood cover | 2. Pipe heater | 3. Heating bucket |
| 4. Outer covering board | 5. Fixer | |

Picture 2-5 : Pipe Heaters

2.7.5 Honeycomb Rotor

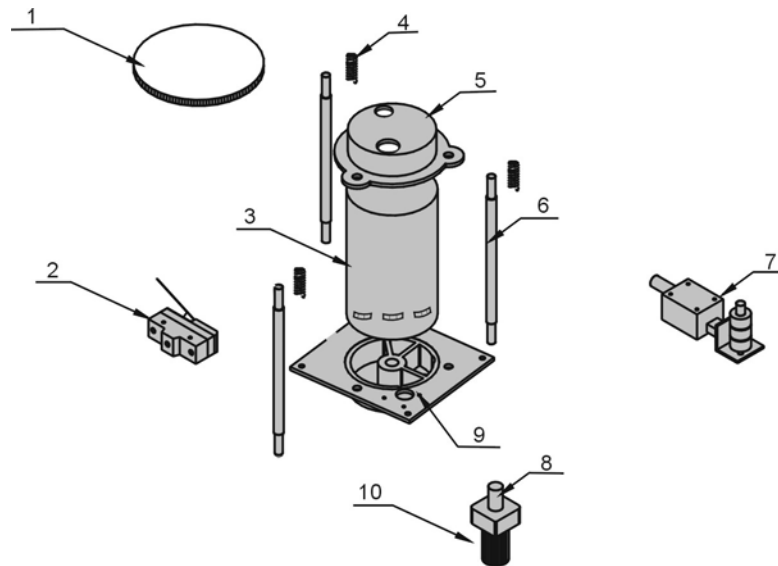

Names of Parts :

- | | | |
|---------------------------|-----------------------|-----------------------------|
| 1. Transmission belt | 2. Micro-switch | 3. Honeycomb rotor |
| 4. Spring | 5. Rotor top cover | 6. Double-headed screw bolt |
| 7. Belt tension regulator | 8. Transmission wheel | |
| 9. Rotor bottom cover | 10. Gearmotor | |

Picture 2-6 : Honeycomb Rotor

Table 2-9 : Electrical Diagram 2

No. Model	⓵	⓶	⓷	⓸	⓹	⓺	⓻	⓼	⓽	⓾
SCD-20U/30H	1-1.6	1.2	0.2	1.1	2.5	3.0	4.5	2.5	3.0	4.5
SCD-40U/30H	1-1.6	1.2	0.2	1.1	2.5	3.0	4.5	2.5	3.0	4.5
SCD-40U/50H	1-1.6	1.2	0.2	1.1	2.5	3.9	5.8	2.5	3.0	4.5
SCD-80U/50H	1-1.6	1.2	0.2	1.1	2.5	3.9	5.8	2.5	3.0	4.5
SCD-120U/80H	1-1.6	1.2	0.2	1.1	2.5	6.0	9.0	2.5	3.0	4.5
SCD-160U/80H	1-1.6	1.2	0.2	1.1	2.5	6.0	9.0	2.5	3.0	4.5
SCD-160U/120H	1-1.6	1.2	0.2	1.1	2.5	6.0	9.0	2.5	3.5	4.5
SCD-230U/120H	1-1.6	1.2	0.2	1.1	2.5	6.0	9.0	2.5	3.0	4.5
SCD-230U/150H	1-1.6	1.3	0.4	1.2	2.5	7.2	10.8	2.5	4.0	6.0
SCD-300U/150H	1-1.6	1.3	0.4	1.2	2.5	7.2	10.8	2.5	4.0	6.0
SCD-300U/200H	1-1.6	1.3	0.4	1.2	4.0	12.0	18.0	2.5	4.0	6.0
SCD-450U/200H	1-1.6	1.3	0.4	1.2	4.0	12.0	18.0	2.5	4.0	6.0
SCD-450U/300H	2-3.2	2.5	0.75	2.3	6.0	15.0	22.5	2.5	7.2	10.8
SCD-600U/300H	2-3.2	2.5	0.75	2.3	6.0	15.0	22.5	2.5	7.2	10.8
SCD-600U/400H	2-3.2	2.5	0.75	2.3	6.0	18.0	27.0	2.5	7.2	10.8
SCD-750U/400H	2-3.2	2.5	0.75	2.3	6.0	18.0	27.0	2.5	7.2	10.8
SCD-750U/500H	3.2-5	4.3	1.5	3.9	4.0	10.5×2	15.75	4.0	10.0	15.0
SCD-900U/500H	3.2-5	4.3	1.5	3.9	4.0	10.5×2	15.75	4.0	10.0	15.0
SCD-900U/700H	3.2-5	4.3	1.5	3.9	4.0	12×2	18.0	4.0	10.0	15.0
SCD-1200U/700H	3.2-5	4.3	1.5	3.9	4.0	12×2	18.0	4.0	10.0	15.0

- ⓵ Regenerative blower loader ⓶ Regenerative blower loader set ⓷ Regenerative blower power
- ⓸ Regenerative blower current ⓹ Drying heater wire dia. ⓺ Drying heater power
- ⓻ Drying heater current ⓼ Regenerative heater wire dia. ⓽ Regenerative heater power
- ⓾ Regenerative heater current

2.8.2 Main Circuit (PCB)

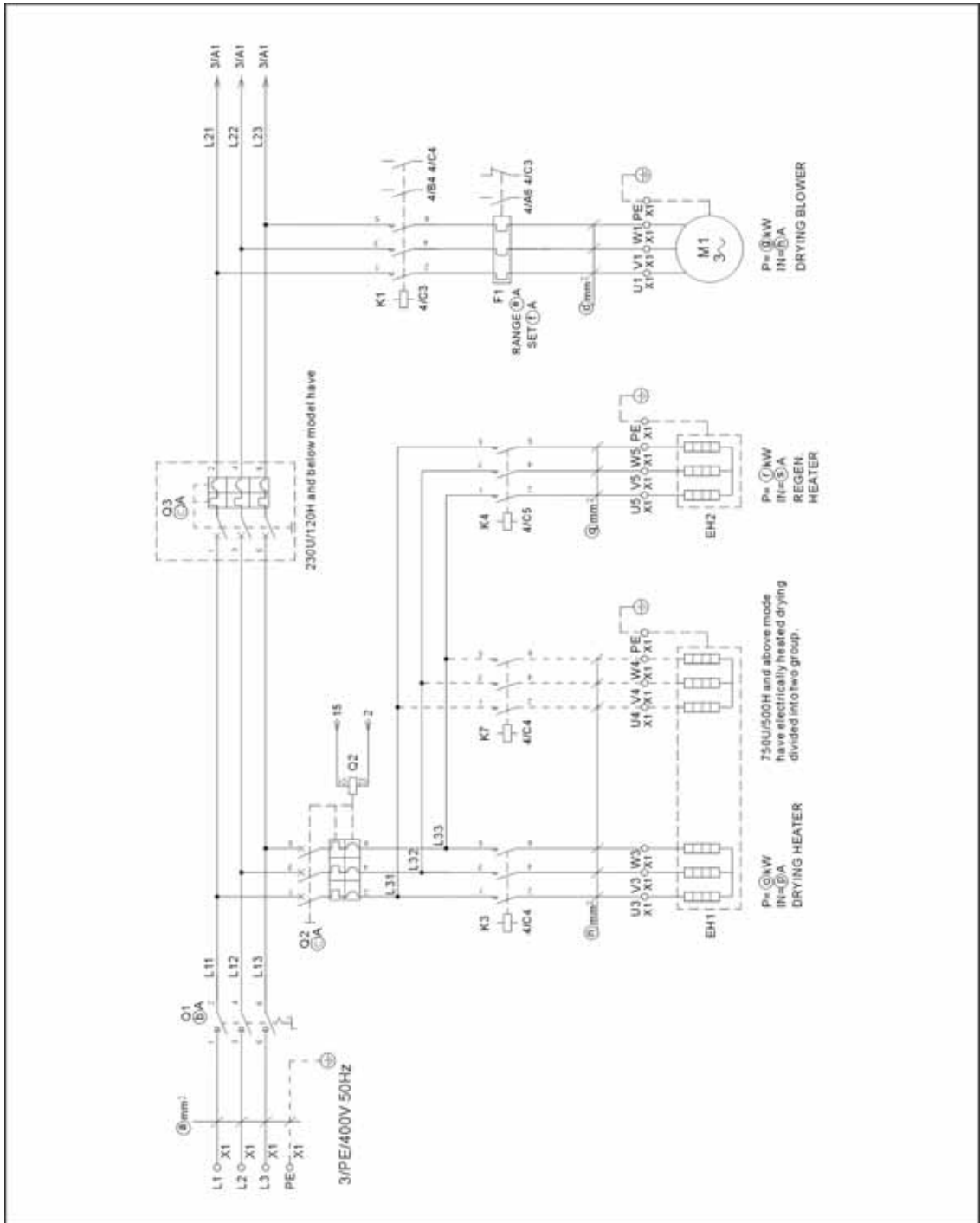

Picture 2-7 : Main Circuit 1 (PCB)

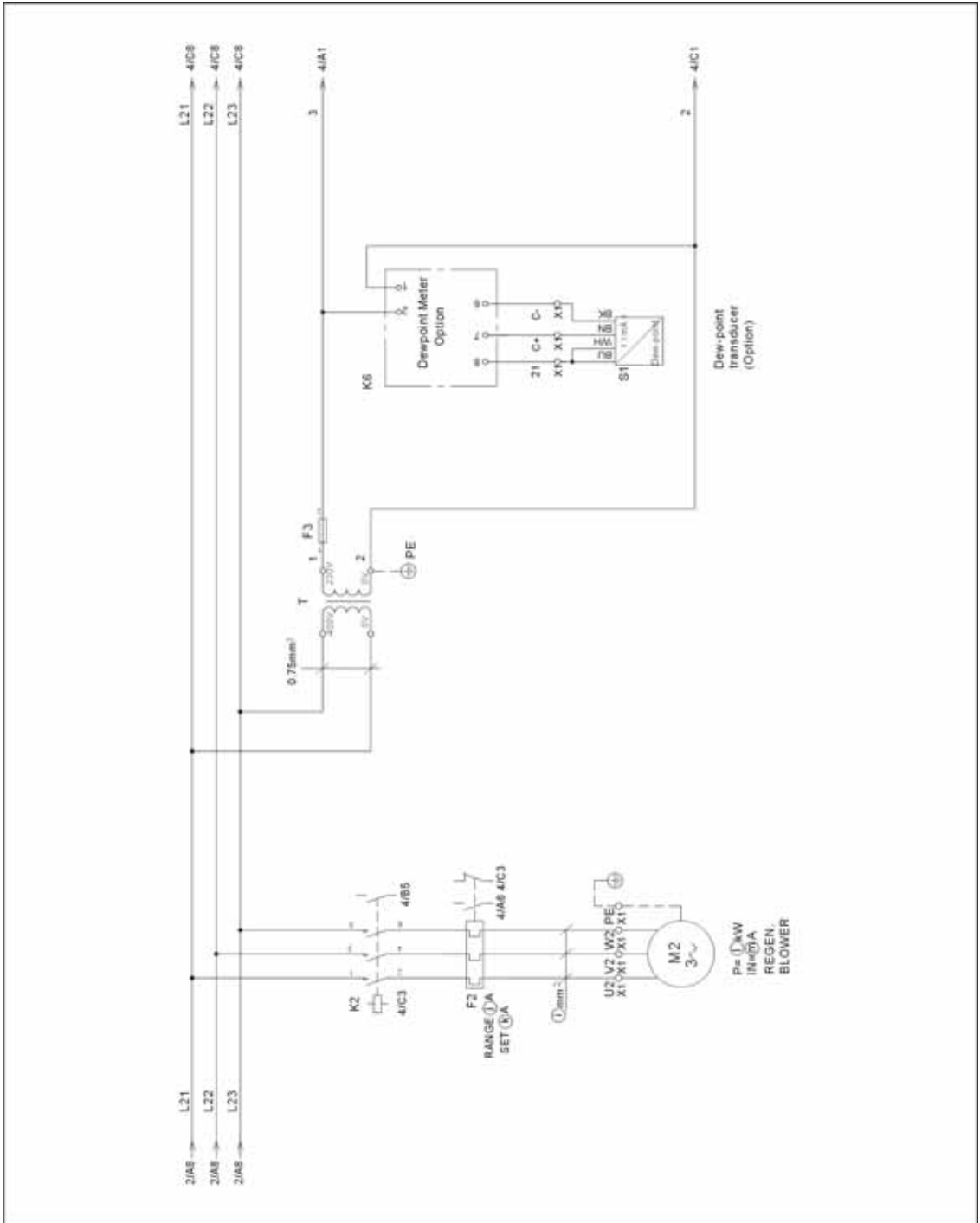

Picture 2-8 : Main Circuit 2(PCB)

2.8.3 Control Circuit (PCB)

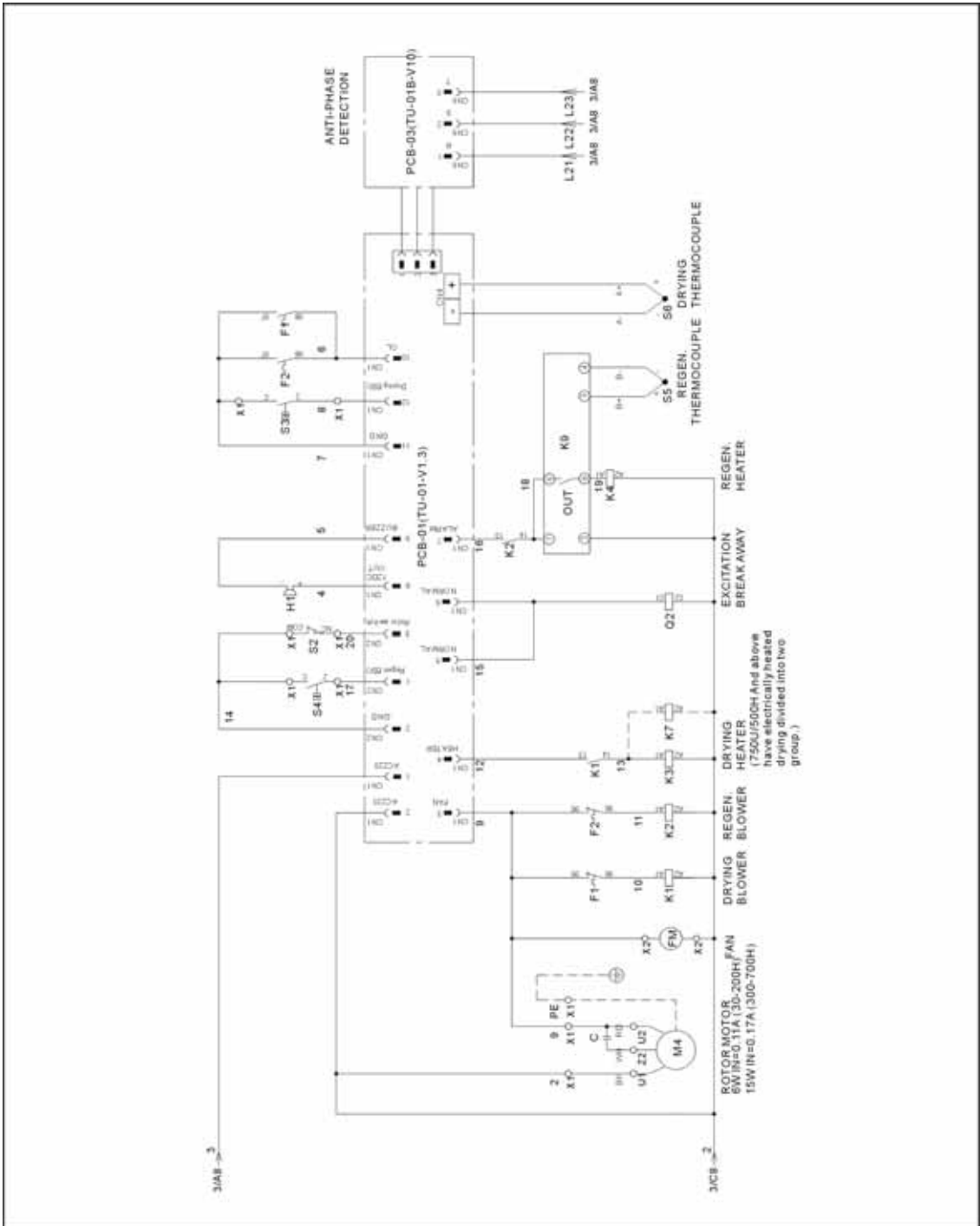

Picture 2-9 : Control Circuit (PCB)

2.8.4 Thermocouple Wiring Diagram (PCB)

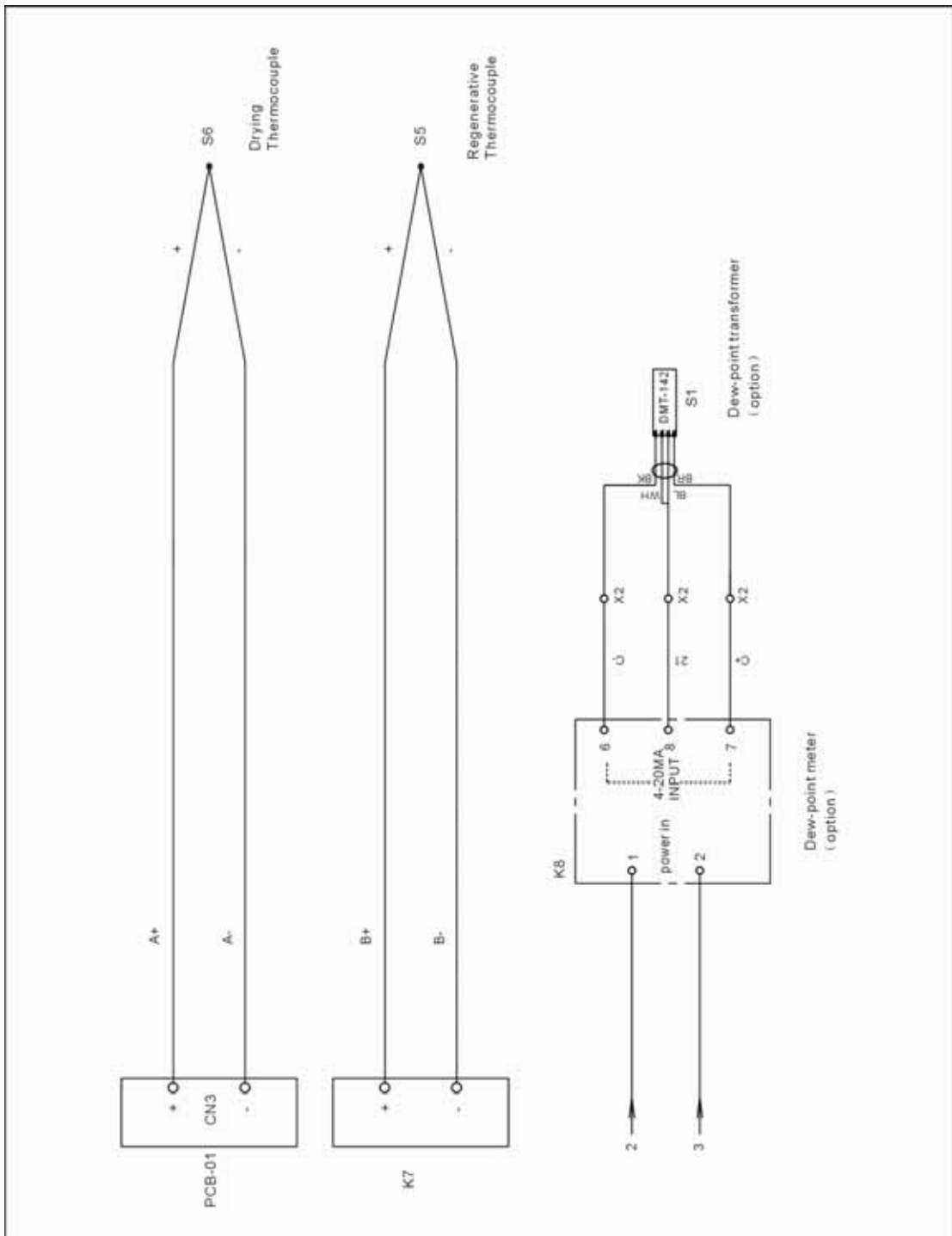

Picture 2-10 : Thermocouple Wiring Diagram (PCB)

2.8.5 Components Layout (PCB)

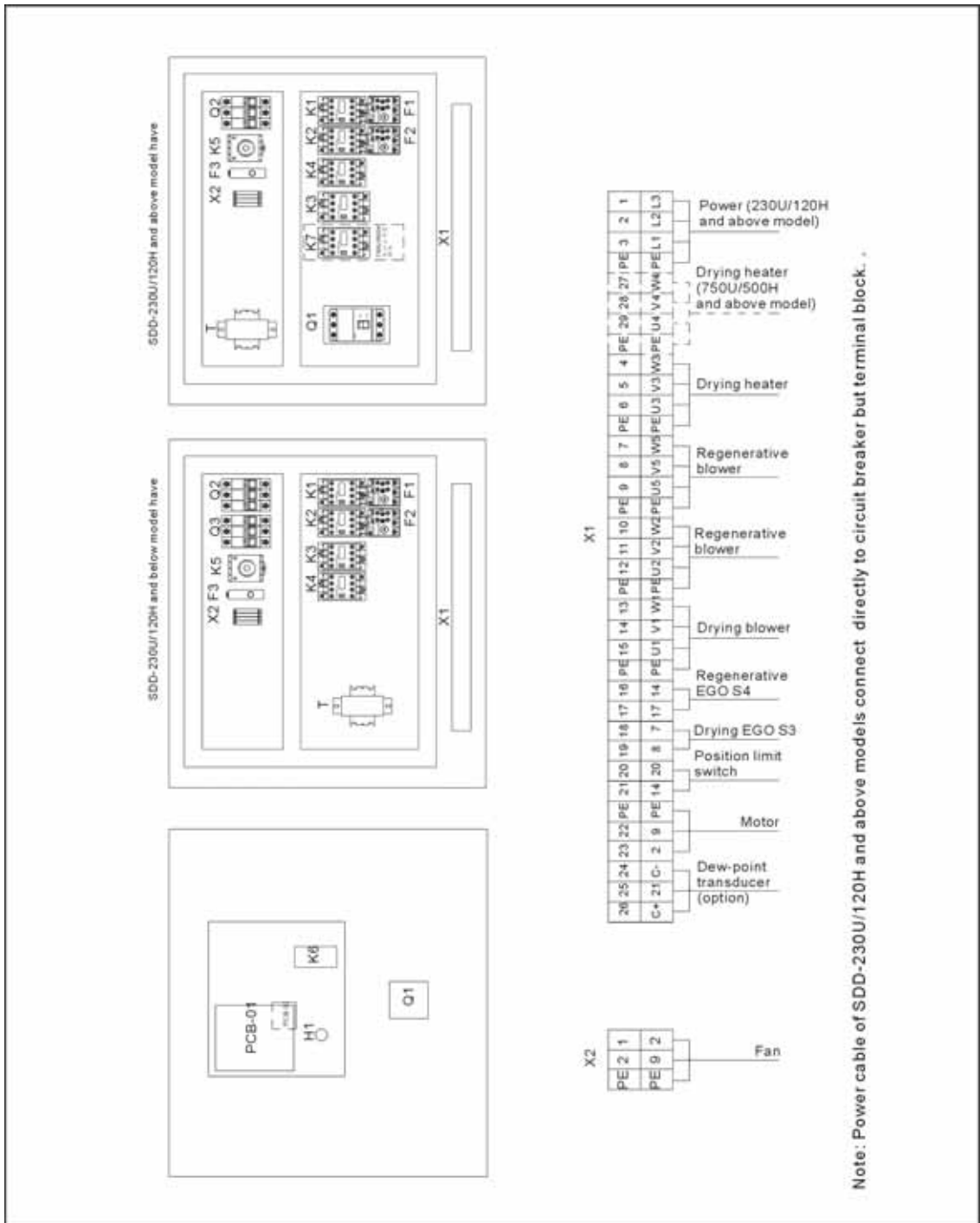

Picture 2-11 : Components Layout (PCB)

2.8.6 Electrical Components List (PCB)

Table 2-10 : Electrical Components List (PCB) (SDD-20U/40U-30H)

No.	Symbol	Name	Specifications	Part No.
1	Q1	Main switch*	16A	YE10200300000
2	Q2	Circuit breakers	16A	YE40601600000
3	-	Excitation break away	220VA-240VA	YE40000900000
4	Q3	Circuit breakers*	5A	YE40603000000
5	K1	Contactors**	230V 50Hz	YE00301000000
6	K2	Contactors**	230V 50Hz	YE00301000000
7	K3	Contactors**	230V 50Hz	YE00300000000
8	K4	Contactors**	230V 50Hz	YE00300000000
9	K5	Temperature controller	230V 50Hz	YE85050400000
10	PCB-01	PCB*	-	-
11	PCB-02	PCB	-	-
12	K6	Dew-point meter	230V 50/60Hz	YE85122000100
13	S1	Dew-point transducer	POWER=24VDC OUT=4~20mA	YE15041200000
14	F1 F2	Overload relay	1~1.6A	YE01011600000
15	F3	Fuse**	2A	YE41001000000
16	S2	Limit switch*	250V 5(4)A	YE14511100000
17	S3	Overheat protector*	250V 5(4)A	YE21503000400
18	S4	Overheat protector*	250V 5(4)A	YE68025300100
19	S5 S6	Thermocouple	K	BE90802000050
20	H1	Buzzer	24VDC	YE84002700000
21	T	Transformer	IN=400V OUT=230V 500mA	YE70402300800
22	X1	Terminal board	32A 690V	YE61250040000
23	X1	Terminal board	-	YE61253500000
24	X2	Terminal board	32A 690V	YE61250040000
25	-	-	-	YE61253500000
26	FM	Fan	220V-240VAC 40W	YM60121200400
27	M1	Blower**	220-240V/380-415V 0.2kW	-
28	M2	Blower**	220-240V/380-415V 0.2kW	-
29	M3	Motor**	200-240VAC 0.006kW	-
30	EH1	Heater**	220-240V/380-415V 3.0kW	-
31	EH2	Heater**	220-240V/380-415V 3.0kW	-

* means possible broken parts.

** means easy broken part. and spare backup is suggested.

Please confirm the version of manual before placing the purchase order to guarantee that the item number of the spare part is in accordance with the real object.

Table 2-11 : Electrical Components List (PCB) (SDD-40U/80U-50H)

No.	Symbol	Name	Specifications	Part No.
1	Q1	Main switch*	16A	YE10200300000
2	Q2	Circuit breakers	16A	YE40601600000
3	-	Excitation break away	220VA-240VA	YE40000900000
4	Q3	Circuit breakers*	5A	YE40603000000
5	K1	Contactors**	230V 50Hz	YE00301000000
6	K2	Contactors**	230V 50Hz	YE00301000000
7	K3	Contactors**	230V 50Hz	YE00300000000
8	K4	Contactors**	230V 50Hz	YE00300000000
9	K5	Temperature controller	230V 50Hz	YE85050400000
10	PCB-01	PCB*	-	-
11	PCB-02	PCB	-	-
12	K6	Dew-point meter	230V 50/60Hz	YE85122000100
13	S1	Dew-point transducer	POWER=24VDC OUT=4~20mA	YE15041200000
14	F1 F2	Overload relay	1~1.6A	YE01011600000
15	F3	Fuse**	2A	YE41001000000
16	S2	Limit switch*	250V 5(4)A	YE14511100000
17	S3	Overheat protector*	250V 5(4)A	YE21503000400
18	S4	Overheat protector*	250V 5(4)A	YE68025300100
19	S5 S6	Thermocouple	K	BE90802000050
20	H1	Buzzer	24VDC	YE84002700000
21	T	Transformer	IN=400V OUT=230V 500mA	YE70402300800
22	X1	Terminal board	32A 690V	YE61250040000
23	X1	Terminal board	-	YE61253500000
24	X2	Terminal board	32A 690V	YE61250040000
25	-	-	-	YE61253500000
26	FM	Fan	220V-240VAC 40W	YM60121200400
27	M1	Blower**	220-240V/380-415V 0.4kW	-
28	M2	Blower**	220-240V/380-415V 0.2kW	-
29	M3	Motor**	200-240VAC 0.006kW	-
30	EH1	Heater**	220-240V/380-415V 3.9kW	-
31	EH2	Heater**	220-240V/380-415V 3.0kW	-

* means possible broken parts.

** means easy broken part. and spare backup is suggested.

Please confirm the version of manual before placing the purchase order to guarantee that the item number of the spare part is in accordance with the real object.

Table 2-12 : Electrical Components List (PCB) (SDD-120U/160U-80H)

No.	Symbol	Name	Specifications	Part No.
1	Q1	Main switch*	25A	YE10200300000
2	Q2	Circuit breakers	20A	YE40602000100
3	-	Excitation break away	220VA-240VA	YE40000900000
4	Q3	Circuit breakers*	10A	YE40603000000
5	K1	Contactors**	230V 50Hz	YE00301000000
6	K2	Contactors**	230V 50Hz	YE00301000000
7	K3	Contactors**	230V 50Hz	YE00300000000
8	K4	Contactors**	230V 50Hz	YE00300000000
9	K5	Temperature controller	230V 50Hz	YE85050400000
10	PCB-01	PCB*	-	-
11	PCB-02	PCB	-	-
12	K6	Dew-point meter	230V 50/60Hz	YE85122000100
13	S1	Dew-point transducer	POWER=24VDC OUT=4~20mA	YE15041200000
14	F1	Overload relay	2~3.2A	YE01023200000
15	F2	Overload relay	1~1.6A	YE01011600000
16	F3	Fuse**	2A	YE41001000000
17	S2	Limit switch*	250V 5(4)A	YE14511100000
18	S3	Overheat protector*	250V 5(4)A	YE21503000400
19	S4	Overheat protector*	250V 5(4)A	YE68025300100
20	S5 S6	Thermocouple	K	BE90802000050
21	H1	Buzzer	24VDC	YE84002700000
22	T	Transformer	IN=400V OUT=230V 500mA	YE70402300800
23	X1	Terminal board	41A 690V	YE61040000000
24	-	Terminal board	-	YE61043500000
25	-	Terminal board	32A 690V	YE61250040000
26	X1	Terminal board	-	YE61253500000
27	X2	Terminal board	32A 690V	YE61250040000
28	-	Terminal board	-	YE61253500000
29	FM	Fan	220V-240VAC 40W	YM60121200400
30	M1	Blower**	220-240V/380-415V 0.75kW	-
31	M2	Blowe**	220-240V/380-415V 0.2kW	-
32	M3	Motor**	200-240VAC 0.006kW	-
33	EH1	Heater**	220-240V/380-415V 6.0kW	-
34	EH2	Heater**	220-240V/380-415V 3.0kW	-

* means possible broken parts. ** means easy broken part. and spare backup is suggested. Please confirm the version of manual before placing the purchase order to guarantee that the item number of the spare part is in accordance with the real object.

Table 2-13 : Electrical Components List (PCB) (SDD-160U/230U-120H)

No.	Symbol	Name	Specifications	Part No.
1	Q1	Main switch*	25A	YE10200300000
2	Q2	Circuit breakers	20A	YE40602000100
3	-	Excitation break away	220VA-240VA	YE40000900000
4	Q3	Circuit breakers*	10A	YE40603000000
5	K1	Contactors**	230V 50Hz	YE00301000000
6	K2	Contactors**	230V 50Hz	YE00301000000
7	K3	Contactors**	230V 50Hz	YE00300000000
8	K4	Contactors**	230V 50Hz	YE00300000000
9	K5	Temperature controller	230V 50Hz	YE85050400000
10	PCB-01	PCB*	-	-
11	PCB-02	PCB	-	-
12	K6	Dew-point meter	230V 50/60Hz	YE85122000100
13	S1	Dew-point transducer	POWER=24VDC OUT=4~20mA	YE15041200000
14	F1	Overload relay	2~3.2A	YE01023200000
15	F2	Overload relay	1~1.6A	YE01011600000
16	F3	Fuse**	2A	YE41001000000
17	S2	Limit switch*	250V 5(4)A	YE14511100000
18	S3	Overheat protector*	250V 5(4)A	YE21503000400
19	S4	Overheat protector*	250V 5(4)A	YE68025300100
20	S5 S6	Thermocouple	K	BE90802000050
21	H1	Buzzer	24VDC	YE84002700000
22	T	Transformer	IN=400V OUT=230V 500mA	YE70402300800
23	X1	Terminal board	41A 690V	YE61040000000
24	-	Terminal board	-	YE61043500000
25	-	Terminal board	32A 690V	YE61250040000
26	X1	Terminal board	-	YE61253500000
27	X2	Terminal board	32A 690V	YE61250040000
28	-	Terminal board	-	YE61253500000
29	FM	Fan	220V-240VAC 40W	YM60121200400
30	M1	Blower**	220-240V/380-415V 0.75kW	-
31	M2	Blower**	220-240V/380-415V 0.2kW	-
32	M3	Motor**	200-240VAC 0.006kW	-
33	EH1	Heater**	220-240V/380-415V 6.0kW	-
34	EH2	Heater**	220-240V/380-415V 3.0kW	-

* means possible broken parts. ** means easy broken part. and spare backup is suggested. Please confirm the version of manual before placing the purchase order to guarantee that the item number of the spare part is in accordance with the real object.

Table 2-14 : Electrical Components List (PCB) (SDD-230U/300U-150H)

No.	Symbol	Name	Specifications	Part No.
1	Q1	Main switch*	40A	YE41104000000
2	Q2	Circuit breakers	25A 400V 3P	YE40632500000
3	-	Excitation break away	220VAC-240VAC	YE40000900000
4	K1	Circuit breakers*	230V 50Hz	YE00301000000
5	K2	Contactors**	230V 50Hz	YE00301000000
6	K3	Contactors**	230V 50Hz	YE00320000000
7	K4	Contactors**	230V 50Hz	YE00300000000
8	K5	Contactors**	230V 50Hz	YE85050400000
9	PCB-01	Temperature controller	-	YE80001500000
10	PCB-02	PCB*	-	YE80010200000
11	K6	PCB	230V 50/60Hz	YE85122000100
12	S1	Dew-point meter	POWER=24VDC OUT=4~20mA	YE15041200000
13	F1	Dew-point transducer	3.2~5A	YE01032500000
14	F2	Overload relay	1~1.6A	YE01011600000
15	F3	Overload relay	2A	YE41001000000
16	S2	Fuse**	250V 5(4)A	YE14511100000
17	S3	Limit switch*	250V 5(4)A	YE21503000400
18	S4	Overheat protector*	250V 5(4)A	YE68025300100
19	S5 S6	Thermocouple	K	BE90802000050
20	H1	Buzzer	24VDC	YE84002700000
21	T	Transformer	IN=400V OUT=230V 500mA	YE70402300800
22	X1	Terminal board	-	YE61063500000
23	X1	Terminal board	32A 690V	YE61250000000
24	-	Terminal board	-	YE61253500000
25	X2	Terminal board	32A 690V	YE61250000000
26	-	Terminal board	-	YE61253500000
27	FM	Fan	220V-240VAC 40W	YM60121200400
28	M1	Blower**	220-240V/380-415V 1.5kW	-
29	M2	Blower**	220-240V/380-415V 0.4kW	-
30	M3	Motor**	200-240VAC 0.006kW	-
31	EH1	Heater**	220-240V/380-415V 7.2kW	-
32	EH2	Heater**	220-240V/380-415V 4kW	-

* means possible broken parts.

** means easy broken part. and spare backup is suggested.

Please confirm the version of manual before placing the purchase order to guarantee that the item number of the spare part is in accordance with the real object.

Table 2-15 : Electrical Components List (PCB) (SDD-300U/450U-200H)

No.	Symbol	Name	Specifications	Part No.
1	Q1	Main switch*	40A	YE41104000000
2	Q2	Circuit breakers	25A 400V 3P	YE40632500000
3	-	Excitation break away	220VAC-240VAC	YE40000900000
4	K1	Circuit breakers*	230V 50Hz	YE00301000000
5	K2	Contactors**	230V 50Hz	YE00301000000
6	K3	Contactors**	230V 50Hz	YE00320000000
7	K4	Contactors**	230V 50Hz	YE00300000000
8	K5	Contactors**	230V 50Hz	YE85050400000
9	PCB-01	Temperature controller	-	YE80001500000
10	PCB-02	PCB*	-	YE80010200000
11	K6	PCB	230V 50/60Hz	YE85122000100
12	S1	Dew-point meter	POWER=24VDC OUT=4~20mA	YE15041200000
13	F1	Dew-point transducer	3.2~5A	YE01032500000
14	F2	Overload relay	1~1.6A	YE01011600000
15	F3	Overload relay	2A	YE41001000000
16	S2	Fuse**	250V 5(4)A	YE14511100000
17	S3	Limit switch*	250V 5(4)A	YE21503000400
18	S4	Overheat protector*	250V 5(4)A	YE68025300100
19	S5 S6	Thermocouple	K	BE90802000050
20	H1	Buzzer	24VDC	YE84002700000
21	T	Transformer	IN=400V OUT=230V 500mA	YE70402300800
22	X1	Terminal board	-	YE61063500000
23	X1	Terminal board	32A 690V	YE61250000000
24	-	Terminal board	-	YE61253500000
25	X2	Terminal board	32A 690V	YE61250000000
26	-	Terminal board	-	YE61253500000
27	FM	Fan	220V-240VAC 40W	YM60121200400
28	M1	Blower**	220-240V/380-415V 1.5kW	-
29	M2	Blower**	220-240V/380-415V 0.4kW	-
30	M3	Motor**	200-240VAC 0.006kW	-
31	EH1	Heater**	220-240V/380-415V 7.2kW	-
32	EH2	Heater**	220-240V/380-415V 4kW	-

* means possible broken parts. ** means easy broken part. and spare backup is suggested. Please confirm the version of manual before placing the purchase order to guarantee that the item number of the spare part is in accordance with the real object.

Table 2-16 : Electrical Components List (PCB) (SDD-450U/600U-300H)

No.	Symbol	Name	Specifications	Part No.
1	Q1	Main switch*	60A	YE40636300000
2	Q2	Circuit breakers	40A 400V 3P	YE40634000000
3	-	Excitation break away	S9	YE40000900000
4	K1	Circuit breakers*	230V 50Hz	YE00301000000
5	K2	Contactors**	230V 50Hz	YE00301000000
6	K3	Contactors**	230V 50Hz	YE00340000000
7	K4	Contactors**	230V 50Hz	YE00320000000
8	K5	Contactors**	230V 50Hz	YE85050400000
9	PCB-01	Temperature controller	STC 43/44	YE80001500000
10	PCB-02	PCB*	-	YE80010200000
11	K6	PCB	230V 50/60Hz	YE85122000100
12	S1	Dew-point meter	POWER=24VDC OUT=4~20mA	YE15041200000
13	F1	Dew-point transducer	5~8A	YE01050800000
14	F2	Overload relay	2~3.2A	YE01023200000
15	F3	Overload relay	2A	YE41001000000
16	S2	Fuse**	250V 5(4)A	YE14511100000
17	S3	Limit switch*	250V 5(4)A	YE21503000400
18	S4	Overheat protector*	250V 5(4)A	YE68025300100
19	S5 S6	Thermocouple	K	BE90802000050
20	H1	Buzzer	24VDC	YE84002700000
21	T	Transformer	IN=400V OUT=230V 800mA	YE70402300900
22	X1	Terminal board	-	YE61163500000
23	X1	Terminal board	57A 690V	YE61060000000
24	-	Terminal board	-	YE61063500000
25	-	Terminal board	32A 690V	YE61250000000
26	-	Terminal board	-	YE61253500000
27	X2	Terminal board	32A 690V	YE61250000000
28	-	Terminal board	-	YE61253500000
29	FM	Fan	220V-240VAC 40W	YM60121200400
30	M1	Blower**	220-240V/380-415V 2.4kW	-
31	M2	Blower**	220-240V/380-415V 0.75kW	-
32	M3	Motor**	200-240VAC 0.015kW	-
33	EH1	Heater**	220-240V/380-415V 15kW	-
34	EH2	Heater**	220-240V/380-415V 7.2kW	-

* means possible broken parts. ** means easy broken part. and spare backup is suggested. Please confirm the version of manual before placing the purchase order to guarantee that the item number of the spare part is in accordance with the real object.

Table 2-17 : Electrical Components List (PCB) (SDD-600U/750U-400H)

No.	Symbol	Name	Specifications	Part No.
1	Q1	Main switch*	60A	YE40636300000
2	Q2	Circuit breakers	50A 400V 3P	YE40635000000
3	-	Excitation break away	S9	YE40000900000
4	K1	Circuit breakers*	230V 50Hz	YE00301000000
5	K2	Contactors**	230V 50Hz	YE00301000000
6	K3	Contactors**	230V 50Hz	YE00340000000
7	K4	Contactors**	230V 50Hz	YE00320000000
8	K5	Contactors**	230V 50Hz	YE85050400000
9	PCB-01	Temperature controller	STC 43/44	YE80001500000
10	PCB-02	PCB*	-	YE80010200000
11	K6	PCB	230V 50/60Hz	YE85122000100
12	S1	Dew-point meter	POWER=24VDC OUT=4~20mA	YE15041200000
13	F1	Dew-point transducer	6.3~10A	YE01631000000
14	F2	Overload relay	2~3.2A	YE01023200000
15	F3	Overload relay	2A	YE41001000000
16	S2	Fuse**	250V 5(4)A	YE14511100000
17	S3	Limit switch*	250V 5(4)A	YE21503000400
18	S4	Overheat protector*	250V 5(4)A	YE68025300100
19	S5 S6	Thermocouple	K	BE90802000050
20	H1	Buzzer	24VDC	YE84002700000
21	T	Transformer	IN=400V OUT=230V 800mA	YE70402300900
22	X1	Terminal board	-	YE61163500000
23	X1	Terminal board	57A 690V	YE61060000000
24	-	Terminal board	-	YE61063500000
25	-	Terminal board	32A 690V	YE61250000000
26	-	Terminal board	-	YE61253500000
27	X2	Terminal board	32A 690V	YE61250000000
28	-	Terminal board	-	YE61253500000
29	FM	Fan	220V-240VAC 40W	YM60121200400
30	M1	Blower**	220-240V/380-415V 3.75kW	-
31	M2	Blower**	220-240V/380-415V 0.75kW	-
32	M3	Motor**	200-240VAC 0.015kW	-
33	EH1	Heater**	220-240V/380-415V 18kW	-
34	EH2	Heater**	220-240V/380-415V 7.2kW	-

* means possible broken parts. ** means easy broken part. and spare backup is suggested. Please confirm the version of manual before placing the purchase order to guarantee that the item number of the spare part is in accordance with the real object.

Table 2-18 : Electrical Components List (PCB) (SDD-750U/900U-500H)

No.	Symbol	Name	Specifications	Part No.
1	Q1	Main switch*	80A	YE41109000000
2	Q2	Circuit breakers	63A 400V 3P	YE40636300000
3	-	Excitation break away	S9	YE40000900000
4	K1	Circuit breakers*	230V 50Hz	YE00301000000
5	K2	Contactors**	230V 50Hz	YE00301000000
6	K3	Contactors**	230V 50Hz	YE00340000000
7	K4	Contactors**	230V 50Hz	YE00320000000
8	K5	Contactors**	230V 50Hz	YE85050400000
9	PCB-01	Temperature controller	STC 43/44	YE80001500000
10	PCB-02	PCB*	-	YE80010200000
11	K6	PCB	230V 50/60Hz	YE85122000100
12	S1	Dew-point meter	POWER=24VDC OUT=4~20mA	YE15041200000
13	F1	Dew-point transducer	10~16A	YE01101600100
14	F2	Overload relay	3.2~5A	YE01032500000
15	F3	Overload relay	2A	YE41001000000
16	S2	Fuse**	250V 5(4)A	YE14511100000
17	S3	Limit switch*	250V 5(4)A	YE21503000400
18	S4	Overheat protector*	250V 5(4)A	YE68025300100
19	S5 S6	Thermocouple	K	BE90802000050
20	H1	Buzzer	24VDC	YE84002700000
21	T	Transformer	IN=400V OUT=230V 800mA	YE70402300900
22	X1	Terminal board	-	YE61250040000
23	X1	Terminal board	41A 690V	YE61040000000
24	-	Terminal board	-	YE61043500000
25	-	Terminal board	32A 690V	YE61250040000
26	-	Terminal board	-	YE61253500000
27	X2	Terminal board	32A 690V	YE61250000000
28	-	Terminal board	-	YE61253500000
29	FM	Fan	220V-240VAC 40W	YM60121200400
30	M1	Blower**	220-240V/380-415V 5.5kW	-
31	M2	Blowe**	220-240V/380-415V 1.5kW	-
32	M3	Motor**	200-240VAC 0.015kW	-
33	EH1	Heater**	220-240V/380-415V 21kW	-
34	EH2	Heater**	220-240V/380-415V 10kW	-

* means possible broken parts. ** means easy broken part. and spare backup is suggested. Please confirm the version of manual before placing the purchase order to guarantee that the item number of the spare part is in accordance with the real object.

Table 2-19 : Electrical Components List (PCB) (SDD-900U/1200U-700H)

No.	Symbol	Name	Specifications	Part No.
1	Q1	Main switch*	100A	YE41110000000
2	Q2	Circuit breakers	63A 400V 3P	YE40636300000
3	-	Excitation break away	S9	YE40000900000
4	K1	Circuit breakers*	230V 50Hz	YE00301000000
5	K2	Contactors**	230V 50Hz	YE00301000000
6	K3	Contactors**	230V 50Hz	YE00340000000
7	K4	Contactors**	230V 50Hz	YE00320000000
8	K5	Contactors**	230V 50Hz	YE85050400000
9	PCB-01	Temperature controller	STC 43/44	YE80001500000
10	PCB-02	PCB*	-	YE80010200000
11	K6	PCB	230V 50/60Hz	YE85122000100
12	S1	Dew-point meter	POWER=24VDC OUT=4~20mA	YE15041200000
13	F1	Dew-point transducer	10~16A	YE01101600100
14	F2	Overload relay	3.2~5A	YE01032500000
15	F3	Overload relay	2A	YE41001000000
16	S2	Fuse**	250V 5(4)A	YE14511100000
17	S3	Limit switch*	250V 5(4)A	YE21503000400
18	S4	Overheat protector*	250V 5(4)A	YE68025300100
19	S5 S6	Thermocouple	K	BE90802000050
20	H1	Buzzer	24VDC	YE84002700000
21	T	Transformer	IN=400V OUT=230V 800mA	YE70402300900
22	X1	Terminal board	-	YE61250040000
23	X1	Terminal board	41A 690V	YE61040000000
24	-	Terminal board	-	YE61043500000
25	-	Terminal board	32A 690V	YE61250040000
26	-	Terminal board	-	YE61253500000
27	X2	Terminal board	32A 690V	YE61250000000
28	-	Terminal board	-	YE61253500000
29	FM	Fan	220V-240VAC 40W	YM60121200400
30	M1	Blower**	220-240V/380-415V 5.5kW	-
31	M2	Blower**	220-240V/380-415V 1.5kW	-
32	M3	Motor**	200-240VAC 0.015kW	-
33	EH1	Heater**	220-240V/380-415V 24kW	-
34	EH2	Heater**	220-240V/380-415V 10kW	-

* means possible broken parts. ** means easy broken part. and spare backup is suggested. Please confirm the version of manual before placing the purchase order to guarantee that the item number of the spare part is in accordance with the real object.

2.8.7 Main Circuit (PLC)

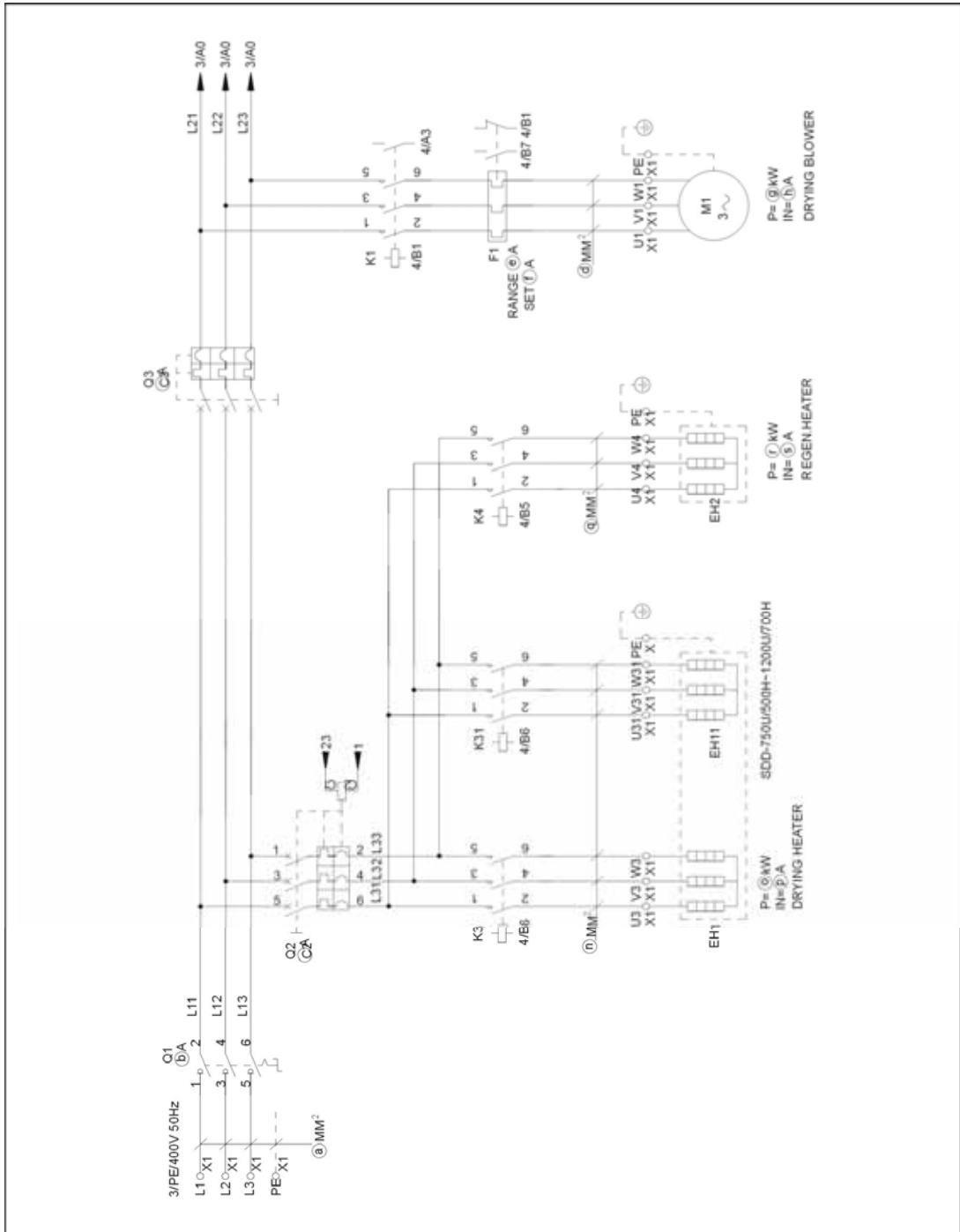

Picture 2-12 : Main Circuit 1 (PLC)

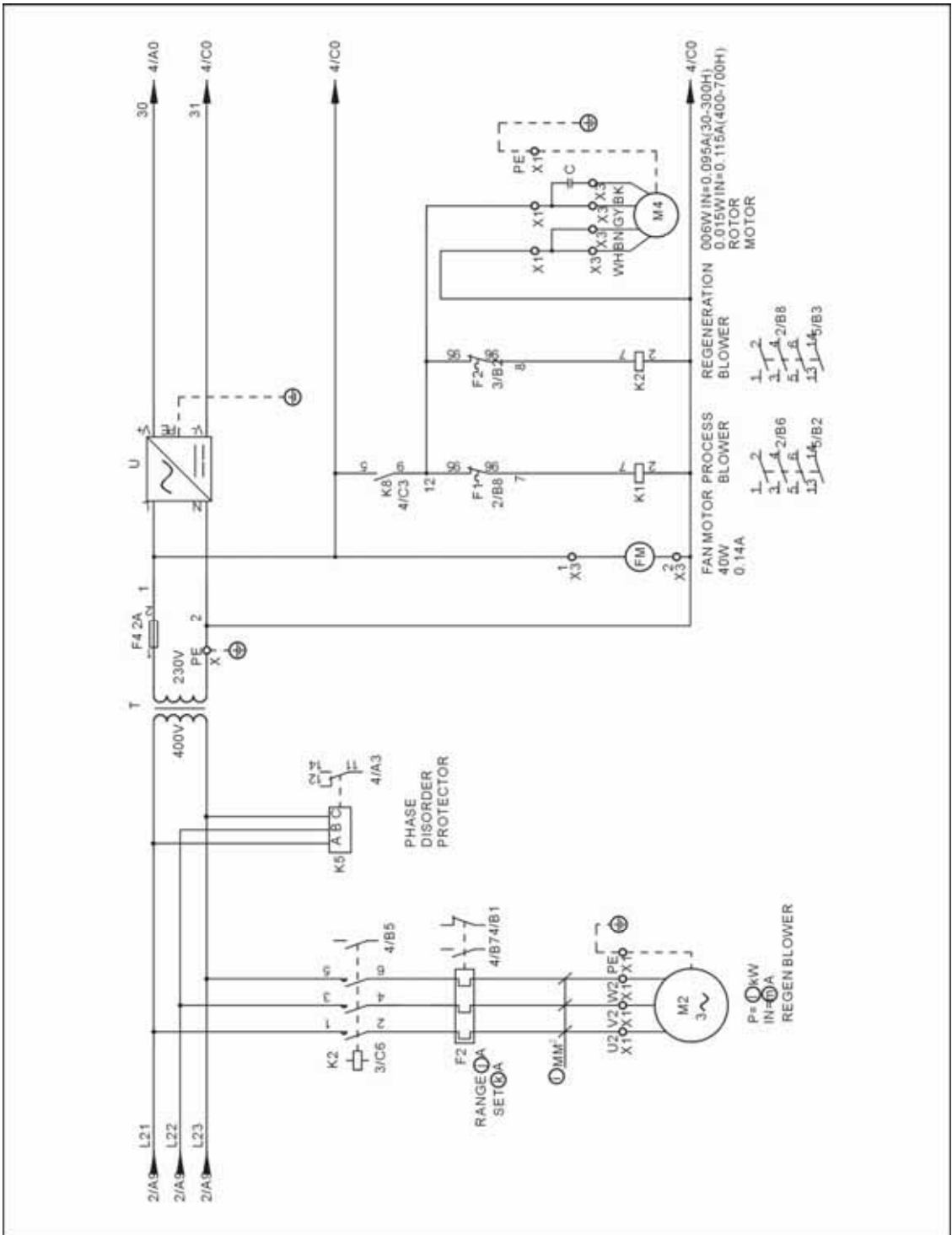

Picture 2-13 : Main Circuit 2 (PLC)

2.8.8 Control Circuit (PLC)

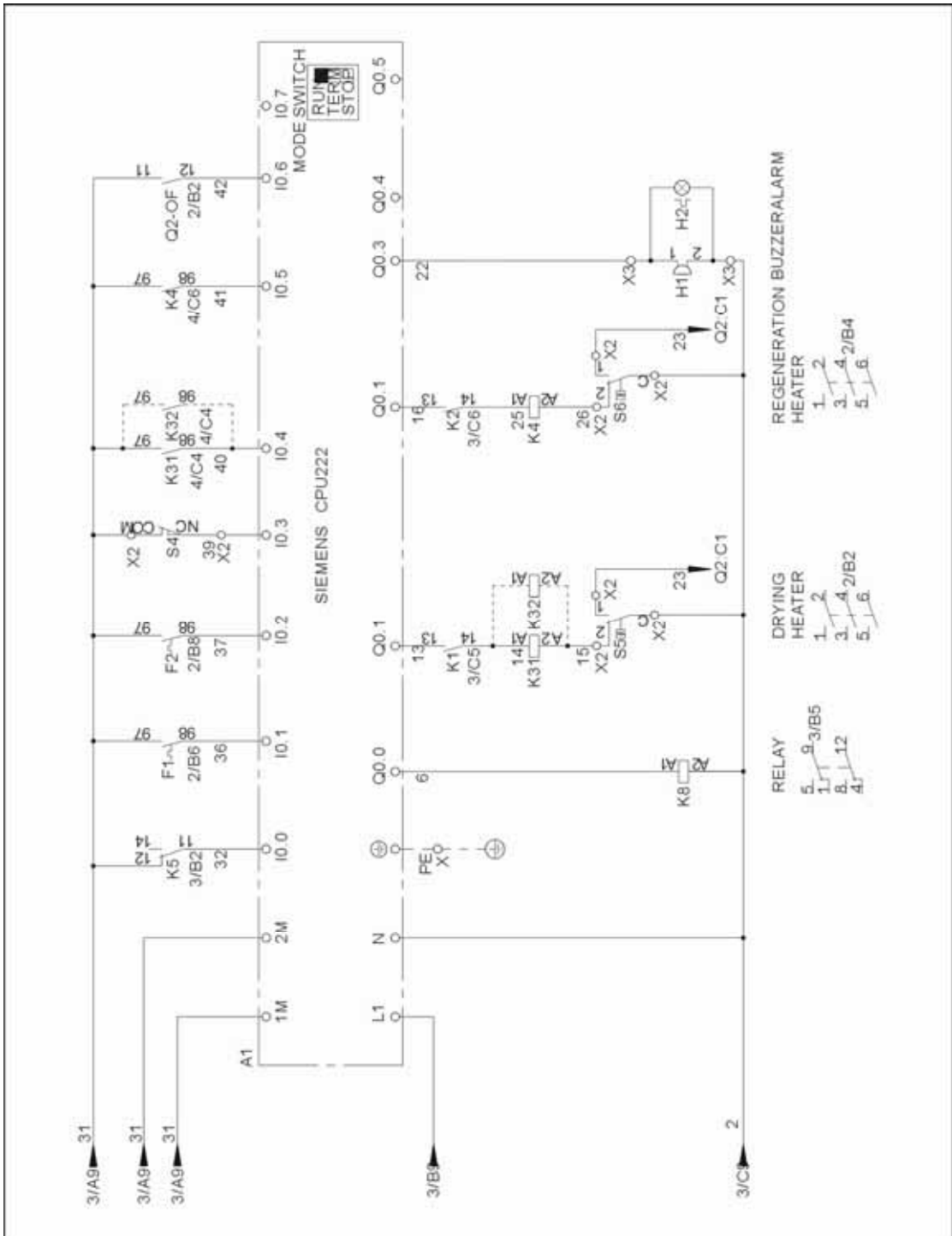

Picture 2-14 : Control Circuit (PLC)

2.8.9 Thermocouple Wiring Diagram (PLC)

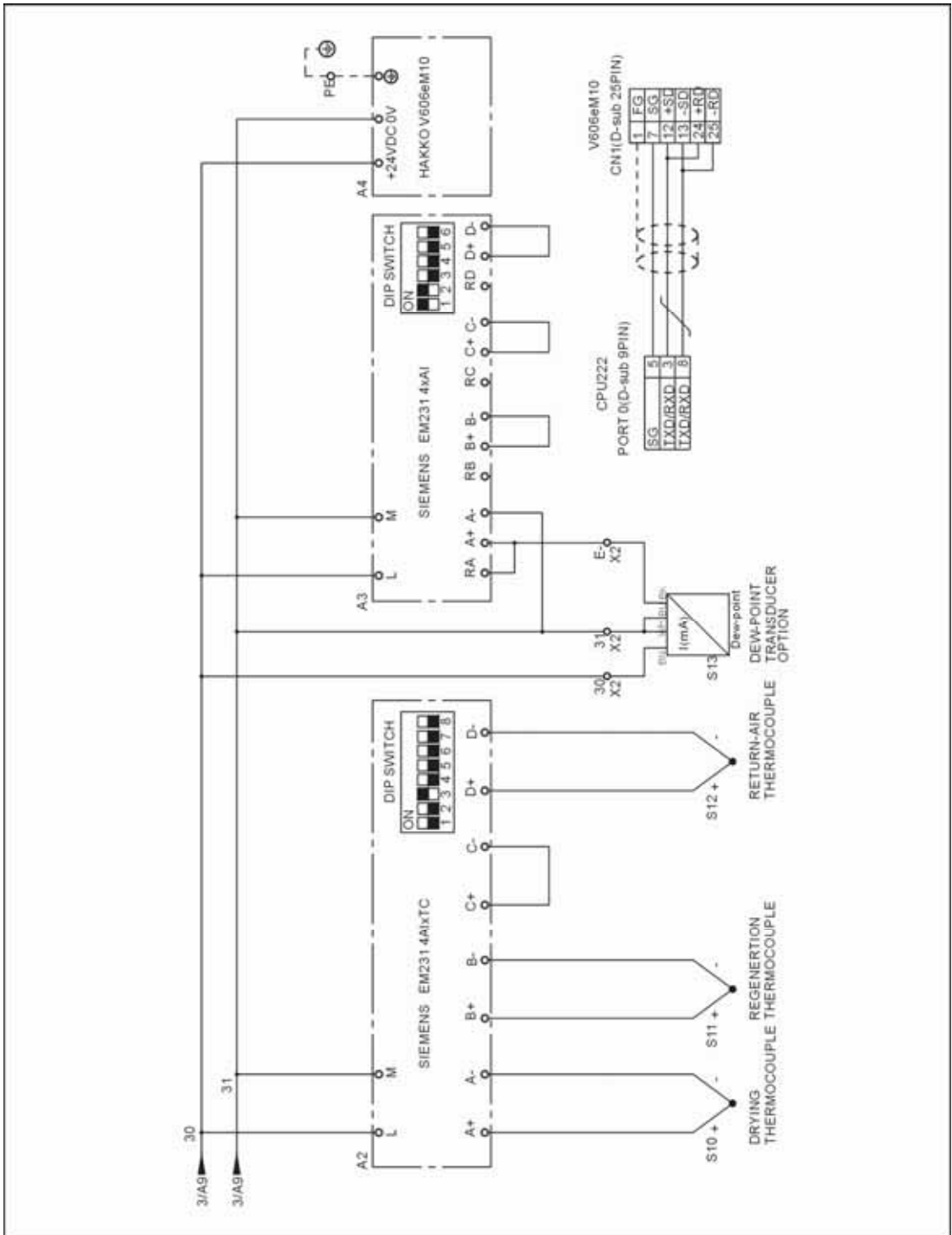

Picture 2-15 : Thermocouple Wiring Diagram (PLC)

2.8.10 Components Layout (PLC)

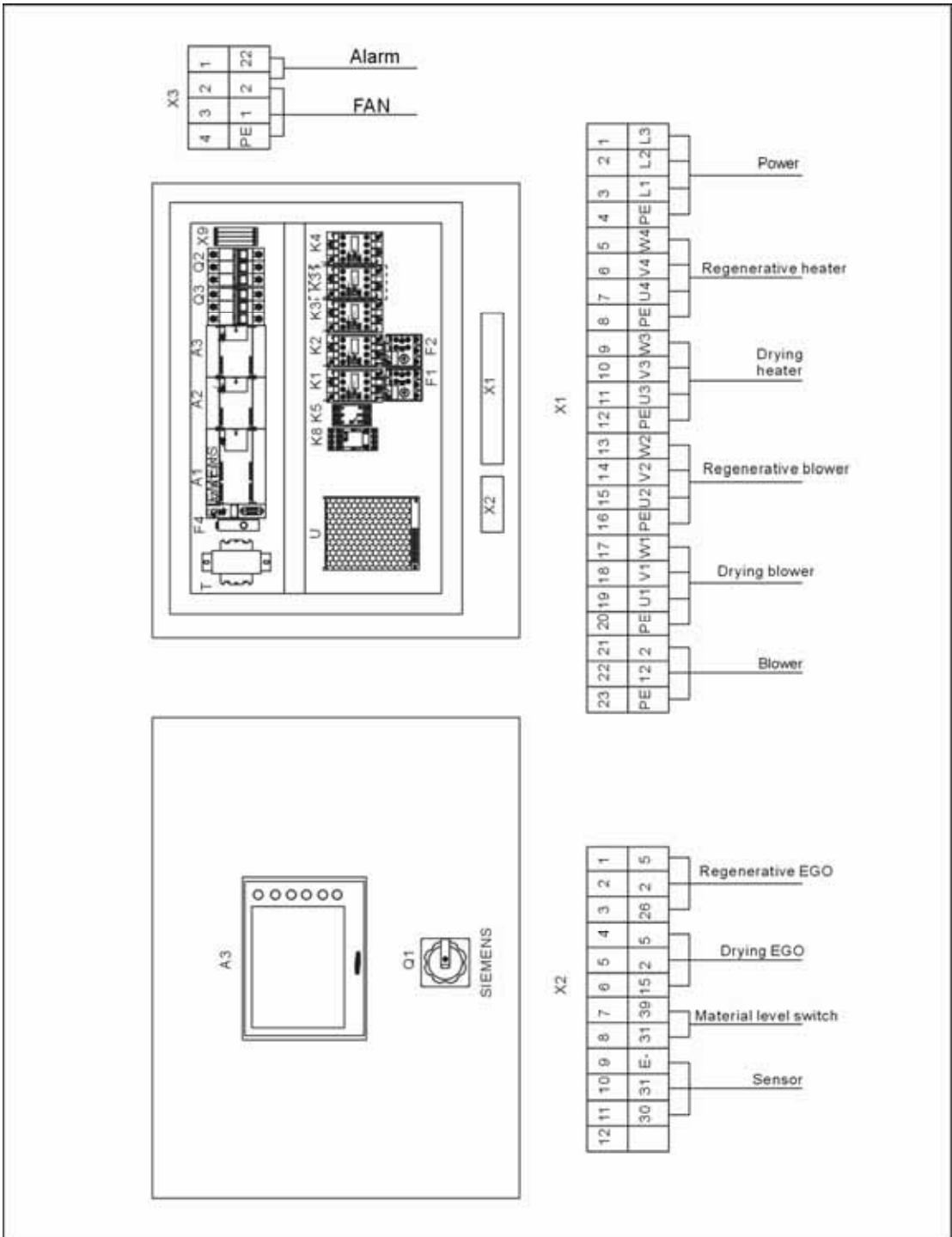

Picture 2-16 : Components Layout (PLC)

2.8.11 Electrical Components List (PLC)

Table 2-20 : Electrical Components List (PLC) (SDD-20U/30H)

No.	Symbol	Name	SDD-20U/30H	
			Specifications	Part No.
1	Q1	Main switch*	16A	YE10200300000
2	Q2	Circuit-breaker	15A	YE40000900000
3	Q3	Circuit-breaker*	5A	YE40601600000
4	K1	Contacto**	230VAC 50Hz	YE00301000000
5	K2	Contacto**	230VAC 50Hz	YE00301000000
6	K3	Contacto**	230VAC 50Hz	YE00301000000
7	K4	Contacto**	230VAC 50Hz	YE00301000000
8	K5	Phase protector	230VAC 50Hz	YE03103800000
9	K8	Relay	230VAC 50Hz 12A	YE03270700000
10	A1	PLC	100-230VAC 50/60Hz	YE81022400100
11	A2	Analog module	-	YE82023100100
12	A4	Human-machine interface	24VDC 0.4A	YE80211000000
13	A3	Analog module	-	YE82023100100
14	S13	Dew-point meter	POWER=24VDC OUT=4~20mA	YE15041200000
15	F1	Overload relay	1.25-2A	YE01063100000
16	F2	Overload relay	1.25-2A	YE01063100000
17	F4	Fuse*	2A Fuse	YE41001000000
18	S4	Limit switch*	250V~5(4)A	YE14152400000
19	S5 S6	Overheat protector*	250V~5(4)A	YE21503000000
20	S10 S11 S12	Thermocouple**	K	BE90802000050
21	U	DC power	OUT=DC24V 1.5A	YE71352400000
22	H1	Buzzer	60-250V AC/DC 5~35mA	YE84003500200
23	H2	Alarm indicate lamp	230VAC 50Hz	YE83305100300
24	T	Transformer**	IN=400V OUT=230V 500mA	YE70402300800
25	X1	Terminal board	32A 690V	YE61250000000
26	-	-	-	YE61253500000
27	X2	Terminal board	32A 690V	YE00300000000
28	X3	Terminal board	32A 690V	YE61250000000
29	-	-	-	YE61253500000
30	X4	Terminal board	32A 390V	YE61250000000
31	-	-		YE61253500000
32	FM	Fan*	220V-240VAC 40W	YM60121200400
33	M1	Blower**	220-240V/380-415V 0.2kW	BM30012500050
34	M2	Blower**	220-240V/380-415V 0.2kW	BM30012500050
35	M4	Motor*	200-240VAC 0.006 kW	YM50616400100

No.	Symbol	Name	SDD-20U/30H	
			Specifications	Part No.
36	EH1	Heater**	220-240V/380-415V 1.8kW	BH70160600150
37	EH2	Heater**	220-240V/380-415V 1.8kW	BH70300300050

* means possible broken parts.

** means easy broken part. and spare backup is suggested.

Please confirm the version of manual before placing the purchase order to guarantee that the item number of the spare part is in accordance with the real object.

Table 2-21 : Electrical Components List (PLC) (SDD-40U/30H)

No.	Symbol	Name	SDD-40U/30H	
			Specifications	Part No.
1	Q1	Main switch*	16A	YE10200300000
2	Q2	Circuit-breaker	15A	YE40000900000
3	Q3	Circuit-breaker*	5A	YE40601600000
4	K1	Contacto**	230VAC 50Hz	YE00301000000
5	K2	Contacto**	230VAC 50Hz	YE00301000000
6	K3	Contacto**	230VAC 50Hz	YE00301000000
7	K4	Contacto**	230VAC 50Hz	YE00301000000
8	K5	Phase protector	230VAC 50Hz	YE03103800000
9	K8	Relay	230VAC 50Hz 12A	YE03270700000
10	A1	PLC	100-230VAC 50/60Hz	YE81022400100
11	A2	Analog module	-	YE82023100100
12	A4	Human-machine interface	24VDC 0.4A	YE80211000000
13	A3	Analog module	-	YE82023100100
14	S13	Dew-point meter	POWER=24VDC OUT=4~20mA	YE15041200000
15	F1	Overload relay	1.25-2A	YE01063100000
16	F2	Overload relay	1.25-2A	YE01063100000
17	F4	Fuse*	2A Fuse	YE41001000000
18	S4	Limit switch*	250V~5(4)A	YE14152400000
19	S5 S6	Overheat protector*	250V~5(4)A	YE21503000000
20	S10 S11 S12	Thermocouple**	K	BE90802000050
21	U	DC power	OUT=DC24V 1.5A	YE71352400000
22	H1	Buzzer	60-250V AC/DC 5~35mA	YE84003500200
23	H2	Alarm indicate lamp	230VAC 50Hz	YE83305100300
24	T	Transformer**	IN=400V OUT=230V 500mA	YE70402300800
25	X1	Terminal board	32A 690V	YE61250000000
26	-	-	-	YE61253500000
27	X2	Terminal board	32A 690V	YE00300000000
28	X3	Terminal board	32A 690V	YE61250000000
29	-	-	-	YE61253500000
30	X4	Terminal board	32A 390V	YE61250000000
31	-	-	-	YE61253500000
32	FM	Fan*	220V-240VAC 40W	YM60121200400
33	M1	Blower**	220-240V/380-415V 0.2kW	BM30012500050
34	M2	Blower**	220-240V/380-415V 0.2kW	BM30012500050
35	M4	Motor*	200-240VAC 0.006 kW	YM50616400100
36	EH1	Heater**	220-240V/380-415V 2.8kW	BH70403900150

No.	Symbol	Name	SDD-40U/30H	
			Specifications	Part No.
37	EH2	Heater**	220-240V/380-415V 2.0kW	BH70300300050

* means possible broken parts.

** means easy broken part. and spare backup is suggested.

Please confirm the version of manual before placing the purchase order to guarantee that the item number of the spare part is in accordance with the real object.

Table 2-22 : Electrical Components List (PLC) (SDD-40U/50H)

No.	Symbol	Name	SDD-40U/50H	
			Specifications	Part No.
1	Q1	Main switch*	16A	YE10200300000
2	Q2	Circuit-breaker	15A	YE40000900000
3	Q3	Circuit-breaker*	5A	YE40601600000
4	K1	Contacto**	230VAC 50Hz	YE00301000000
5	K2	Contacto**	230VAC 50Hz	YE00301000000
6	K3	Contacto**	230VAC 50Hz	YE00301000000
7	K4	Contacto**	230VAC 50Hz	YE00301000000
8	K5	Phase protector	230VAC 50Hz	YE03103800000
9	K8	Relay	230VAC 50Hz 12A	YE03270700000
10	A1	PLC	100-230VAC 50/60Hz	YE81022400100
11	A2	Analog module	-	YE82023100100
12	A4	Human-machine interface	24VDC 0.4A	YE80211000000
13	A3	Analog module	-	YE82023100100
14	S13	Dew-point meter	POWER=24VDC OUT=4~20mA	YE15041200000
15	F1	Overload relay	1.25-2A	YE01063100000
16	F2	Overload relay	1.25-2A	YE01063100000
17	F4	Fuse*	2A Fuse	YE41001000000
18	S4	Limit switch*	250V~5(4)A	YE14152400000
19	S5 S6	Overheat protector*	250V~5(4)A	YE21503000000
20	S10 S11 S12	Thermocouple**	K	BE90802000050
21	U	DC power	OUT=DC24V 1.5A	YE71352400000
22	H1	Buzzer	60-250V AC/DC 5~35mA	YE84003500200
23	H2	Alarm indicate lamp	230VAC 50Hz	YE83305100300
24	T	Transformer**	IN=400V OUT=230V 500mA	YE70402300800
25	X1	Terminal board	32A 690V	YE61250000000
26	-	-	-	YE61253500000
27	X2	Terminal board	32A 690V	YE00300000000
28	X3	Terminal board	32A 690V	YE61250000000
29	-	-	-	YE61253500000
30	X4	Terminal board	32A 390V	YE61250000000
31	-	-	-	YE61253500000
32	FM	Fan*	220V-240VAC 40W	YM60121200400
33	M1	Blower**	220-240V/380-415V 0.2kW	BM30012500050
34	M2	Blower**	220-240V/380-415V 0.2kW	BM30012500050
35	M4	Motor*	200-240VAC 0.006 kW	YM50616400100
36	EH1	Heater**	220-240V/380-415V 2.8kW	BH70803900150

No.	Symbol	Name	SDD-40U/50H	
			Specifications	Part No.
37	EH2	Heater**	220-240V/380-415V 2.0kW	BH70300300050

* means possible broken parts.

** means easy broken part. and spare backup is suggested.

Please confirm the version of manual before placing the purchase order to guarantee that the item number of the spare part is in accordance with the real object.

Table 2-23 : Electrical Components List (PLC) (SDD-80U/50H)

No.	Symbol	Name	SDD-80U/50H	
			Specifications	Part No.
1	Q1	Main switch*	25A	YE10210300000
2	Q2	Circuit-breaker	15A	YE40000900000
3	Q3	Circuit-breaker*	5A	YE40601600000
4	K1	Contacto**	230VAC 50Hz	YE00301000000
5	K2	Contacto**	230VAC 50Hz	YE00301000000
6	K3	Contacto**	230VAC 50Hz	YE00301000000
7	K4	Contacto**	230VAC 50Hz	YE00301000000
8	K5	Phase protector	230VAC 50Hz	YE03103800000
9	K8	Relay	230VAC 50Hz 12A	YE03270700000
10	A1	PLC	100-230VAC 50/60Hz	YE81022400100
11	A2	Analog module	-	YE82023100100
12	A4	Human-machine interface	24VDC 0.4A	YE80211000000
13	A3	Analog module	-	YE82023100100
14	S13	Dew-point meter	POWER=24VDC OUT=4~20mA	YE15041200000
15	F1	Overload relay	1.25-2A	YE01011600000
16	F2	Overload relay	1.25-2A	YE01063100000
17	F4	Fuse*	2A Fuse	YE41001000000
18	S4	Limit switch*	250V~5(4)A	YE14152400000
19	S5 S6	Overheat protector*	250V~5(4)A	YE21503000000
20	S10 S11 S12	Thermocouple**	K	BE90802000050
21	U	DC power	OUT=DC24V 1.5A	YE71352400000
22	H1	Buzzer	60-250V AC/DC 5~35mA	YE84003500200
23	H2	Alarm indicate lamp	230VAC 50Hz	YE83305100300
24	T	Transformer**	IN=400V OUT=230V 500mA	YE70402300800
25	X1	Terminal board	32A 690V	YE61250000000
26	-	-	-	YE61253500000
27	X2	Terminal board	32A 690V	YE61250000000
28	X3	Terminal board	32A 690V	YE61250000000
29	-	-	-	YE61253500000
30	X4	Terminal board	32A 390V	YE61250000000
31	-	-	-	YE61253500000
32	FM	Fan*	220V-240VAC 40W	YM60121200400
33	M1	Blower**	220-240V/380-415V 0.4kW	BM30020500050
34	M2	Blower**	220-240V/380-415V 0.2kW	BM30012500050
35	M4	Motor*	200-240VAC 0.006 kW	YM50616400100
36	EH1	Heater**	220-240V/380-415V 3.9kW	BH70803900150

No.	Symbol	Name	SDD-80U/50H	
			Specifications	Part No.
37	EH2	Heater**	220-240V/380-415V 2.8kW	BH70500300050

* means possible broken parts.

** means easy broken part. and spare backup is suggested.

Please confirm the version of manual before placing the purchase order to guarantee that the item number of the spare part is in accordance with the real object.

Table 2-24 : Electrical Components List (PLC) (SDD-120U/80H)

No.	Symbol	Name	SDD-120U/80H	
			Specifications	Part No.
1	Q1	Main switch*	25A	YE10210300000
2	Q2	Circuit-breaker	20A	YE40000900000
3	Q3	Circuit-breaker*	10A	YE40602000100
4	K1	Contacto**	230VAC 50Hz	YE00321100000
5	K2	Contacto**	230VAC 50Hz	YE00301000000
6	K3	Contacto**	230VAC 50Hz	YE00301000000
7	K4	Contacto**	230VAC 50Hz	YE00301000000
8	K5	Phase protector	230VAC 50Hz	YE03103800000
9	K8	Relay	230VAC 50Hz 12A	YE03270700000
10	A1	PLC	100-230VAC 50/60Hz	YE81022400100
11	A2	Analog module	-	YE82023100100
12	A4	Human-machine interface	24VDC 0.4A	YE80211000000
13	A3	Analog module	-	YE82023100000
14	S13	Dew-point meter	POWER=24VDC OUT=4~20mA	YE15041200000
15	F1	Overload relay	2-3.2A	YE01023200000
16	F2	Overload relay	1.25-2A	YE01063100000
17	F4	Fuse*	2A Fuse	YE41001000000
18	S4	Limit switch*	250V~5(4)A	YE14152400000
19	S5 S6	Overheat protector*	250V~5(4)A	YE21503000000
20	S10 S11 S12	Thermocouple**	K	BE90802000050
21	U	DC power	OUT=DC24V 1.5A	YE71352400000
22	H1	Buzzer	60-250V AC/DC 5~35mA	YE84003500200
23	H2	Alarm indicate lamp	230VAC 50Hz	YE83305100300
24	T	Transformer**	IN=400V OUT=230V 500mA	YE70402300800
25	X1	Terminal board	32A 690V	YE61250000000
26	-	-	-	YE61253500000
27	X2	Terminal board	32A 690V	YE61250000000
28	X3	Terminal board	32A 690V	YE61250000000
29	-	-	-	YE61253500000
30	X4	Terminal board	32A 390V	YE61250000000
31	-	-		YE61253500000
32	FM	Fan*	220V-240VAC 40W	YM60121200400
33	M1	Blower**	220-240V/380-415V 0.75kW	BM30031000150
34	M2	Blower**	220-240V/380-415V 0.2kW	BM30012500050
35	M4	Motor*	200-240VAC 0.006 kW	YM50616400100
36	EH1	Heater**	220-240V/380-415V 3.9kW	BH70120600150

No.	Symbol	Name	SDD-120U/80H	
			Specifications	Part No.
37	EH2	Heater**	220-240V/380-415V 3.5kW	BH70800300050

* means possible broken parts.

** means easy broken part. and spare backup is suggested.

Please confirm the version of manual before placing the purchase order to guarantee that the item number of the spare part is in accordance with the real object.

Table 2-25 : Electrical Components List (PLC) (SDD-160U/80H)

No.	Symbol	Name	SDD-160U/80H	
			Specifications	Part No.
1	Q1	Main switch*	25A	YE10210300000
2	Q2	Circuit-breaker	20A	YE40000900000
3	Q3	Circuit-breaker*	10A	YE40602000100
4	K1	Contacto**	230VAC 50Hz	YE00321100000
5	K2	Contacto**	230VAC 50Hz	YE00301000000
6	K3	Contacto**	230VAC 50Hz	YE00301000000
7	K4	Contacto**	230VAC 50Hz	YE00301000000
8	K5	Phase protector	230VAC 50Hz	YE03103800000
9	K8	Relay	230VAC 50Hz 12A	YE03270700000
10	A1	PLC	100-230VAC 50/60Hz	YE81022400100
11	A2	Analog module	-	YE82023100100
12	A4	Human-machine interface	24VDC 0.4A	YE80211000000
13	A3	Analog module	-	YE82023100000
14	S13	Dew-point meter	POWER=24VDC OUT=4~20mA	YE15041200000
15	F1	Overload relay	2-3.2A	YE01023200000
16	F2	Overload relay	1.25-2A	YE01063100000
17	F4	Fuse*	2A Fuse	YE41001000000
18	S4	Limit switch*	250V~5(4)A	YE14152400000
19	S5 S6	Overheat protector*	250V~5(4)A	YE21503000000
20	S10 S11 S12	Thermocouple**	K	BE90802000050
21	U	DC power	OUT=DC24V 1.5A	YE71352400000
22	H1	Buzzer	60-250V AC/DC 5~35mA	YE84003500200
23	H2	Alarm indicate lamp	230VAC 50Hz	YE83305100300
24	T	Transformer**	IN=400V OUT=230V 500mA	YE70402300800
25	X1	Terminal board	32A 690V	YE61250000000
26	-	-	-	YE61253500000
27	X2	Terminal board	32A 690V	YE61250000000
28	X3	Terminal board	32A 690V	YE61250000000
29	-	-	-	YE61253500000
30	X4	Terminal board	32A 390V	YE61250000000
31	-	-	-	YE61253500000
32	FM	Fan*	220V-240VAC 40W	YM60121200400
33	M1	Blower**	220-240V/380-415V 0.75kW	BM30031000150
34	M2	Blower**	220-240V/380-415V 0.2kW	BM30012500050
35	M4	Motor*	200-240VAC 0.006 kW	YM50616400100
36	EH1	Heater**	220-240V/380-415V 5.7kW	BH70160600150

No.	Symbol	Name	SDD-160U/80H	
			Specifications	Part No.
37	EH2	Heater**	220-240V/380-415V 3.5kW	BH70800300050

* means possible broken parts.

** means easy broken part. and spare backup is suggested.

Please confirm the version of manual before placing the purchase order to guarantee that the item number of the spare part is in accordance with the real object.

Table 2-26 : Electrical Components List (PLC) (SDD-160U/120H)

No.	Symbol	Name	SDD-160U/120H	
			Specifications	Part No.
1	Q1	Main switch*	25A	YE10210300000
2	Q2	Circuit-breaker	20A	YE40000900000
3	Q3	Circuit-breaker*	10A	YE40632500000
4	K1	Contacto**	230VAC 50Hz	YE00301000000
5	K2	Contacto**	230VAC 50Hz	YE00301000000
6	K3	Contacto**	230VAC 50Hz	YE00321100000
7	K4	Contacto**	230VAC 50Hz	YE00301000000
8	K5	Phase protector	230VAC 50Hz	YE03103800000
9	K8	Relay	230VAC 50Hz 12A	YE03270700000
10	A1	PLC	100-230VAC 50/60Hz	YE81022400100
11	A2	Analog module	-	YE82023100100
12	A4	Human-machine interface	24VDC 0.4A	YE80211000000
13	A3	Analog module	-	YE82023100000
14	S13	Dew-point meter	POWER=24VDC OUT=4~20mA	YE15041200000
15	F1	Overload relay	2.5-4A	YE01025400000
16	F2	Overload relay	1.25-2A	YE01063100000
17	F4	Fuse*	2A Fuse	YE41001000000
18	S4	Limit switch*	250V~5(4)A	YE14152400000
19	S5 S6	Overheat protector*	250V~5(4)A	YE21503000000
20	S10 S11 S12	Thermocouple**	K	BE90802000050
21	U	DC power	OUT=DC24V 1.5A	YE71352400000
22	H1	Buzzer	60-250V AC/DC 5~35mA	YE84003500200
23	H2	Alarm indicate lamp	230VAC 50Hz	YE83305100300
24	T	Transformer**	IN=400V OUT=230V 500mA	YE70402300800
25	X1	Terminal board	32A 690V	YE61250000000
26	-	-	-	YE61253500000
27	X2	Terminal board	32A 690V	YE61250000000
28	X3	Terminal board	32A 690V	YE61250000000
29	-	-	-	YE61253500000
30	X4	Terminal board	32A 390V	YE61250000000
31	-	-	-	YE61253500000
32	FM	Fan*	220V-240VAC 40W	YM60121200400
33	M1	Blower**	220-240V/380-415V 1.5kW	BM30031000150
34	M2	Blower**	220-240V/380-415V 0.2kW	BM30012500050
35	M4	Motor*	200-240VAC 0.006 kW	YM50616400100
36	EH1	Heater**	220-240V/380-415V 6.0kW	BH70160600150

No.	Symbol	Name	SDD-160U/120H	
			Specifications	Part No.
37	EH2	Heater**	220-240V/380-415V 3.5kW	BH70800300050

* means possible broken parts.

** means easy broken part. and spare backup is suggested.

Please confirm the version of manual before placing the purchase order to guarantee that the item number of the spare part is in accordance with the real object.

Table 2-27 : Electrical Components List (PLC) (SDD-230U/120H)

No.	Symbol	Name	SDD-230U/120H	
			Specifications	Part No.
1	Q1	Main switch*	32A	YE10220300000
2	Q2	Circuit-breaker	20A	YE40000900000
3	Q3	Circuit-breaker*	10A	YE40632500000
4	K1	Contacto**	230VAC 50Hz	YE00301000000
5	K2	Contacto**	230VAC 50Hz	YE00301000000
6	K3	Contacto**	230VAC 50Hz	YE00321100000
7	K4	Contacto**	230VAC 50Hz	YE00301000000
8	K5	Phase protector	230VAC 50Hz	YE03103800000
9	K8	Relay	230VAC 50Hz 12A	YE03270700000
10	A1	PLC	100-230VAC 50/60Hz	YE81022400100
11	A2	Analog module	-	YE82023100100
12	A4	Human-machine interface	24VDC 0.4A	YE80211000000
13	A3	Analog module	-	YE82023100100
14	S13	Dew-point meter	POWER=24VDC OUT=4~20mA	YE15041200000
15	F1	Overload relay	2.5-4A	YE01025400000
16	F2	Overload relay	1.25-2A	YE01063100000
17	F4	Fuse*	2A Fuse	YE41001000000
18	S4	Limit switch*	250V~5(4)A	YE14152400000
19	S5 S6	Overheat protector*	250V~5(4)A	YE21503000000
20	S10 S11 S12	Thermocouple**	K	BE90802000050
21	U	DC power	OUT=DC24V 1.5A	YE71352400000
22	H1	Buzzer	60-250V AC/DC 5~35mA	YE84003500200
23	H2	Alarm indicate lamp	230VAC 50Hz	YE83305100300
24	T	Transformer**	IN=400V OUT=230V 500mA	YE70402300800
25	X1	Terminal board	32A 690V	YE61250000000
26	-	-	-	YE61253500000
27	X2	Terminal board	32A 690V	YE61250000000
28	X3	Terminal board	32A 690V	YE61250000000
29	-	-	-	YE61253500000
30	X4	Terminal board	32A 390V	YE61250000000
31	-	-	-	YE61253500000
32	FM	Fan*	220V-240VAC 40W	YM60121200400
33	M1	Blower**	220-240V/380-415V 1.5kW	BM30031000150
34	M2	Blower**	220-240V/380-415V 0.2kW	BM30012500050
35	M4	Motor*	200-240VAC 0.006 kW	YM50616400100
36	EH1	Heater**	220-240V/380-415V 6.0kW	BH70230600150

No.	Symbol	Name	SDD-230U/120H	
			Specifications	Part No.
37	EH2	Heater**	220-240V/380-415V 3.5kW	BH70800300050

* means possible broken parts.

** means easy broken part. and spare backup is suggested.

Please confirm the version of manual before placing the purchase order to guarantee that the item number of the spare part is in accordance with the real object.

Table 2-28 : Electrical Components List (PLC) (SDD-230U/150H)

No.	Symbol	Name	SDD-230U/150H	
			Specifications	Part No.
1	Q1	Main switch*	32A	YE10220300000
2	Q2	Circuit-breaker	20A	YE40000900000
3	Q3	Circuit-breaker*	10A	YE40633200000
4	K1	Contacto**	230VAC 50Hz	YE00301000000
5	K2	Contacto**	230VAC 50Hz	YE00301000000
6	K3	Contacto**	230VAC 50Hz	YE00321100000
7	K4	Contacto**	230VAC 50Hz	YE00301000000
8	K5	Phase protector	230VAC 50Hz	YE03103800000
9	K8	Relay	230VAC 50Hz 12A	YE03270700000
10	A1	PLC	100-230VAC 50/60Hz	YE81022400100
11	A2	Analog module	-	YE80211000000
12	A4	Human-machine interface	24VDC 0.4A	YE80601000000
13	A3	Analog module	-	YE82023100000
14	S13	Dew-point meter	POWER=24VDC OUT=4~20mA	YE15041200000
15	F1	Overload relay	2.5-4A	YE01025400000
16	F2	Overload relay	1.25-2A	YE01011600000
17	F4	Fuse*	2A Fuse	YE41001000000
18	S4	Limit switch*	250V~5(4)A	YE14152400000
19	S5 S6	Overheat protector*	250V~5(4)A	YE21503000000
20	S10 S11 S12	Thermocouple**	K	BE90802000050
21	U	DC power	OUT=DC24V 1.5A	YE71352400000
22	H1	Buzzer	60-250V AC/DC 5~35mA	YE84003500200
23	H2	Alarm indicate lamp	230VAC 50Hz	YE83305100300
24	T	Transformer**	IN=400V OUT=230V 500mA	YE70402300800
25	X1	Terminal board	32A 690V	YE61250000000
26	-	-	-	YE61253500000
27	X2	Terminal board	32A 690V	YE61250000000
28	X3	Terminal board	32A 690V	YE61250000000
29	-	-	-	YE61253500000
30	X4	Terminal board	32A 390V	YE61250000000
31	-	-		YE61253500000
32	FM	Fan*	220V-240VAC 40W	YM60121200400
33	M1	Blower**	220-240V/380-415V 1.9kW	BM30042000050
34	M2	Blower**	220-240V/380-415V 0.4kW	BM30020500050
35	M4	Motor*	200-240VAC 0.006 kW	YM50616400100
36	EH1	Heater**	220-240V/380-415V 6.0kW	BH70230600150

No.	Symbol	Name	SDD-230U/150H	
			Specifications	Part No.
37	EH2	Heater**	220-240V/380-415V 4.0kW	BH70150400050

* means possible broken parts.

** means easy broken part. and spare backup is suggested.

Please confirm the version of manual before placing the purchase order to guarantee that the item number of the spare part is in accordance with the real object.

Table 2-29 : Electrical Components List (PLC) (SDD-300U/150H)

No.	Symbol	Name	SDD-300U/150H	
			Specifications	Part No.
1	Q1	Main switch*	32A	YE10220300000
2	Q2	Circuit-breaker	20A	YE40000900000
3	Q3	Circuit-breaker*	10A	YE40634000000
4	K1	Contacto**	230VAC 50Hz	YE00301000000
5	K2	Contacto**	230VAC 50Hz	YE00301000000
6	K3	Contacto**	230VAC 50Hz	YE00341100000
7	K4	Contacto**	230VAC 50Hz	YE00301000000
8	K5	Phase protector	230VAC 50Hz	YE03103800000
9	K8	Relay	230VAC 50Hz 12A	YE03270700000
10	A1	PLC	100-230VAC 50/60Hz	YE81022400100
11	A2	Analog module	-	YE80211000000
12	A4	Human-machine interface	24VDC 0.4A	YE80601000000
13	A3	Analog module	-	YE82023100000
14	S13	Dew-point meter	POWER=24VDC OUT=4~20mA	YE15041200000
15	F1	Overload relay	2.5-4A	YE01025400000
16	F2	Overload relay	1.25-2A	YE01011600000
17	F4	Fuse*	2A Fuse	YE41001000000
18	S4	Limit switch*	250V~5(4)A	YE14152400000
19	S5 S6	Overheat protector*	250V~5(4)A	YE21503000000
20	S10 S11 S12	Thermocouple**	K	BE90802000050
21	U	DC power	OUT=DC24V 1.5A	YE71352400000
22	H1	Buzzer	60-250V AC/DC 5~35mA	YE84003500200
23	H2	Alarm indicate lamp	230VAC 50Hz	YE83305100300
24	T	Transformer**	IN=400V OUT=230V 500mA	YE70402300800
25	X1	Terminal board	32A 690V	YE61250000000
26	-	-	-	YE61253500000
27	X2	Terminal board	32A 690V	YE61250000000
28	X3	Terminal board	32A 690V	YE61250000000
29	-	-	-	YE61253500000
30	X4	Terminal board	32A 390V	YE61250000000
31	-	-		YE61253500000
32	FM	Fan*	220V-240VAC 40W	YM60121200400
33	M1	Blower**	220-240V/380-415V 1.9kW	BM30042000050
34	M2	Blower**	220-240V/380-415V 0.4kW	BM30020500050
35	M4	Motor*	200-240VAC 0.006 kW	YM50616400100
36	EH1	Heater**	220-240V/380-415V 12kW	BH70307200150

No.	Symbol	Name	SDD-300U/150H	
			Specifications	Part No.
37	EH2	Heater**	220-240V/380-415V 3.5kW	BH70150400050

* means possible broken parts.

** means easy broken part. and spare backup is suggested.

Please confirm the version of manual before placing the purchase order to guarantee that the item number of the spare part is in accordance with the real object.

Table 2-30 : Electrical Components List (PLC) (SDD-300U/200H)

No.	Symbol	Name	SDD-300U/200H	
			Specifications	Part No.
1	Q1	Main switch*	63A	YE10250400000
2	Q2	Circuit-breaker	32A	YE40000900000
3	Q3	Circuit-breaker*	10A	YE40634000000
4	K1	Contacto**	230VAC 50Hz	YE00301000000
5	K2	Contacto**	230VAC 50Hz	YE00301000000
6	K3	Contacto**	230VAC 50Hz	YE00301000000
7	K4	Contacto**	230VAC 50Hz	YE00341100000
8	K5	Phase protector	230VAC 50Hz	YE03103800000
9	K8	Relay	230VAC 50Hz 12A	YE03270700000
10	A1	PLC	100-230VAC 50/60Hz	YE81022400100
11	A2	Analog module	-	YE82023100100
12	A4	Human-machine interface	24VDC 0.4A	YE80601000000
13	A3	Analog module	-	YE82023100000
14	S13	Dew-point meter	POWER=24VDC OUT=4~20mA	YE15041200000
15	F1	Overload relay	2.5-4A	YE01025400000
16	F2	Overload relay	1.25-2A	YE01011600000
17	F4	Fuse*	2A Fuse	YE41001000000
18	S4	Limit switch*	250V~5(4)A	YE14152400000
19	S5 S6	Overheat protector*	250V~5(4)A	YE21503000000
20	S10 S11 S12	Thermocouple**	K	BE90802000050
21	U	DC power	OUT=DC24V 1.5A	YE71352400000
22	H1	Buzzer	60-250V AC/DC 5~35mA	YE84003500200
23	H2	Alarm indicate lamp	230VAC 50Hz	YE83305100300
24	T	Transformer**	IN=400V OUT=230V 500mA	YE70402300800
25	X1	Terminal board	57A 690V	YE61060000000
26	-	-	-	YE61063500000
27	-	-	41A 690V	YE61040000000
28	-	-	-	YE61043500000
29	-	-	32A 690V	YE61250000000
30	-	-	-	YE61253500000
31	X2	Terminal board	32A 390V	YE61250000000
32	X3	Terminal board	32A 390V	YE61250000000
33	-	-		YE61253500000
34	X4	Terminal board	32A 390V	YE61250000000
35	-	-		YE61253500000
36	FM	Fan*	220V-240VAC 40W	YM60121200400

No.	Symbol	Name	SDD-300U/200H	
			Specifications	Part No.
37	M1	Blower**	220-240V/380-415V 1.9kW	BM30042000050
38	M2	Blower**	220-240V/380-415V 0.4kW	BM30020500050
39	M4	Motor*	200-240VAC 0.006 kW	YM50616400100
40	EH1	Heater**	220-240V/380-415V 15kW	BH70200400050
41	EH2	Heater**	220-240V/380-415V 5.4kW	BH70451200150

* means possible broken parts.

** means easy broken part. and spare backup is suggested.

Please confirm the version of manual before placing the purchase order to guarantee that the item number of the spare part is in accordance with the real object.

Table 2-31 : Electrical Components List (PLC) (SDD-450U/300H)

No.	Symbol	Name	SDD-450U/300H	
			Specifications	Part No.
1	Q1	Main switch*	63A	YE10250400000
2	Q2	Circuit-breaker	40A	YE40303000000
3	Q3	Circuit-breaker*	-	YE40305000000
4	K1	Contacto**	230VAC 50Hz	-
5	K2	Contacto**	230VAC 50Hz	YE00311000000
6	K3	Contacto**	230VAC 50Hz	YE00301000000
7	K4	Contacto**	230VAC 50Hz	YE00301000000
8	K5	Phase protector	230VAC 50Hz	YE03103800000
9	K8	Relay	230VAC 50Hz 12A	YE03270700000
10	A1	PLC	100-230VAC 50/60Hz	YE81022400100
11	A2	Analog module	-	YE82023100100
12	A4	Human-machine interface	24VDC 0.4A	YE80211000000
13	A3	Analog module	-	YE82023100000
14	S13	Dew-point meter	POWER=24VDC OUT=4~20mA	YE15041200000
15	F1	Overload relay	4-6.3A	YE01046300100
16	F2	Overload relay	2-3.2A	YE01023200000
17	F4	Fuse*	2A Fuse	YE41001000000
18	S4	Limit switch*	250V~5(4)A	YE14152400000
19	S5 S6	Overheat protector*	250V~5(4)A	YE21503000000
20	S10 S11 S12	Thermocouple**	K	BE90802000050
21	U	DC power	OUT=DC24V 1.5A	YE71352400000
22	H1	Buzzer	60-250V AC/DC 5~35mA	YE84003500200
23	H2	Alarm indicate lamp	230VAC 50Hz	YE83305100300
24	T	Transformer**	IN=400V OUT=230V 500mA	YE70402300800
25	X1	Terminal board	76A 690V	YE61100000000
26	-	-	-	YE61103500000
27	-	-	41A 690V	YE61040000000
28	-	-	-	YE61043500000
29	-	-	32A 690V	YE61250000000
30	X2	Terminal board	32A 390V	YE61250000000
31	X3	Terminal board	32A 390V	YE61250000000
32	-	-		YE61253500000
33	X4	Terminal board	32A 390V	YE61250000000
34	-	-		YE61253500000
35	FM	Fan*	220V-240VAC 40W	YM60121200400
36	M1	Blower**	220-240V/380-415V 2.6kW	BM30053500050

No.	Symbol	Name	SDD-450U/300H	
			Specifications	Part No.
37	M2	Blower**	220-240V/380-415V 0.75kW	BM30031000150
38	M4	Motor*	200-240VAC 0.006 kW	YM50616400100
39	EH1	Heater**	220-240V/380-415V 15kW	BH70307200250
40	EH2	Heater**	220-240V/380-415V 7.2kW	BH70601500150

* means possible broken parts.

** means easy broken part. and spare backup is suggested.

Please confirm the version of manual before placing the purchase order to guarantee that the item number of the spare part is in accordance with the real object.

Table 2-32 : Electrical Components List (PLC) (SDD-600U/300H)

No.	Symbol	Name	SDD-600U/300H	
			Specifications	Part No.
1	Q1	Main switch*	63A	YE10250400000
2	Q2	Circuit-breaker	50A	YE40000900000
3	Q3	Circuit-breaker*	-	YE40636300000
4	K1	Contacto**	230VAC 50Hz	YE00351100100
5	K2	Contacto**	230VAC 50Hz	YE00321100000
6	K3	Contacto**	230VAC 50Hz	YE00301000000
7	K4	Contacto**	230VAC 50Hz	YE00301000000
8	K5	Phase protector	230VAC 50Hz	YE03103800000
9	K8	Relay	230VAC 50Hz 12A	YE03270700000
10	A1	PLC	100-230VAC 50/60Hz	YE81022400100
11	A2	Analog module	-	YE82023100100
12	A4	Human-machine interface	24VDC 0.4A	YE80211000000
13	A3	Analog module	-	YE82023100000
14	S13	Dew-point meter	POWER=24VDC OUT=4~20mA	YE15041200000
15	F1	Overload relay	4-6.3A	YE01046300100
16	F2	Overload relay	2-3.2A	YE01023200000
17	F4	Fuse*	2A Fuse	YE41001000000
18	S4	Limit switch*	250V~5(4)A	YE14152400000
19	S5 S6	Overheat protector*	250V~5(4)A	YE21503000000
20	S10 S11 S12	Thermocouple**	K	BE90802000050
21	U	DC power	OUT=DC24V 1.5A	YE71352400000
22	H1	Buzzer	60-250V AC/DC 5~35mA	YE84003500200
23	H2	Alarm indicate lamp	230VAC 50Hz	YE83305100300
24	T	Transformer**	IN=400V OUT=230V 500mA	YE70402300800
25	X1	Terminal board	76A 690V	YE61100000000
26	-	-	-	YE61103500000
27	-	-	41A 690V	YE61040000000
28	-	-	-	YE61043500000
29	-	-	32A 690V	YE61250000000
30	X2	Terminal board	32A 390V	YE61250000000
31	X3	Terminal board	32A 390V	YE61250000000
32	-	-		YE61253500000
33	X4	Terminal board	32A 390V	YE61250000000
34	-	-		YE61253500000
35	FM	Fan*	220V-240VAC 40W	YM60121200400
36	M1	Blower**	220-240V/380-415V 2.6kW	BM30053500050

No.	Symbol	Name	SDD-600U/300H	
			Specifications	Part No.
37	M2	Blower**	220-240V/380-415V 0.75kW	BM30031000150
38	M4	Motor*	200-240VAC 0.006 kW	YM50616400100
39	EH1	Heater**	220-240V/380-415V 18kW	BH70307200250
40	EH2	Heater**	220-240V/380-415V 7.2kW	BH70601500150

* means possible broken parts.

** means easy broken part. and spare backup is suggested.

Please confirm the version of manual before placing the purchase order to guarantee that the item number of the spare part is in accordance with the real object.

Table 2-33 : Electrical Components List (PLC) (SDD-600U/400H)

No.	Symbol	Name	SDD-600U/400H	
			Specifications	Part No.
1	Q1	Main switch*	63A	YE10250400000
2	Q2	Circuit-breaker	50A	YE40000900000
3	Q3	Circuit-breaker*	-	YE40636300000
4	K1	Contacto**	230VAC 50Hz	YE00321100000
5	K2	Contacto**	230VAC 50Hz	YE00331100000
6	K3	Contacto**	230VAC 50Hz	YE00301000000
7	K4	Contacto**	230VAC 50Hz	YE00301000000
8	K5	Phase protector	230VAC 50Hz	YE03103800000
9	K8	Relay	230VAC 50Hz 12A	YE03270700000
10	A1	PLC	100-230VAC 50/60Hz	YE81022400100
11	A2	Analog module	-	YE82023100100
12	A4	Human-machine interface	24VDC 0.4A	YE80211000000
13	A3	Analog module	-	YE82023100000
14	S13	Dew-point meter	POWER=24VDC OUT=4~20mA	YE15041200000
15	F1	Overload relay	5-8A	YE01050800000
16	F2	Overload relay	2-3.2A	YE01023200000
17	F4	Fuse*	2A Fuse	YE41001000000
18	S4	Limit switch*	250V~5(4)A	YE14152400000
19	S5 S6	Overheat protector*	250V~5(4)A	YE21503000000
20	S10 S11 S12	Thermocouple**	K	BE90802000050
21	U	DC power	OUT=DC24V 1.5A	YE71352400000
22	H1	Buzzer	60-250V AC/DC 5~35mA	YE84003500200
23	H2	Alarm indicate lamp	230VAC 50Hz	YE83305100300
24	T	Transformer**	IN=400V OUT=230V 500mA	YE70402300800
25	X1	Terminal board	76A 690V	YE61100000000
26	-	-	-	YE61103500000
27	-	-	57A 690V	YE61060000000
28	-	-	-	YE61063500000
29	-	-	32A 690V	YE61250000000
30	-	Terminal board	-	YE61250000000
31	X3	Terminal board	32A 390V	YE61250000000
32	-	-	-	YE61253500000
33	X4	Terminal board	32A 390V	YE61250000000
34	-	-	-	YE61253500000
35	FM	Fan*	220V-240VAC 40W	YM60121200400
36	M1	Blower**	220-240V/380-415V 3.7kW	BM30055000050

No.	Symbol	Name	SDD-600U/400H	
			Specifications	Part No.
37	M2	Blower**	220-240V/380-415V 0.75kW	BM30031000150
38	M4	Motor*	200-240VAC 0.015 kW	YM50616400100
39	EH1	Heater**	220-240V/380-415V 18kW	BH70100000050
40	EH2	Heater**	220-240V/380-415V 7.2kW	BH70601500150

* means possible broken parts.

** means easy broken part. and spare backup is suggested.

Please confirm the version of manual before placing the purchase order to guarantee that the item number of the spare part is in accordance with the real object.

Table 2-34 : Electrical Components List (PLC) (SDD-750U/400H)

No.	Symbol	Name	SDD-750U/400H	
			Specifications	Part No.
1	Q1	Main switch*	63A	YE10250400000
2	Q2	Circuit-breaker	50A	YE40000900000
3	Q3	Circuit-breaker*	-	YE40636300000
4	K1	Contacto**	230VAC 50Hz	YE00321100000
5	K2	Contacto**	230VAC 50Hz	YE00331100000
6	K3	Contacto**	230VAC 50Hz	YE00301000000
7	K4	Contacto**	230VAC 50Hz	YE00301000000
8	K5	Phase protector	230VAC 50Hz	YE03103800000
9	K8	Relay	230VAC 50Hz 12A	YE03270700000
10	A1	PLC	100-230VAC 50/60Hz	YE81022400100
11	A2	Analog module	-	YE82023100100
12	A4	Human-machine interface	24VDC 0.4A	YE80211000000
13	A3	Analog module	-	YE82023100000
14	S13	Dew-point meter	POWER=24VDC OUT=4~20mA	YE15041200000
15	F1	Overload relay	5-8A	YE01050800000
16	F2	Overload relay	2-3.2A	YE01023200000
17	F4	Fuse*	2A Fuse	YE41001000000
18	S4	Limit switch*	250V~5(4)A	YE14152400000
19	S5 S6	Overheat protector*	250V~5(4)A	YE21503000000
20	S10 S11 S12	Thermocouple**	K	BE90802000050
21	U	DC power	OUT=DC24V 1.5A	YE71352400000
22	H1	Buzzer	60-250V AC/DC 5~35mA	YE84003500200
23	H2	Alarm indicate lamp	230VAC 50Hz	YE83305100300
24	T	Transformer**	IN=400V OUT=230V 500mA	YE70402300800
25	X1	Terminal board	76A 690V	YE61100000000
26	-	-	-	YE61103500000
27	-	-	57A 690V	YE61060000000
28	-	-	-	YE61063500000
29	-	-	32A 690V	YE61250000000
30	-	-	-	YE61250000000
31	X3	Terminal board	32A 390V	YE61250000000
32	-	-	-	YE61253500000
33	X4	Terminal board	32A 390V	YE61250000000
34	-	-	-	YE61253500000
35	FM	Fan*	220V-240VAC 40W	YM60121200400
36	M1	Blower**	220-240V/380-415V 3.7kW	BM30055000050

No.	Symbol	Name	SDD-750U/400H	
			Specifications	Part No.
37	M2	Blower**	220-240V/380-415V 0.75kW	BM30031000150
38	M4	Motor*	200-240VAC 0.015 kW	YM50616400100
39	EH1	Heater**	220-240V/380-415V 18kW	BH70100000050
40	EH2	Heater**	220-240V/380-415V 7.2kW	BH70751800150

* means possible broken parts.

** means easy broken part. and spare backup is suggested.

Please confirm the version of manual before placing the purchase order to guarantee that the item number of the spare part is in accordance with the real object.

Table 2-35 : Electrical Components List (PLC) (SDD-750U/500H)

No.	Symbol	Name	SDD-750U/500H	
			Specifications	Part No.
1	Q1	Main switch*	80A	YE40601500000
2	Q2	Circuit-breaker	60A	YE40000900000
3	Q3	Circuit-breaker*	-	YE40636300000
4	K1	Contacto**	230VAC 50Hz	YE00321100000
5	K2	Contacto**	230VAC 50Hz	YE00331100000
6	K3	Contacto**	230VAC 50Hz	YE00331100000
7	K4	Contacto**	230VAC 50Hz	YE00301000000
8	K5	Phase protector	230VAC 50Hz	YE03103800000
9	K8	Relay	230VAC 50Hz 12A	YE03270700000
10	A1	PLC	100-230VAC 50/60Hz	YE81022400100
11	A2	Analog module	-	YE82023100100
12	A4	Human-machine interface	24VDC 0.4A	YE80211000000
13	A3	Analog module	-	YE82023100000
14	S13	Dew-point meter	POWER=24VDC OUT=4~20mA	YE15041200000
15	F1	Overload relay	10-16A	YE01101600100
16	F2	Overload relay	2.5-4A	YE01025400000
17	F4	Fuse*	2A Fuse	YE41001000000
18	S4	Limit switch*	250V~5(4)A	YE14152400000
19	S5 S6	Overheat protector*	250V~5(4)A	YE21503000000
20	S10 S11 S12	Thermocouple**	K	BE90802000050
21	U	DC power	OUT=DC24V 1.5A	YE71352400000
22	H1	Buzzer	60-250V AC/DC 5~35mA	YE84003500200
23	H2	Alarm indicate lamp	230VAC 50Hz	YE83305100300
24	T	Transformer**	IN=400V OUT=230V 500mA	YE70402300800
25	X1	Terminal board	76A 690V	YE61100000000
26	-	-	-	YE61103500000
27	-	-	32A 690V	YE61250000000
28	-	-	-	YE61253500000
29	X3	Terminal board	32A 390V	YE61250000000
30	-	-	-	YE61253500000
31	X4	Terminal board	32A 390V	YE61250000000
32	-	-	-	YE61253500000
33	FM	Fan*	220V-240VAC 40W	YM60121200400
34	M1	Blower**	220-240V/380-415V 5.5kW	YM30072900000
35	M2	Blower**	220-240V/380-415V 1.5kW	BM30042000050
36	M4	Motor*	200-240VAC 0.015 kW	YM50616400100

No.	Symbol	Name	SDD-750U/500H	
			Specifications	Part No.
37	EH1	Heater**	220-240V/380-415V 10.5kW	BH70902100150
38	EH2	Heater**	220-240V/380-415V 10kW	BH70501000050

* means possible broken parts.

** means easy broken part. and spare backup is suggested.

Please confirm the version of manual before placing the purchase order to guarantee that the item number of the spare part is in accordance with the real object.

Table 2-36 : Electrical Components List (PLC) (SDD-900U/500H)

No.	Symbol	Name	SDD-900U/500H	
			Specifications	Part No.
1	Q1	Main switch*	80A	YE40601500000
2	Q2	Circuit-breaker	60A	YE40000900000
3	Q3	Circuit-breaker*	-	YE40636300000
4	K1	Contacto**	230VAC 50Hz	YE00321100000
5	K2	Contacto**	230VAC 50Hz	YE00331100000
6	K3	Contacto**	230VAC 50Hz	YE00331100000
7	K4	Contacto**	230VAC 50Hz	YE00301000000
8	K5	Phase protector	230VAC 50Hz	YE03103800000
9	K8	Relay	230VAC 50Hz 12A	YE03270700000
10	A1	PLC	100-230VAC 50/60Hz	YE81022400100
11	A2	Analog module	-	YE82023100100
12	A4	Human-machine interface	24VDC 0.4A	YE80211000000
13	A3	Analog module	-	YE82023100000
14	S13	Dew-point meter	POWER=24VDC OUT=4~20mA	YE15041200000
15	F1	Overload relay	10-16A	YE01101600100
16	F2	Overload relay	2.5-4A	YE01025400000
17	F4	Fuse*	2A Fuse	YE41001000000
18	S4	Limit switch*	250V~5(4)A	YE14152400000
19	S5 S6	Overheat protector*	250V~5(4)A	YE21503000000
20	S10 S11 S12	Thermocouple**	K	BE90802000050
21	U	DC power	OUT=DC24V 1.5A	YE71352400000
22	H1	Buzzer	60-250V AC/DC 5~35mA	YE84003500200
23	H2	Alarm indicate lamp	230VAC 50Hz	YE83305100300
24	T	Transformer**	IN=400V OUT=230V 500mA	YE70402300800
25	X1	Terminal board	76A 690V	YE61100000000
26	-	-	-	YE61103500000
27	-	-	32A 690V	YE61250000000
28	-	-	-	YE61253500000
29	X3	Terminal board	32A 390V	YE61250000000
30	-	-	-	YE61253500000
31	X4	Terminal board	32A 390V	YE61250000000
32	-	-	-	YE61253500000
33	FM	Fan*	220V-240VAC 40W	YM60121200400
34	M1	Blower**	220-240V/380-415V 5.5kW	YM30072900000
35	M2	Blower**	220-240V/380-415V 1.5kW	BM30042000050
36	M4	Motor*	200-240VAC 0.015 kW	YM50616400100

No.	Symbol	Name	SDD-900U/500H	
			Specifications	Part No.
37	EH1	Heater**	220-240V/380-415V 10.5kW	BH70902100150
38	EH2	Heater**	220-240V/380-415V 10kW	BH70501000050

* means possible broken parts.

** means easy broken part. and spare backup is suggested.

Please confirm the version of manual before placing the purchase order to guarantee that the item number of the spare part is in accordance with the real object.

Table 2-37 : Electrical Components List (PLC) (SDD-900U/700H)

No.	Symbol	Name	SDD-900U/700H	
			Specifications	Part No.
1	Q1	Main switch*	80A	YE40601500000
2	Q2	Circuit-breaker	60A	YE40636300000
3	Q3	Circuit-breaker*	-	YE40602500000
4	K1	Contacto**	230VAC 50Hz	YE00320000000
5	K2	Contacto**	230VAC 50Hz	YE00330000000
6	K3	Contacto**	230VAC 50Hz	YE00330000000
7	K4	Contacto**	230VAC 50Hz	YE00330000000
8	K5	Phase protector	230VAC 50Hz	YE03103800000
9	K8	Relay	230VAC 50Hz 12A	YE03270700000
10	A1	PLC	100-230VAC 50/60Hz	YE81022400100
11	A2	Analog module	-	YE82023100100
12	A4	Human-machine interface	24VDC 0.4A	YE80211000000
13	A3	Analog module	-	YE82023100000
14	S13	Dew-point meter	POWER=24VDC OUT=4~20mA	YE15041200000
15	F1	Overload relay	10-16A	YE01101600100
16	F2	Overload relay	2.5-4A	YE01025400000
17	F4	Fuse*	2A Fuse	YE41001000000
18	S4	Limit switch*	250V~5(4)A	YE14152400000
19	S5 S6	Overheat protector*	250V~5(4)A	YE21503000000
20	S10 S11 S12	Thermocouple**	K	BE90802000050
21	U	DC power	OUT=DC24V 1.5A	YE71352400000
22	H1	Buzzer	60-250V AC/DC 5~35mA	YE84003500200
23	H2	Alarm indicate lamp	230VAC 50Hz	YE83305100300
24	T	Transformer**	IN=400V OUT=230V 500mA	YE70402300800
25	X1	Terminal board	76A 690V	YE61100000000
26	-	-	-	YE61103500000
27	-	-	41A 690V	YE61040000000
28	-	-	-	YE61043500000
29	-	Terminal board	32A 690V	YE61250000000
30	-	-	-	YE61253500000
31	X3	Terminal board	32A 390V	YE61250000000
32	-	-	-	YE61253500000
33	X4	Fan*	32A 390V	YE61250000000
34	-	Blower**		YE61253500000
35	FM	Blower**	220V-240VAC 40W	YM60121200400
36	M1	Motor*	220-240V/380-415V 5.5kW	YM30072900000

No.	Symbol	Name	SDD-900U/700H	
			Specifications	Part No.
37	M2	Heater**	220-240V/380-415V 1.5kW	BM30042000050
38	M4	Heater**	200-240VAC 0.015 kW	YM50616400100
39	EH1	Main switch*	220-240V/380-415V 12kW	BH70122400150
40	EH2	Circuit-breaker	220-240V/380-415V 10kW	BH70501000050

* means possible broken parts.

** means easy broken part. and spare backup is suggested.

Please confirm the version of manual before placing the purchase order to guarantee that the item number of the spare part is in accordance with the real object.

Table 2-38 : Electrical Components List (PLC) (SDD-1200U/700H)

No.	Symbol	Name	SDD-1200U/700H	
			Specifications	Part No.
1	Q1	Main switch*	100A	YE40601500000
2	Q2	Circuit-breaker	50A	YE40636300000
3	Q3	Circuit-breaker*	-	YE40602500000
4	K1	Contacto**	230VAC 50Hz	YE00321100000
5	K2	Contacto**	230VAC 50Hz	YE00301000000
6	K3	Contacto**	230VAC 50Hz	YE00341100000
7	K4	Contacto**	230VAC 50Hz	YE00331100000
8	K5	Phase protector	230VAC 50Hz	YE03103800000
9	K8	Relay	230VAC 50Hz 12A	YE03270700000
10	A1	PLC	100-230VAC 50/60Hz	YE81022400100
11	A2	Analog module	-	YE82023100100
12	A4	Human-machine interface	24VDC 0.4A	YE80211000000
13	A3	Analog module	-	YE82023100000
14	S13	Dew-point meter	POWER=24VDC OUT=4~20mA	YE15041200000
15	F1	Overload relay	10-16A	YE01101600100
16	F2	Overload relay	2.5-4A	YE01025400000
17	F4	Fuse*	2A Fuse	YE41001000000
18	S4	Limit switch*	250V~5(4)A	YE14152400000
19	S5 S6	Overheat protector*	250V~5(4)A	YE21503000000
20	S10 S11 S12	Thermocouple**	K	BE90802000050
21	U	DC power	OUT=DC24V 1.5A	YE71352400000
22	H1	Buzzer	60-250V AC/DC 5~35mA	YE84003500200
23	H2	Alarm indicate lamp	230VAC 50Hz	YE83305100300
24	T	Transformer**	IN=400V OUT=230V 500mA	YE70402300800
25	X1	Terminal board	76A 690V	YE61100000000
26	-	-	-	YE61103500000
27	-	-	41A 690V	YE61040000000
28	-	-	-	YE61043500000
29	-	-	32A 690V	YE61250000000
30	-	-	-	YE61253500000
31	X3	Terminal board	32A 390V	YE61250000000
32	-	-	-	YE61253500000
33	X4	Terminal board	32A 390V	YE61250000000
34	-	-	-	YE61253500000
35	FM	Fan*	220V-240VAC 40W	YM60121200400
36	M1	Blower**	220-240V/380-415V 5.5kW	YM30072900000

No.	Symbol	Name	SDD-1200U/700H	
			Specifications	Part No.
37	M2	Blower**	220-240V/380-415V 1.5kW	BM30042000050
38	M4	Motor*	200-240VAC 0.015 kW	YM50616400100
39	EH1	Heater**	220-240V/380-415V 12kW	BH70122400150
40	EH2	Heater**	220-240V/380-415V 10kW	BH70501000050

* means possible broken parts.

** means easy broken part. and spare backup is suggested.

Please confirm the version of manual before placing the purchase order to guarantee that the item number of the spare part is in accordance with the real object.

2.8.12 Main Electrical Components Description

Overload Relay

At delivery, the overload relay is set for manual reset. (the reset button pointing to H). Manually reset the relay at the tripping of the switch. When motor overload occurs, stop the machine, then check and solve the problem. After that open the door of control box, press down the reset button of overload relay (if you can not press down the reset button, wait for one minute.)

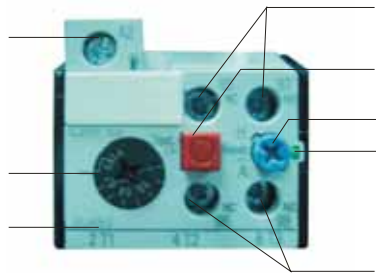

Picture 2-17 : Overload Relay

- 1) Terminal for contact coil A2.
- 2) Setting current adjusting scale.
- 3) Reset (blue)
- H: manual reset
- A: automatic reset
- 4) Switch position indication (green).

Tripping of a manual-resetting is indicated by a pin projecting from the front plate.

- 5) Test button (red).
- 6) Auxiliary contact terminals shown in 95.96.97.98. NC and NO contacts are shown in position 95.96. and 97.98. respectively.
- 7) Main circuit connection No. must be correspond with terminal Number of contactor.

2.9 Operation Procedures



Before connecting electrical power source, the main power switch must be turned to OFF position. After the machine connected with power source, turn the main power switch to ON position. According to your applications, operate drying and loading system respectively.

2.9.1 Operation Regulations



Picture 2-18 : Operation Regulations

- 1) Do not use keen-edged object instead of hands to operate the touch screen, and prevent violent collision of it.
- 2) In a dry environment, static electricity may accumulated on the touch screen. Use a metal wire to discharge it before operating.
- 3) Use alcohol or eleoptene to wipe off the pollutants on the screen. Other solvent may cause the color of the screen to fade out.
- 4) Do not tear down any parts of the touch screen or take away any PCBs attached to it.

2.9.2 Description of Touch Screen

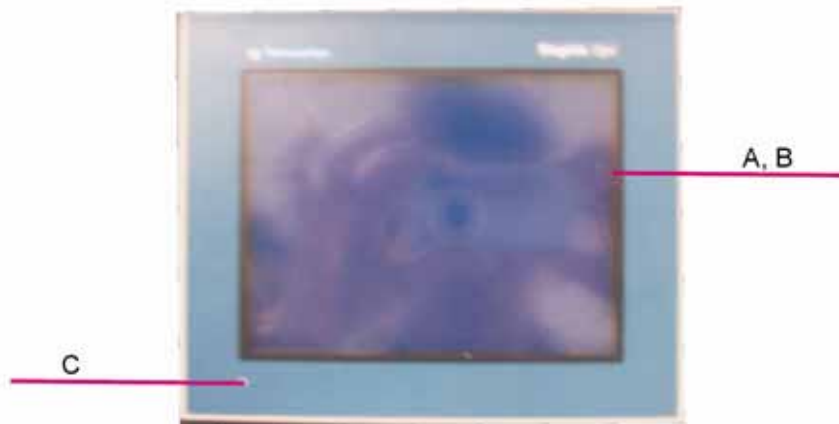

Picture 2-19 : Description of Touch Screen

A : Display

B : Touch panel

C : LED status indicator

2.9.3 Touch Panel Appear Error

Table 2-39 : Touch panel information

LED indicator light	XBT GT State
Green (light)	Work welled
Orange (light)	Backlight lamp burning
Orange (shine)	During software startup
Red (light)	Power status
No shine	Power break off

3. Operation of the Menus

The system consists of six main menus. They are: drying process, temperature parameters, rotor parameters, time setting, alarm records and help menu.

Please refer to following flow Table.

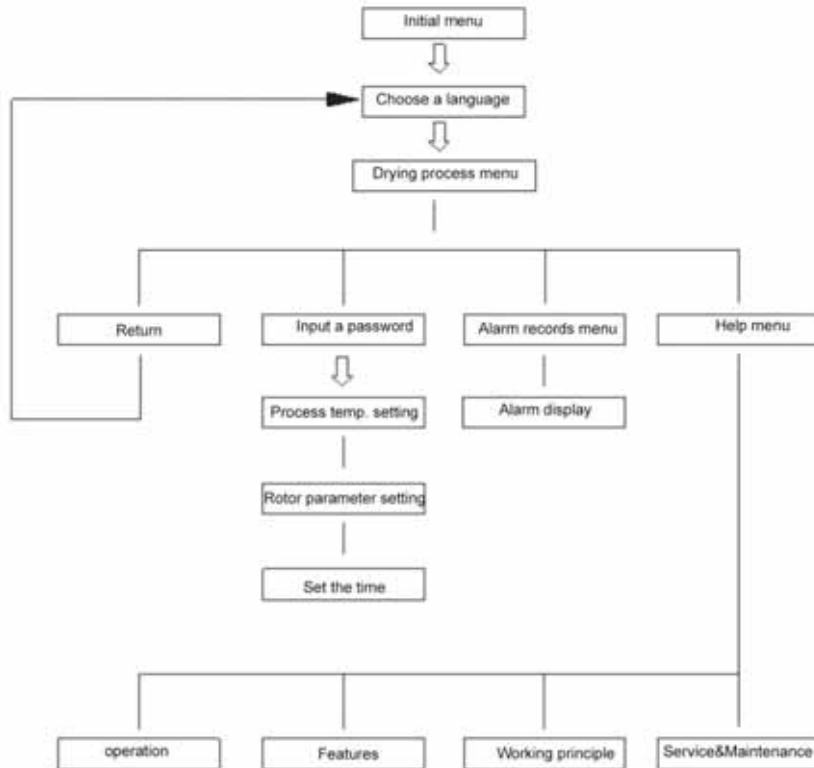

Picture 2-20 : Screen Operation Flow Table

4. Explanation of the Menus

1) Initial menu

Please refer to the following initial menu. Press “English” or “Chinese” to select a language. Then enter drying process menu.



Picture 2-21 : System Default System

2) Drying process menu.

Drying process menu as shown below:

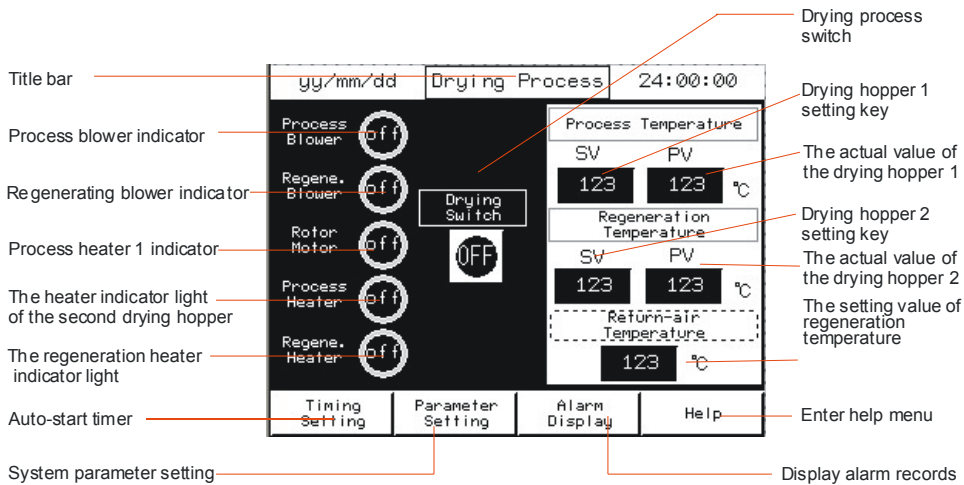

Picture 2-22 : Drying Process Screen

A. Operation of the menu

Start drying process:

Touch switch to make it show ON, then the system starts.

Stop process:

Touch the switch again to make it show OFF, then the system stops running.

(Attention: In order to prolong the life of honeycomb-rotor, extended cooling time is needed to cool the rotor. Set the delayed time at about 3 minutes.

Set process temp.

Touch the preset value of process temp. A numerical keypad will appear. Use the keypad to enter temp.

Touch the preset value of regenerating temp. A keypad will appear.

Use the keypad to enter regenerating temp. value.



Note!

Process temp. and regenerating temp. value are set between a certain limits. Process temp. should be set between 0 --200 and regenerating temp.

B. Four functional keys

Auto-start timer :

press this button to return back to previous menu.

Parameter setting :

To enter parameter setting menu. (Password is needed)

Alarm Display :

When the alarm of the system is activated, press this button to display alarm records.

Help :

Press this button to enter help menu.

3) Temperature parameters menu

Touch parameter setting button. Input user name: Shini, Input passwords 3588 Press "ENTER" button to confirm, and then "RETURN" key Return " dry monitor screen." Again by "parameter settings" button, you can enter the parameter settings.

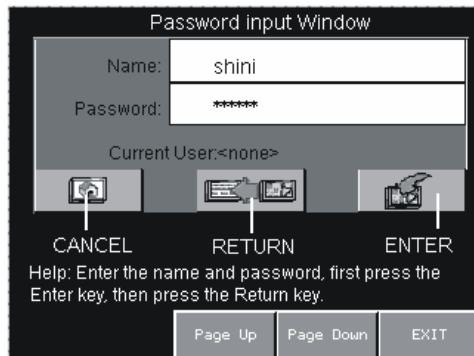

Picture 2-23 : Temperature Parameters Setting 1



Note!

Please keep this password securely and safely. If the password is missing, then the operator won't be able to log into the system parameter setup screen. It is better to preserve this password either by system administrator or senior operator.

After input correct password, the following menu appears.

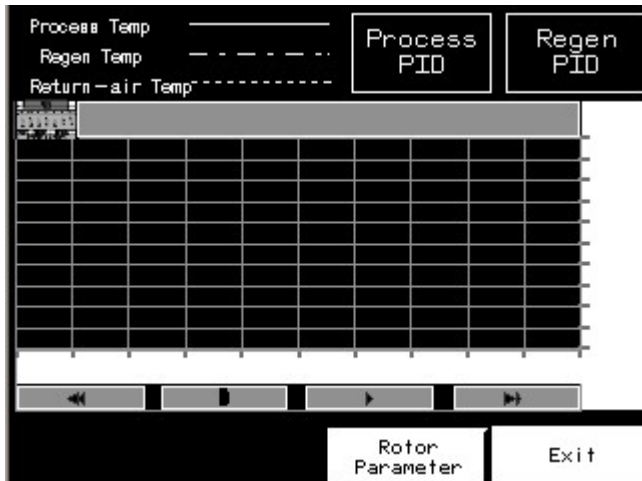

Picture 2-24 : Temperature Parameters Setting 2

A. Process temp. Parameters setting

Touch Process PID. , then the following menu appears. It includes proportion, integral, and derivative time.

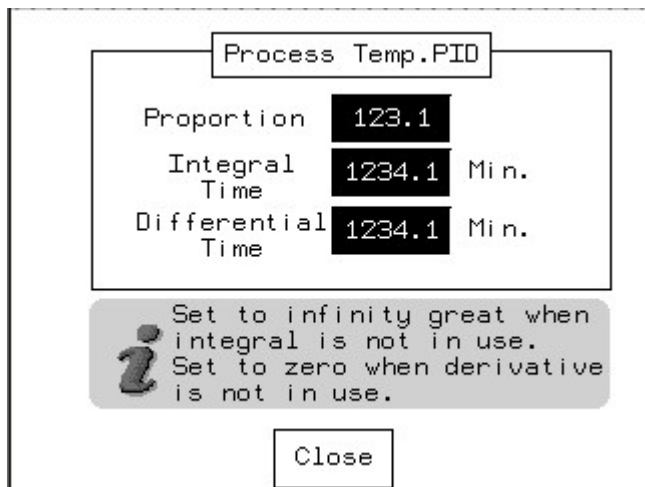

Picture 2-25 : Process temp. Parameters setting 1

When need to change one of the parameters, touch corresponding area, then a keypad appears. Input a value, press ENTER to confirm.

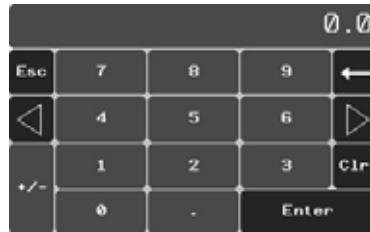

Picture 2-26 : Process temp. Parameters setting 2

Max. and Min. on the key-pad shows the Max. and Min. value of current parameter. If it is out of the limits, input value could not be confirmed by pressing ENTER.

If the system can not control the temp. Accurately, reset P.I.D parameters to gain more accurate temperature control.

Adjustment of Proportion (P)

Table 2-40 : Adjustment of Proportion (P)

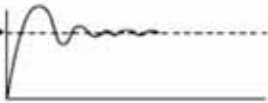
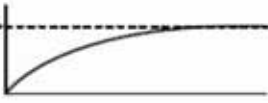
P increases		After the oscillation, the curve will be settled and back to setup point.
P decrease		The curve increases gradually in order to maintain a long reliable period against over oscillation.

Adjustment of Integral Time (I)

Table 2-41 : Adjustment of Integral Time (I)

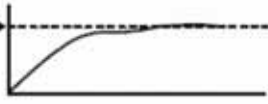
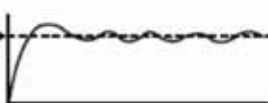
I increases		For default value requires a longer time for steady status. But, it still has over pulse/under pulse and oscillation occurs.
I decrease		After the occurrence of over pulse/under pulse and oscillation, but the curve tends to rise rapidly.

Adjustment of Differential Time (D)

Table 2-42 : Adjustment of Differential Time (D)

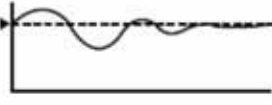
<p>D increases</p>		<p>Over pulse/under pulse and steady time become less, but the curve has small oscillation.</p>
<p>D decrease</p>		<p>Over pulse/under pulse increases, the duration for setup value requires certain time.</p>

B. Regenerating temp. Setting

Refer to the same setting procedures as for the "Process Temperature Control Parameter" by touching the Regen. P.I.D.

4) Rotor Speed Setting

By touching Rotor Parameter button at the button of Parameter Setting screen. The rotor speed parameter setting screen prompts as shown below: In SV field, can set "Rotor Speed Motoring Time". IN PV field, displays the cycle time for each rotation. When PV value is greater than SV value, the system will send out rotor speed error alarm message. Touching "More" button to retrieve details about rotor speed monitor help menu.

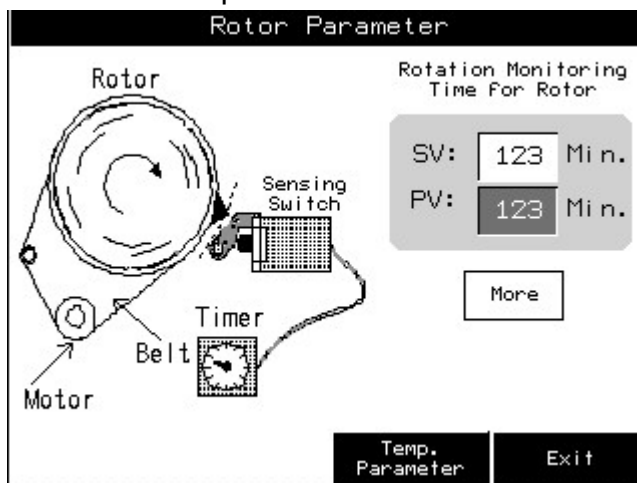

Picture 2-27 : Rotor Parameter Setting

5) Time Setting

By touching "Time Setting" button at the bottom of Parameter Setting screen in order to enter into Time Setting screen as shown below:

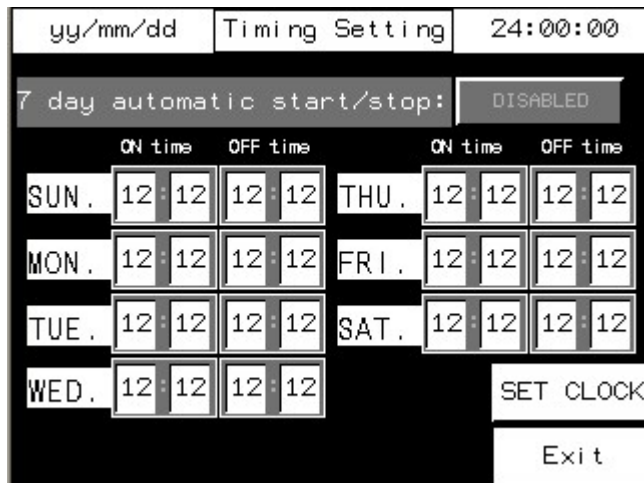

Picture 2-28 : Time Setting



Note !

The screen shows time 1 auto-start time only when delayed start-up function is enabled, and the screen shows time 2 extended cooling time only when the system is turned off.

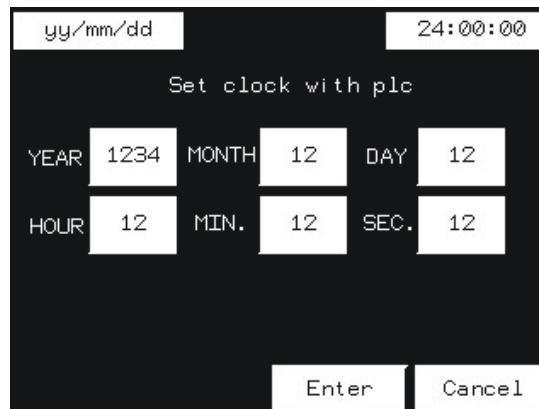

Picture 2-29 : Time Setting 2

Touch parameter setting menu. A numeric keypad will appear. Input each parameter and then press OK, a new setting come into effect. Press cancel to remove the setting.

6) Alarm Fault Records

By touching "Alarm Display" button under the bottom of "Drying Process" screen or Conveying Process" screen in order to enter into Alarm Fault Records screen as shown below:

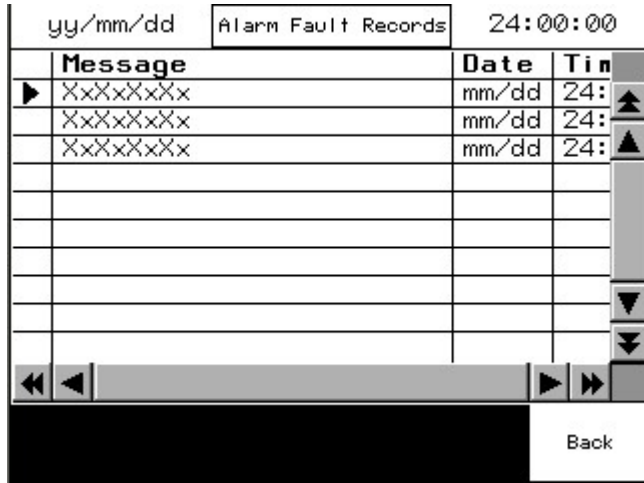

Picture 2-30 : Alarm Fault Records

1. When alarm fault records are more than displaying space, by touching "Up" or "Down" keys to review more records.
2. Touching record content, a help message is prompted. According to help message, the operator could get the troubleshooting information.
3. Press "EXIT" button to exit from this screen.
4. System Alarm Records Display

Table 2-43 : System Alarm Records Display

Alarm message	Results	Possible reasons
System reversed phase	The system can not be started, and flickering of red alarm light.	Voltage of power supply is too low, or phase shortage, or mistakes of phase sequence.
Process blower overload	Dryer and dehumidifier stop working, and flickering of red alarm light.	Voltage of power supply is too low, or blower problems, or mistakes of setting current.
Regenerating blower overload	Dryer and dehumidifier stop working, and flickering of red alarm light.	Voltage of power supply is too low, or blower problems, or mistakes of setting current.
Process over-heat	Dryer and dehumidifier stop working, and flickering of red alarm light.	Temp. control parameters mistakes, or contactor failures, or regenerating thermocouple problems.
Regenerating over-heat	Dryer and dehumidifier stop working, and flickering of red alarm light.	Temp. control parameters mistakes, or contactor failures, or regenerating thermocouple problems.

Alarm message	Results	Possible reasons
Return air over-heat	Dryer and dehumidifier stop working, and flickering of red alarm light.	Cooling water circulation problems.
Drying thermocouple break	Dryer and dehumidifier stop working, and flickering of red alarm light.	Thermocouple is not connected or poor connection or wrongly connected.
Regeneration thermocouple break	Dryer and dehumidifier stop working, and flickering of red alarm light.	Thermocouple is not connected or poor connection or wrongly connected.
Return air thermocouple break	Dryer and dehumidifier stop working, and flickering of red alarm light.	Thermocouple is not connected or poor connection or wrongly connected.
Rotor has no action.	Dryer and dehumidifier stop working, and flickering of red alarm light.	Motor is halted or burned out. Belt broken or damage of speed controller or parameter mistakes or rotor.
PLC is not in running mode.	The system can not work.	PLC was not set to RUN mode.

Note : 1) Overload Relay reset: Open control box, press "RESET" button on the corresponding overload relay.

2) Material Suction Alarm reset: Touch to turn the corresponding Hopper Receiver Selection switch into "OFF" and then turn it to "ON" again.

3) Rotor Speed Alarm reset: Touch to turn the Drying Switch to "OFF" and then turn it to "ON" again.

7) Help menu

Touch the help button to enter help menu. Press relative button to display details of each item.

HELP MENU

- OPERATION
- FEATURES
- WORKING PRINCIPLE
- SERVICE&MAINTENANCE
- EXIT SCREEN

Operation (1 of 5) [Page Down] [Exit]

1. Switch on the power supply and turn the main switch to on, the screen will show the initial menu. After touching the "English" key in the initial menu to enter into "Drying Process" menu, and then touch the drying switch to "ON", the drying process will begin to run.
2. Touch the "Regeneration Temperature" to enter a desired setting value via a numerical keypad to be hopped up.

Solution 1: [Next] [Exit]

Fault	Diagnosis	Remedy
Dew-point can not get to prospective value	The temperature of the return-air is too high	Check the cooling water temperature (low to 38°C be better)
	The rotate speed isn't proper	Adjust it
	The REGN. temperature isn't proper	Adjust it
Filter was blocked	Honeycomb was blocked	Clean or replace
	Honeycomb was blocked	Clean or replace
	Honeycomb has no action	Check motor, belt speed controller

Features 1: [Next] [Exit]

1. This system is applied for hygroscopic material used in the plastics industry such as PA,PC,PBT,PET etc.
2. The Dehumidified Drying Loader combines three station feeding, dehumidifier, and insulated drying hopper to form a compact design.
3. Using SIMENS PLC and temperature mode with PID controller, we can have a sophisticatedly control to temperature. They also have clock pre-warming, timing turn-off, auto start-up, overtemperature loading, phase reverse and honeycomb fails function.

Maintenance (1 of 2) [Page Up] [Page Down] [Exit]

1. Clean the process and regeneration filters at least once a week and install them properly, or it can reduce service life of the desiccant rotor.
2. Use only tap water for the cooling propose, never use chilled water.
3. Clean the after-cooler at least once every two weeks.
4. Check all the electrical component regularly.
5. Clean the desiccant rotor three times a year.
6. Clean the desiccant rotor with normal detergent water, but drying of the rotor can only be carried out by nature ambient air. NEVER dry it by the

WORKING PRINCIPLE

Picture 2-31 : Help menu

Press on the temp. controller for at least 3 seconds to enter into initial setting screen. Press until it displays SL-H (temp. upper limit). Change the value of it by up and down arrow. Press again to set the value of SL-L (lower limit) by up and down arrow. For example, if you are trying to set temp. limits among 60-80 , just set the value of SL-L and SL-H at 60 and 80 respectively.

2.9.4 Dew-point Monitor

1. Embedded Dew-point Monitor

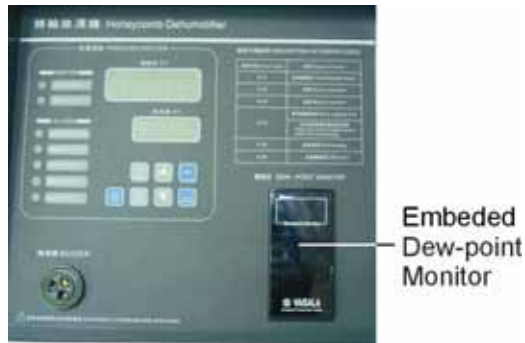

Picture 2-32 : Embedded Dew-point Monitor

2. Detachable Dew-point Monitor



Picture 2-33 : Detachable Dew-point Monitor

3. Installation Testing

3.1 Attention

- 1) Make sure voltage and frequency of the power source comply with those indicated on the manufacturer nameplate, which is attached to the machine.
- 2) Power cable and earth connections should conform to your local regulations.
- 3) Use independent power cable and ON/OFF switch. The cable's size should not smaller than those wired in the electrical requirement of control panel.
- 4) The power cable connection terminals should be tightened securely.
- 5) The machine requires a 3-phase 4-wire power source, connect the power lead (L1, L2, L3) to the live wires, and the earth (PE) to the ground.
- 6) Power supply requirements:
Main power voltage: $\pm 5\%$
Main power frequency: $\pm 5\%$
- 7) The cooling water pressure is $3\sim 5 \text{ kgf/cm}^2$, the pressure gap between the inlet water and the outlet water is $3\sim 5 \text{ kgf/cm}^2$, and the cooling water temperature is $10\sim 30$.
- 8) Refer to the electrical wiring diagram to complete the electrical installation.

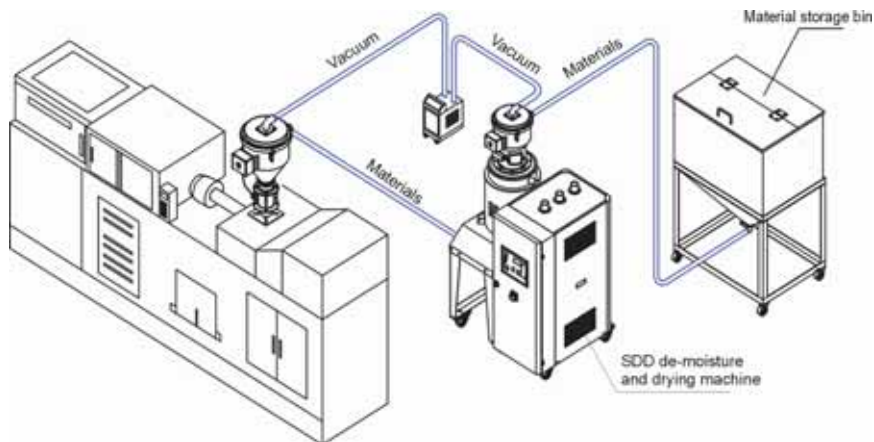

Picture 3-1 : Installation Drawing



Notes!

Keep the machine 2m from the combustible distance.

3.2 Honeycomb-rotor

3.2.1 What is Honeycomb-rotor

The main body of the honeycomb-rotor is a honeycomb, made by ceramic fibre and organic additives, sintered under high temperature with molecular sieve and silica gel, to be strongly bonded together and form a solid and hard surface. Not like common molecular sieve, which will produce dusts and fines to pollute raw materials when aging or become saturated requiring regular replacement, honeycomb-rotor offer unlimited long life and can be cleaned when it is polluted. The moisture of return air is quickly absorbed by numerous tunnels before coming out of the rotor to form low dew-point air. At the same time, regenerating blower takes dry air into the honeycomb-rotor from an opposite direction to regenerate the rotor.



Picture 3-2 : Honeycomb Rotor

3.2.2 Installation of the Rotor

- 1) The upper and lower lid of honey-comb should install Teflon gasket (Fig. 1).
- 2) Use 4 screws to fix the rotor base on the machine frame firmly, and then install the shaft accordingly (Fig. 2).
- 3) Install the gearmotor and transmission gear (Fig. 4).
- 4) Install and fix the main support screws (Fig. 3).
- 5) Fit the transmission belt in proper position (Fig. 6).
- 6) Install the honeycomb-rotor (Fig. 9) and transmission belt (Fig. 12).
- 7) Fix the rotor top cover (Fig. 8).
- 8) Fit all springs and tighten the screws (Fig. 7).

- 9) Install both the transmission belt (Fig. 13) and belt tension regulator (Fig. 14).
- 10) Install micro-switch and fixed board firmly (Fig. 10).



Picture 3-3 : Installation of the Rotor

3.3 Heater Assemblies

- 1) Install the heating pipe in the heater.
- 2) Fix the heater into the housing. (See right picture)



Warning!

Hot surfaces could burn hands. Take care of high temperature!
This label should be stick to the shell of heater.



1



2



Picture 3-4 : Heater Assemblies

3.3.1 EGO



The EGO value has been setting before out factory, Don't modify it.



Picture 3-5 : EGO

4. Operating

4.1 Control Panel



Picture 4-1 : Control Panel

Table 4-1 : Control Panel Table

No.	Name	Function description	Remarks
1	Running indicating	Indicates the working status of blower and heater	Green light on indicates working status Green light off indicates stop status
2	Fault indicating	Indicates current alarm message	Red light on indicates fault occurs
3	Time start	Set weekly start or intermittent start/stop	When time has been set, press this key to set time start mode
4	Temp/time shift key	Display alternatively in between temp. And time for temp or time set up	
5	Start/stop key	Control the start and stop of the machine	Press to start at stop status. Press to stop at working status.
6	Real value indicated by LED	Display real drying temperature or parameter code	
7	Set value indicated by LED	Display the set drying temperature	
8	Increase set value	Increase set value	
9	Set key	Enter or exit value setting	
10	Confirm key	Confirm the input of data	
11	Decrease set value	Decrease the set value	
12	Buzzer	Buzzer keeps on when fault exists.	Buzzer only silence after trouble shooting
13	Dew-point	Dewpoint display	Display real timely the moisture content within the material

4.2 Panel Operation

- 1) Open the main switch.
- 2) Press "RUN/STOP" key to start loading.

4.3 Temperature Setup

- 1) The setup number will flicker after pressing "SET" key, add or decrease temperature by pressing ▲▼ key.
- 2) Press "ENTER" key to confirm the input value.

4.4 PID Auto-tuning Setting

- 1) Press "SET" and the digits flash. At this time press "SET" and "Enter" meanwhile for 1.5 seconds to enter auto-tuning mode. Then two values of "At" and "Present temperature" will display alternatively in PV and the set temperature value displays in SV till auto-tuning is finished. After that, system goes back to the normal operation directly.
- 2) If auto-tuning setting could not be finished within 1 hour, the parameters will not be altered and system goes back to normal operation.
- 3) Pressing "ON/OFF" to go back normal operation amid automatic calculation would not alter the original parameters.

4.5 Intermittent Running Setup

Drying periods(0-ON)

Stop periods(0-OFF)

- 1) Press "SET" key to change temp. setup value into time setup value , press "TEMP/TIMER" key to enter into setup mode, at this time "SV/setup value" flickers , "PV/setup value" displays "0-ON".



Picture 4-2 : Intermittent running setup 1

- 2) PV displays "0-ON" to stand for drying periods. "0-OFF" stands for machine

stop time. Press ▲▼ key to add or decrease time value of "SV/setup value". Each press of ▲▼ can add or decrease 15 mins set time.

- 3) Press "ENTER" to confirm the input time value and enter into "0-OFF" time setup items, then repeat step 2.



Picture 4-3 : Intermittent running setup 2

Note : If set 0-ON as 04:00, 0-OFF as 05:00, which means drying periods is 4 hours stop time is 5 hours , then working for 4 hours and being stopped for 5 hours and repeat this so long.

- 4) Cancel intermittent running by entering 00.00 at "0-ON" or "0-OFF" press "ENTER" to confirm input value after time setup and enter into time setup items from "1-ON" "week-ON".



Picture 4-4 : Intermittent running setup 3

4.6 Weekly Time Start Setup

- 1) Press ▲▼ key to add or decrease the time value in "SV/setup value " from "1-ON". Press "ENTER" to confirm the input value and comes into the time setup items of "1-OFF" "MON-OFF".



Picture 4-5 : Weekly Time Start Setup 1

- 2) Press ▲▼ key to add or decrease the time value in "SV/setup value " from "1-OFF" . Press "ENTER" to confirm the input value and comes into the time setup items of "2-ON""TUE-ON".



Picture 4-6 : Weekly Time Start Setup 2



- 3) Do the same setup again and again to setup the ON/OFF time from Monday to Sunday.



Picture 4-7 : Weekly Time Start Setup 3



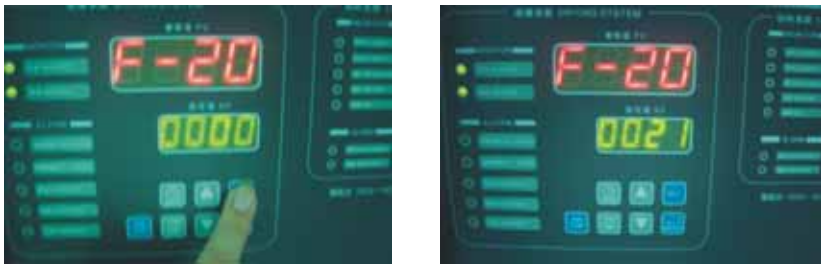

- 4) Press "SET" key to back to normal status, after finish all the setup.
- 5) Setup all the "ON" to 00:00 if it is not for time start/stop.

Note:

1. F-20 functions as an password lock , hold on "SET" till the "PV" displays F-20.
2. Press   key and only after input 0021 in the SV , can you press "ENTER" to come into F-03 and other settings , so F-20 functions as an passwordlock for entering into next parameters setup, which prevents the modification from unprofessionals.



Picture 4-8 : Weekly Time Start Setup 4

3. F-03 stands for the selection of temperature unit. Press   to shift between / then press "ENTER" to confirm.
4. F-04 is data lockup function, press   key to shift between OFF / LOCK , LOCK is for locking up information , not able to input or change any data: OFF is for lockup cancellation.



Picture 4-9 : Weekly Time Start Setup 5

5. F-05 stands for the function of temperature protection. Alarm will be launched if actual temperature were equal to or higher than the addition of setting temperature value and setting value. This temperature range is between 0 to 50, and default value is 15.

4.7 Present Time Modification

- 1) Repeat the above steps until PV displays "TIME" to stand for present time.
- 2) Press ▲▼ key to add or decrease time.
- 3) Press "ENTER" key and PV displays "DAY" to stand for week days.
- 4) Press ▲▼ key to add or decrease days.
- 5) Press "SET" key to back to normal status after finish all the setup.

4.8 Weekly Time Start

- 1) Activate the weekly time start after finish the time setup and the present time setup.
- 2) Press "AUTO" key at working or stop status to preset the time start/stop, the "PV" will display the time and temp. alternatively.
- 3) Press "AUTO" again if want to cancel that weekly time setup.

4.9 Lock Setup Way

- 1) Press "SET" key down and release it till "PV" displays F-20.
- 2) Press ▲▼ key to make "SV" to 0021, then press "ENTER" key , the "PV" will display F-04.
- 3) F-04 are for LOCK function selection , press ▲▼ key to select LOCK or OFF.
- 4) Press ENTER or "SET" key after setup.
- 5) If select LOCK , the "SV" will display "LOCK" when pressing "SET" key, which means the parameters have been setup and not accessible to any change.

4.10 The second level of Advanced Setting

- 1) Enter the first level of advanced setting and press "SET" and "Enter" meanwhile for 3 seconds till F-06 displays in PV..
- 2) Press ▲▼ to set SV into 0003 and press "Enter", at this time F-06 displays in PV.
- 3) Now pressing ▲▼ can alter value, press "Enter" to input after confirming then jump to F-07.
- 4) If you want to leave the function setting, just press "SET".
 1. F-06 stands for the passwords of second level.
 2. F-07 stands for proportional band of heating side (P); it is a preset value before delivery.
 3. F-08 stands for integration time of heating side (I); it is a preset value before

delivery.

4. F-09 stands for differential time of heating side (D); it is a preset value before delivery.
5. F-10 stands for switch cycle of heating side; its preset value is 15 sec.
6. F-16 stands for power deliver delay time of heater, it is adjustable, the unit is Sec..
7. F-17 stands for blower power-off delay time, it is adjustable, the unit is Sec..
8. F-18 stands for the protection of maximum temperature. Its setting range is 140~250.
9. F-19 stands for microswitch timeset of honeycomb rotor. "OFF" functions as shut-off and "ON" functions as open. The setting range is 0~9999 with the unit is Sec..

4.11 Wrong Codes Remark

Table 4-2 : Wrong Codes Remark

Wrong codes	Remark
E-01	Break of temperature-sensed line
E-02	Inverse phase
E-03	Overload input
E-04	Overheat input for drying EGO
E-05	Maximum temperature protection
E-07	Thermal protection temperature
E-08	Memory errors
E-09	Rotor Microswitch input
E-10	Overheat input for regenerative EGO
E-11	Reversed-phase of temperature sensed line
E-12	Auto-tuning errors

4.12 Installation for Dewpoint Monitor

- 1) Use blade to cut off the film and outline the reserved hole site on the SCD control panel.



Picture 4-10 : Hole Site

2) Check if there are complete parts for dewpoint monitor including:

Dew-point monitor

Dew-point transmitter assembly (dew-point detector, detection cable, washer and installation guide)

Copper joint, installation seat for dew-point monitor



Picture 4-11 : Parts of Dew-point Monitor

3) Dismantle the copper joint of original machine and replace it with installation seat for dew-point monitor. Then dismantle straight form bushing from copper joint of original machine and install it on the installation seat, and connect copper pipe with straight form bushing.



Copper Joint Assembly of Original Machine

Picture 4-12 : Copper Joint Assembly of Original Machine



Picture 4-13 : Installation Seat

4) Install dew-point transmitter assembly to copper joint.



Picture 4-14 : Installation for Transmitter

5) Connect signal wire. Particular shape of signal wire joint would avoid the wrong insert and connection.



Picture 4-15 : Connection of Signal Wire

6) Match dew-point monitor with holes on the panel and fix the installation.



Picture 4-16 : Installation for Dew-point Monitor

7) Connect signal wires of the transmitter and power lines of dew-point monitor with the according terminals.

Connet contact No.1 and No.2 with power, supply is 220VAC.

Contact No.3, No.4 and No.5 are idle.

Connect contact No.6, No.7 and No.8 with the signal of transmitter. (C- Connects contact No.6, C+ connects contact No.7 and wire No.9 connects contact No.8.

Transmitter conection (White and blue wire connect wire No9, black wire connect C- and gray wire connect C+)

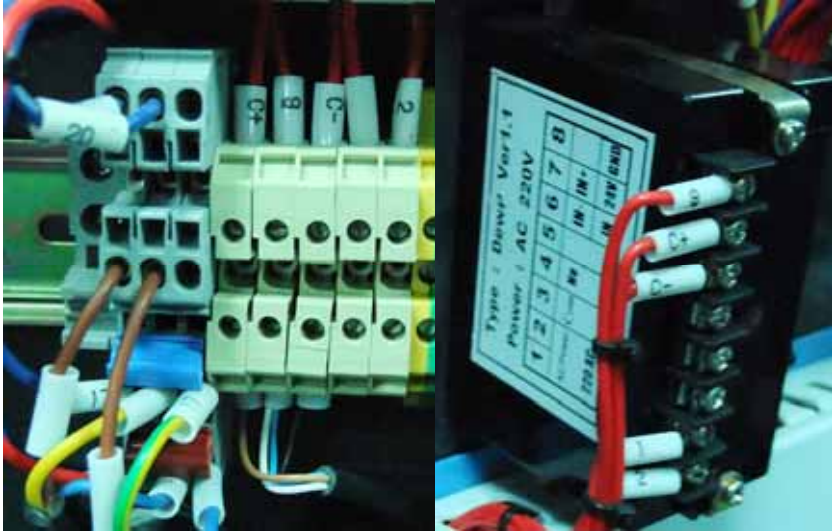

Picture 4-17 : Connection of Dew-point Monitor

5. Trouble-shooting

Symptom	Possible causes	Actions taken
Main power indicator does not shine after turn on main power switch.	<ol style="list-style-type: none"> Does not connect through power supply. Main power switch problems. Problems of electrical wires. Fuse of control circuit melted. Transformer problems. 	<ol style="list-style-type: none"> Connect through power supply. Replace main power switch. Check electrical wires. Check electrical wires and replace fuse. Replace the transformer.
E-02 is shown at PV, buzzer sounds and machine stops.	<ol style="list-style-type: none"> Voltage of power supply is too low. Phase shortage. Phase frequency mistakes. 	<ol style="list-style-type: none"> Check the power supply. Check the power supply. Exchange the connection of two of the electrical wires.
Overload alarm of blower is lit up.	<ol style="list-style-type: none"> Abnormal fluctuation of voltage. Blower being stalled. Failures of blower motor. Setting current of overload relay (F1) is too low. 	<ol style="list-style-type: none"> Check power supply. Check the blower. Check the motor. <p>Set the current of overload relay 1.1 times of rated current of the motor. Referring to 10-4 for more information of overload relay. Reset overload relay: press down the blue button on the relay after 1 minutes.</p>
Pipe heater overheat alarm is lit up, and the buzzer sounds and machine stops working.	<ol style="list-style-type: none"> Temperature setting mistakes. Temp. measuring mistakes. Overheat relay of pipe heater failures. 	<ol style="list-style-type: none"> Correctly set the parameters of temp. Controller. Replace thermocouple. Replace the contactor.
E-04 is shown at PV, buzzer sounds and machine stops	<ol style="list-style-type: none"> Heater contactor seized up. EGO parameter setting wrong. EGO fault. Circuit fault. 	<ol style="list-style-type: none"> Check or replace the heater contactor. Set EGO parameter correctly. Replace EGO. Check circuit.
E-04 is shown at PV, buzzer sounds and machine stops	<ol style="list-style-type: none"> Problems of rotor motor. Rotor belt broken. Problems of electrical circuit. Microswitch of the rotor failures. Parameter mistakes of timer for control of rotor. 	<ol style="list-style-type: none"> Check or replace the motor. Replace the belt. Check the electrical circuit. Replace. Reset the timer. (Set time should be bigger than rotor rotating time in one turn and plus 1 minute.)

6. Maintenance and Repair

6.1 Honeycomb-rotor

6.1.1 H Model of Honeycomb-rotor

(Final material moisture content can be as low as 0.004% or less)

- 1) Put the rotor in a ventilated space and let it cold down to normal temperature naturally.
- 2) Use compressed air to clean the dust inside the rotor.
- 3) Pre-mix the water and detergent in the ratio of 20:1 to form a water solution.
- 4) Sink the rotor in the water solution for about 4 to 6 hours until the oil and contaminations decomposed in the detergent.
- 5) Rotor must be washed with clean water until the detergent is completely cleaned.
- 6) Use compressed air to spray water remains inside the rotor away.
- 7) After 4 to 6 hours later, put the rotor under the moderate sunlight for one day.
- 8) Install the rotor back to the dehumidifier, and set the regenerating temperature to 60 °C in order to dry the rotor for 4 hours. (Note: Do not dry the rotor with high temperature. It will make water molecule expand rapidly inside the rotor and cause serious rotor damage.)
- 9) After that, in turn set the regenerating temperature to 200 °C in order to dry the rotor fully for another 4 hours.
- 10) Set the regenerating temperature to the default temperature (that is 180 °C).
- 11) Cleaning procedures are completed.



Note!

Please note that some dirt, like oil mist or other types of sticky mist, is almost impossible to clean out effectively so the rotor may not be cleaned effectively and has to be replaced. This may be happened if it is polluted by exhaust gas of machines driven by diesel oil. After cleaning, the dehumidifying capacity of the rotor may be as good as before, but usually it would be affected. If you need special service for cleaning the rotor, feel free to contact us.

6.2 Filter

Please periodically clean the dust on the air filters, once per week.

Cleaning steps :

- 1) Take out the air filter carefully.
- 2) Blow off the dust on the air filter screen and the cover with pressure air.
- 3) Wipe off the barrel wall of air filter with dishcloth.
- 4) After cleaning, place all parts in reversed order carefully.



Picture 6-1 : Filter



Note!

Don't make sundries fall into the barrel, when taking out the air filter.

6.2.1 The Useful Life of the Key Parts of the Product

Table 6-1 : The Useful Life of the Key Parts of the Product

Name of the parts	Useful life
Blower	Above 5 years
Process heater	Above 1 year
Regen. heater	Above 1 year
Contactora	Above 100,000 act
Honeycomb	5~10 years

6.3 Cooler Clear Step

- 1) Disassemble the cooler's pipe and screw, and remove the cooler out of the chiller.
- 2) Release the fixed screw on the upper and lower cover of cooler and disassemble the cover.
- 3) Use brushes, compressed air or low pressure water to clean the dust and sundries on the cooler fan and copper pipe. Notes: water residue on the cooler fan and copper pipe should be dried with compressed air.
- 4) Make the cooler's upper and lower cover junction clean enough and smear the silica gel then fixed the covers with screws.
- 5) Put the cooler on the air at least 4 hours to make the silica gel drying enough then fix the cooler on the chiller and connect all pipes.

6.4 Maintenance Schedule

6.4.1 General Machine Information

Model _____ SN _____ Manufacture date _____

Voltage _____ Φ _____ V Frequency _____ Hz Power _____ kW

6.4.2 Check After Installation

- Check that the conveying pipes are tightly locked.
- Check that the material clearance door is firmly closed.
- Check that the conveying pipes are correctly connected.
- Check if there are damages of honeycomb-rotor.

Electrical Installatio

- Voltage: _____ V _____ Hz
- Fuse melt current : 1 Phase _____ A 3 Phases _____ A
- Check the phase frequency of power supply.
- Check rotating direction of regenerating motor.
- Check rotating direction of conveying blower fans.

Check air supply of compressor

- Compressed air pressure _____ bar
- Air flow _____ L/nun
- Check if the compressed air purified or not

6.4.3 Daily Checking

____ / ____ / ____

- Check the switch of the machine.
- Check auto start-up of the machine.

____ / ____ / ____

- Check the switch of the machine.
- Check auto start-up of the machine.

____ / ____ / ____

- Check the switch of the machine.
- Check auto start-up of the machine.

____ / ____ / ____

- Check the switch of the machine.
- Check auto start-up of the machine.

____ / ____ / ____

- Check the switch of the machine.
- Check auto start-up of the machine.

____ / ____ / ____

- Check the switch of the machine.
- Check auto start-up of the machine.

____ / ____ / ____

- Check the switch of the machine.
- Check auto start-up of the machine.

____ / ____ / ____

- Check the switch of the machine.
- Check auto start-up of the machine.

____ / ____ / ____

- Check the switch of the machine.
- Check auto start-up of the machine.

____ / ____ / ____

- Check the switch of the machine.
- Check auto start-up of the machine.

____ / ____ / ____

- Check the switch of the machine.
- Check auto start-up of the machine.

____ / ____ / ____

- Check the switch of the machine.
- Check auto start-up of the machine.

____ / ____ / ____

- Check the switch of the machine.
- Check auto start-up of the machine.

____ / ____ / ____

- Check the switch of the machine.
- Check auto start-up of the machine.

____ / ____ / ____

- Check the switch of the machine.
- Check auto start-up of the machine.

____ / ____ / ____

- Check the switch of the machine.
- Check auto start-up of the machine.

____ / ____ / ____

- Check the switch of the machine.
- Check auto start-up of the machine.

____ / ____ / ____

- Check the switch of the machine.
- Check auto start-up of the machine.

6.4.4 Weekly Checking

/ /

- Check the switches of the machine
- Check all the electrical wires
- Check if there are loose electrical connections
- Check and clean air filter
- Check and maintain compressed-air filter and regulator
- Check solenoid valve
- Check motor overload relay and anti-phase function

/ /

- Check the switches of the machine
- Check all the electrical wires
- Check if there are loose electrical connections
- Check and clean air filter
- Check and maintain compressed-air filter and regulator
- Check solenoid valve
- Check motor overload relay and anti-phase function

/ /

- Check the switches of the machine
- Check all the electrical wires
- Check if there are loose electrical connections
- Check and clean air filter
- Check and maintain compressed-air filter and regulator
- Check solenoid valve
- Check motor overload relay and anti-phase function

/ /

- Check the switches of the machine
- Check all the electrical wires
- Check if there are loose electrical connections
- Check and clean air filter
- Check and maintain compressed-air filter and regulator
- Check solenoid valve
- Check motor overload relay and anti-phase function

/ /

- Check the switches of the machine
- Check all the electrical wires
- Check if there are loose electrical connections
- Check and clean air filter
- Check and maintain compressed-air filter and regulator
- Check solenoid valve
- Check motor overload relay and anti-phase function

/ /

- Check the switches of the machine
- Check all the electrical wires
- Check if there are loose electrical connections
- Check and clean air filter
- Check and maintain compressed-air filter and regulator
- Check solenoid valve
- Check motor overload relay and anti-phase function

/ /

- Check the switches of the machine
- Check all the electrical wires
- Check if there are loose electrical connections
- Check and clean air filter
- Check and maintain compressed-air filter and regulator
- Check solenoid valve
- Check motor overload relay and anti-phase function

/ /

- Check the switches of the machine
- Check all the electrical wires
- Check if there are loose electrical connections
- Check and clean air filter
- Check and maintain compressed-air filter and regulator
- Check solenoid valve
- Check motor overload relay and anti-phase function

6.4.5 Monthly Checking

____ / ____ / ____

- Check if transmission belt is loose or not
- Check the status of gear motor performance
- Check if there is leakage in the rotor

____ / ____ / ____

- Check if transmission belt is loose or not
- Check the status of gear motor performance
- Check if there is leakage in the rotor

____ / ____ / ____

- Check if transmission belt is loose or not
- Check the status of gear motor performance
- Check if there is leakage in the rotor

____ / ____ / ____

- Check if transmission belt is loose or not
- Check the status of gear motor performance
- Check if there is leakage in the rotor

____ / ____ / ____

- Check if transmission belt is loose or not
- Check the status of gear motor performance
- Check if there is leakage in the rotor

____ / ____ / ____

- Check if transmission belt is loose or not
- Check the status of gear motor performance
- Check if there is leakage in the rotor

____ / ____ / ____

- Check if transmission belt is loose or not
- Check the status of gear motor performance
- Check if there is leakage in the rotor

____ / ____ / ____

- Check if transmission belt is loose or not
- Check the status of gear motor performance
- Check if there is leakage in the rotor

6.4.6 Half-yearly Checking

____ / ____ / ____

- Check if there are damages of conveying pipe
- Check the pipe heater
- Check regenerating/conveying blower and fans of the motor

____ / ____ / ____

- Check if there are damages of conveying pipe
- Check the pipe heater
- Check regenerating/conveying blower and fans of the motor

____ / ____ / ____

- Check if there are damages of conveying pipe
- Check the pipe heater
- Check regenerating/conveying blower and fans of the motor

____ / ____ / ____

- Check if there are damages of conveying pipe
- Check the pipe heater
- Check regenerating/conveying blower and fans of the motor

____ / ____ / ____

- Check if there are damages of conveying pipe
- Check the pipe heater
- Check regenerating/conveying blower and fans of the motor

____ / ____ / ____

- Check if there are damages of conveying pipe
- Check the pipe heater
- Check regenerating/conveying blower and fans of the motor

____ / ____ / ____

- Check if there are damages of conveying pipe
- Check the pipe heater
- Check regenerating/conveying blower and fans of the motor