

52	YW64000800100	Hex metal insert hex. lock nut GB/T889.11#		1	option
51	YW64080600000	Hex. nut GB/T6170 M8-Longzine		1	option
50	YW60082500100	Hex bolt GB/T5781 M6x5-8-Longzine		1	option
49	YW661224.00000	Flat washer A grade GB/T9111 1035x2x2.5-Longzine		8	option

48	YW65012000000	Standard spring washer GB/T918-Longzine		4	option
47	YW60124500000	Hex. bolt GB/T5781 M6x6-8-Longzine		4	option
46	YW60081600100	Hex. bolt GB/T5781 M6x6-4.8-Longzine		4	option
45	YW66641216000	Flat washer A grade GB/T917.1.6-Longzine		4	option
44	YW65006000100	Standard spring washer GB/T918-Longzine		4	option
43	YW61062001200	Inner hex. column head screw GB/T7111 M6x2.5-Longzine		4	option
42	YW03000300200	Movable castor 3"	assembly	1	option
41	YW02000200000	Stainless steel pipe clamp 2"	SUS201	2	option
40	YR60105000200	Steel wire plastic pipe 15"		1	option
39	BH10162000010	Hinge base pin	Q235A	1	option
38	BL59160000821	Hinge base	Q235A	1	option
37	BM30552300050	Blower 0.55kW	assembly	1	option
36	BL50240200020	Blower fixed plate	assembly	1	option
35	YW66061300000	Flat washer A grade GB/T9111 6.6x6x2.5-Longzine		2	
34	YW65006000100	Standard spring washer GB/T918-Longzine		2	
33	YW61061200000	Inner hex. column head screw GB/T7111 M6x2.5-Longzine		2	
32	BL510024.01220	Sensor fixed plate	SPCC3.0	1	
31	YW68005500000	Inner hex. flat end lock screw GB/T7711 M6-Longzine		3	
30	BH1124.1000010	Screw lock nut	4	3	
29	YW61082001200	Inner hex. column head screw GB/T7111 M6x2.5-Longzine		4	option
28	YW66081900000	Flat washer 8x19x2.0-Longzine		10	option
27	YM10572.1000500	Gear motor SKS72.1-80LH/4	assembly	1	
26	YW61123500000	Inner hex. column head screw GB/T7111 M6x2.5-Longzine		8	
25	--	Gear motor mount base	SPH8.0	1	
24	YW65008000100	Standard spring washer GB/T918-Longzine		10	option
23	--	Shaft coupler cover plate	SPCC2.0	1	
22	YW03000300900	USA slide brake black castor 3"	assembly	2	
21	YW661224.00000	Flat washer A grade GB/T9111 1035x2x2.5-Longzine		12	
20	YW65012000000	Standard spring washer GB/T918-Longzine		12	
19	YW61122500000	Inner hex. column head screw GB/T7111 M6x2.5-Longzine		4	
18	YW61082001200	Inner hex. column head screw GB/T7111 M6x2.5-Longzine		4	
17	--	Control box assembly	Welding parts	1	
16	--	Feed case assembly	assembly	1	
15	YW61081600000	Inner hex. column head screw GB/T7111 M6x2.5-Longzine		10	
14	BL560024.00020	Safety switch fixed plate	SPH8.0	1	
13	BH10184.900010	Feed bar rotating shaft	Q235A	2	
12	--	Cutting chamber assembly	assembly	1	
11	--	Cyline assembly	assembly	1	option
10	YW64012100000	Hex. nut GB/T6170 M12-Longzine		3	
9	YW661224.00000	Flat washer A grade GB/T9111 1035x2x2.5-Longzine		3	
8	BH5624.0200010	Star assembly	assembly	3	
7	--	Section pipe	SUS201(1.0)	1	
6	--	Storage bin	Welding parts	1	
5	--	Base assembly	Welding parts	1	
4	YW66081900000	Flat washer 8x19x2.0-Longzine		30	
3	YW65008000200	Standard spring washer GB/T918-Longzine		30	
2	YW60081600100	Hex. bolt GB/T5781 M6x16-4.8-Longzine		16	
1	YW03000300500	USA flat plate fixed black castor 3"	assembly	2	

制图	版号	标题	SG-24.17N	图号		比例		数量	
设计	核准	齿啮式粉碎机		材质					
校对	日期	SHINI 信易电热机械股份有限公司 Shini Plastics Technologies, Inc.		表面要求					
标记	更改前	更改后	更改人	日期	审核	日期	物料号		

weight (kg)	Noise when granulating dB(A)	Max. cutting ability (kg/hr)	Cutting Ability Size (mm)	Small Teeth Cutter Qty	Big Teeth Cutter Qty	Teeth Cutter Qty	Staggered Cutter Qty	Teeth Cutter Mat.	Main Shaft Speed (r.p.m)	Motor Power (KW)	Version No.
215	80-85	3.5	240×175			2	1	SKD11	27	0.75	VER.E

- Note:1) The max. cutting ability depends on the granule's size and property;
 2) The noise during crushing varies according to the granules property and motor;
 3) SKD11 meets the JIS standard No.;
 4) Standard slant teeth cutters, narrow and widened slant teeth cutters are options;
 5) In order to avoid sticking the plastic cutter, all materials to be crushed shall be processed at normal temperature;
 6) Machine Power: 3ø, 400VAC, 50Hz;

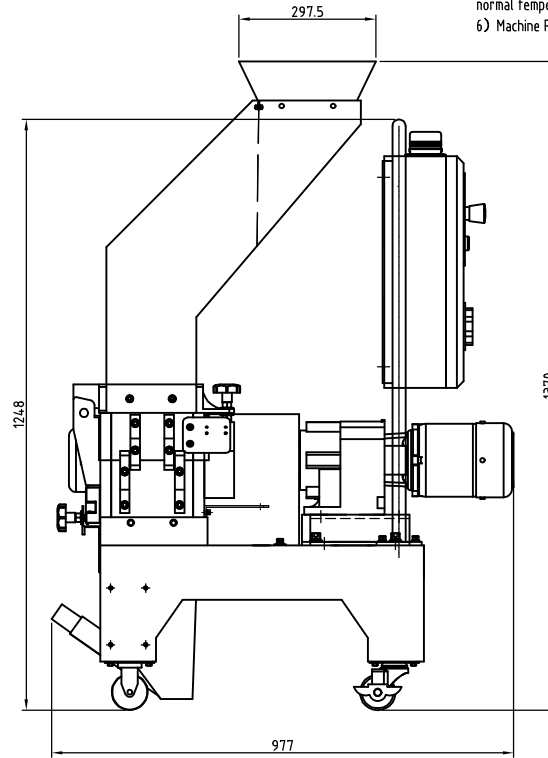
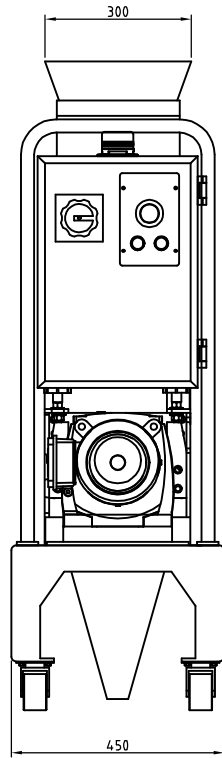

					制图	版号	标题	图号	比例	数量
					设计	核	齿槽式粉碎机			材质
					校对	准	信易電熱機械股份有限公司 Shini Plastics Technologies, Inc.	表面要求		
标记	更改前	更改后	更改人	日期	审核	日期		物料号		

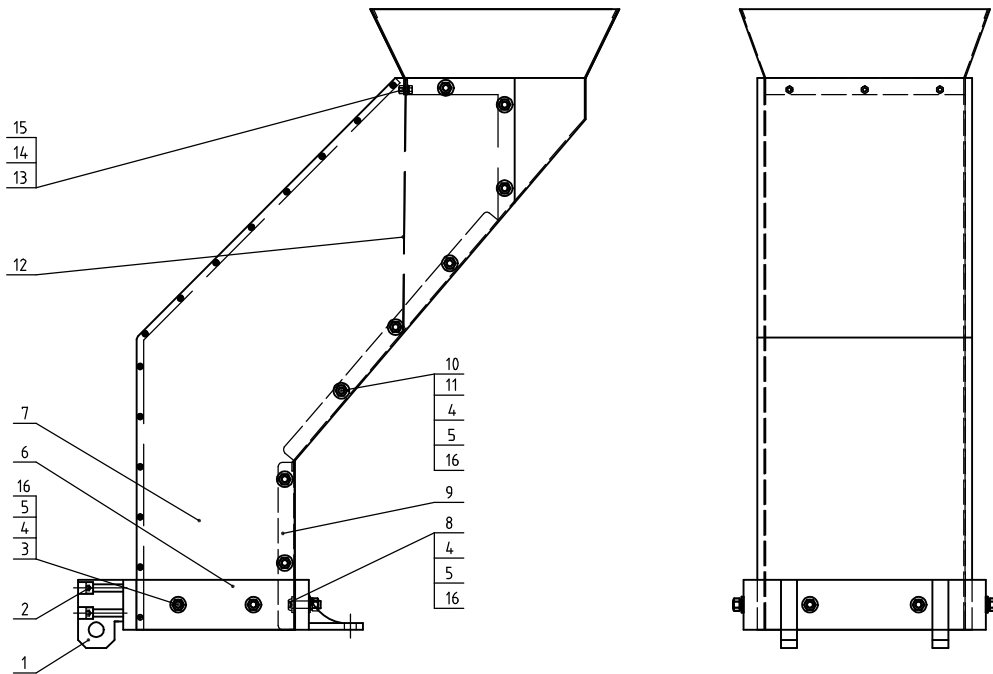

16	YW6500800100	Standard spring washer Ø11.5x4-Longzine		24	
15	YW62041000000	Large recessed flat head screw JS 100MMx10-Longzine		3	
14	YW64040700100	Non-metal insert hex. lock nut GB/T889.11M		3	
13	--	Fender pressing plate	SPCC1.5	1	
12	--	Material fender	with waterproof cloth	1	
11	YW61082500200	Inter hex. flat head screw Ø7.7x10x5-43-Longzine		16	
10	--	Feed part	SPCC1.5	1	
9	--	Feed box rear lower plate	SECC2.0	1	
8	YW61083500100	Inter hex. flat head screw Ø7.7x10x5-43-Longzine		2	
7	BR90242700110	Feed box	Assembly	1	
6	--	Feed box lower base	Assembly	1	
5	YW64000800100	Non-metal insert hex. lock nut GB/T889.11M		24	
4	YW66081900000	Flat washer 8x19x2.0-Longzine		32	
3	YW61084000100	Inter hex. flat head screw Ø7.7x10x4-43-Longzine		6	
2	YW61085000000	Inter hex. round head screw Ø7.7x10x5-43-Longzine		4	
1	BH10241300110	Feed box rotating block I	Q235A	2	
序号	代号	名称	材料	数量	备注

					制图	版号	标题	图号	比例	数量
					设计	核准	SG-24.17N		1:1	2
					校对		进料箱总成		表面要求	材质
					审核	日期	SHINI 信易電熱機械股份有限公司 Shini Plastics Technologies, Inc.		物料号	
标记	更改前	更改后	更改人	日期	审核	日期				

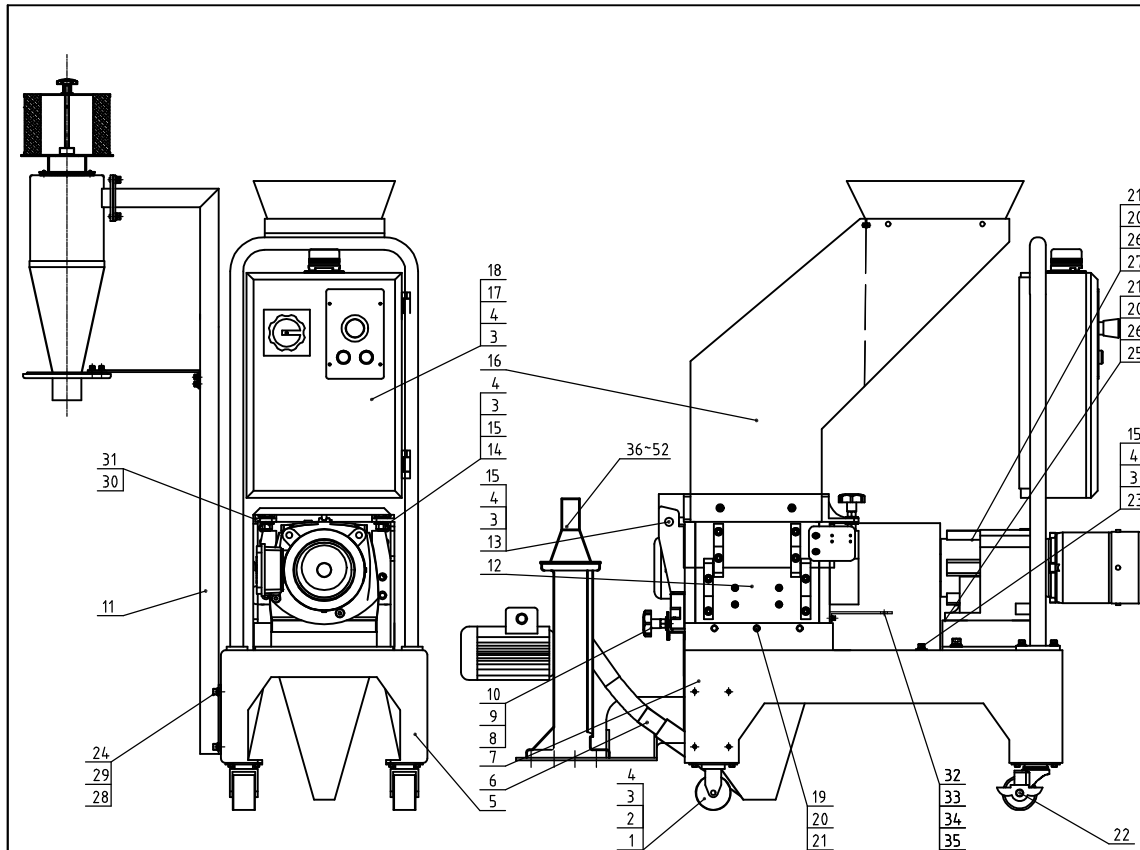

4.8	YW65012000000	Standard spring washer @/1912-Longzine		4	option
4.7	YW60124500000	Hex. bolt @/5781M6-5-8-Longzine		4	option
4.6	YW60081600100	Hex. bolt @/5781M6-5-4-8-Longzine		4	option
4.5	YW66641216000	Flat washer A grade @/19116-Longzine		4	option
4.4	YW65006000100	Standard spring washer @/1916-Longzine		4	option
4.3	YW61062001200	Hex. hex. column head screw @/771M6-2-29-Longzine		4	option
4.2	YW03000300200	Movable caster 3"	Assembly	1	option
4.1	YW02000200000	Stainless steel pipe clamp 2"	SUS201	2	option
4.0	YR60105000200	Steel wire plastic pipe 15" (L=0.3m)		1	option
3.9	BH10162000010	Hinge base pin	Q.235A	1	option
3.8	BL59160000821	Hinge base	Q.235A	1	option
3.7	BM30552300050	Blower 0.55kW	Assembly	1	option
3.6	BL50240200020	Blower fixed plate	Welding parts	1	option
3.5	YW66061300000	Flat washer A grade @/19116.5x2x1.4-Longzine		2	
3.4	YW65006000100	Standard spring washer @/1916-Longzine		2	
3.3	YW61061200000	Hex. hex. column head screw @/771M6-2-29-Longzine		2	
3.2	BL51002401220	Sensor fixed plate	SPCC3.0	1	
3.1	YW68005500000	Hex. hex. flat end lock screw @/771M6-4-Longzine		3	
3.0	BH11241000010	Screw lock nut	4	3	
2.9	YW61082001200	Hex. hex. column head screw @/771M6-2-29-Longzine		4	option
2.8	YW66081900000	Flat washer 8x19x2.0-Longzine		10	option
2.7	YM10572100500	Gear motor SKS72.1-80LH/A	Assembly	1	
2.6	YW61123500000	Hex. hex. column head screw @/771M6-2-29-Longzine		8	
2.5	--	Gear motor mount base	SPH8.0	1	
2.4	YW65008000100	Standard spring washer @/1916-Longzine		10	option
2.3	--	Shaft coupler cover plate	SPCC2.0	1	
2.2	YW03000300900	USA side brake black caster 3"	Assembly	2	
2.1	YW66122400000	Flat washer A grade @/191112.5x2x1.4-Longzine		14	
2.0	YW65012000000	Standard spring washer @/1912-Longzine		14	
1.9	YW61122500000	Hex. hex. column head screw @/771M6-2-29-Longzine		6	
1.8	YW61082001200	Hex. hex. column head screw @/771M6-2-29-Longzine		4	
1.7	--	Control box assembly	Welding parts	1	
1.6	--	Feed case assembly	Assembly	1	
1.5	YW61081600000	Hex. hex. column head screw @/771M6-16-29-Longzine		10	
1.4	BL56002400020	Safety switch fixed plate	SPH8.0	1	
1.3	BH10184900010	Feed bin rotating shaft	Q.235A	2	
1.2	--	Control box assembly	Assembly	1	
1.1	--	Feed case assembly	Assembly	1	option
1.0	YW64012100000	Hex. nut @/16710 M12-Longzine		3	
9	YW66122400000	Flat washer A grade @/191112.5x2x1.4-Longzine		3	
8	BH56240200010	Star assembly	Assembly	3	
7	--	Surge bar	Welding parts	1	
6	--	Suction pipe	SUS201(1.0)	1	
5	--	Base assembly	Welding parts	1	
4	YW66081900000	Flat washer 8x19x2.0-Longzine		30	
3	YW65008000100	Standard spring washer @/1916-Longzine		30	
2	YW60081600100	Hex. Nut @/15781 M6-16-4-8-Longzine		16	
1	YW03000300500	USA flat plate fixed black caster 3"	Assembly	2	

52	YW64000800100	Hex. nut insert hex. nut @/189118		1	option
51	YW64080600000	Hex. nut @/1670 M8-Longzine		1	option
50	YW60082500100	Hex. Nut @/5781M6-5-29-Longzine		1	option
49	YW66122400000	Flat washer A grade @/191112.5x2x1.4-Longzine		8	option

标记	更改前	更改后	更改人	日期	制图	版号	标题	图号	比例	数量	备注
							SG-24.27N				
							齿槽式粉碎机				
							SHINI 信易电热机械股份有限公司 Shini Plastics Technologies, Inc.				
									表面要求		
									物料号		

Weight (kg)	Noise when granulating dB(A)	Max. cutting ability (kg/hr)	Cutting Ability Size (mm)	Small Teeth Cutter Qty	Big Teeth Cutter Qty	Teeth Cutter Qty	Staggered Cutter Qty	Teeth Cutter Mat.	Main Shaft Speed (r.p.m)	Motor Power (KW)	Version No.
240	80-85	6	24.0-270			3	2	SKD11	27	0.75	VER.E

- Note:1)The max.cutting ability depends on the granule's size and property;
 2) The noise during crushing varies according to the granules property and motor;
 3) SKD11 meets the JIS standard No.;
 4) Standard slant teeth cutters, narrow and widened slant teeth cutters are options;
 5) In order to avoid sticking the plastic cutter, all materials to be crushed shall be processed at normal temperature;
 6) Machine Power: 3Ø,400VAC,50Hz;

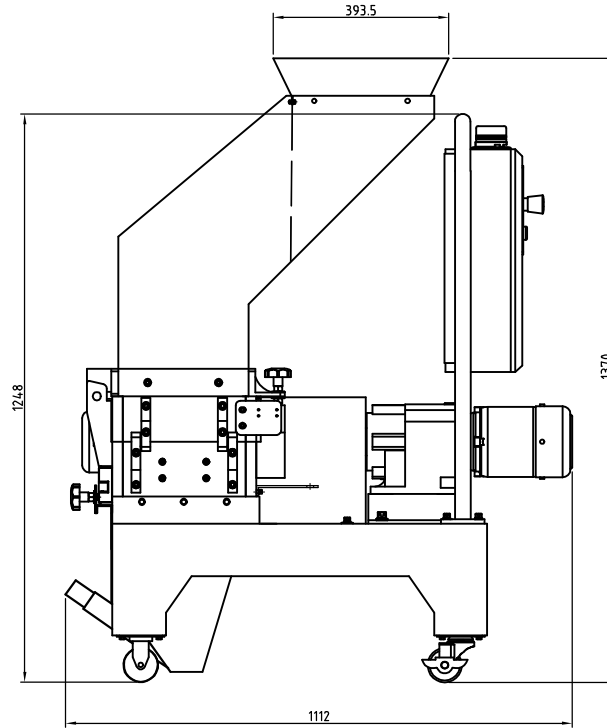
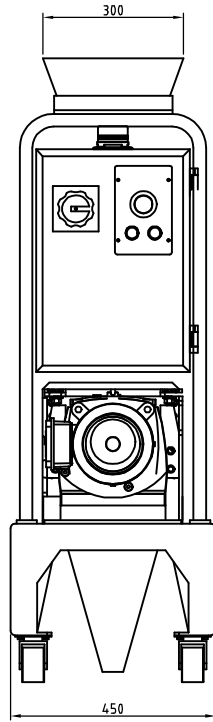

					制图	版号	标题	图号	比例	数量
					设计	核准	SG-24.27N			
					校对		齿槽式粉碎机			材质
					审核		信易电热机械股份有限公司 Shini Plastics Technologies, Inc.		表面要求	
标记	更改前	更改后	更改人	日期				物料号		

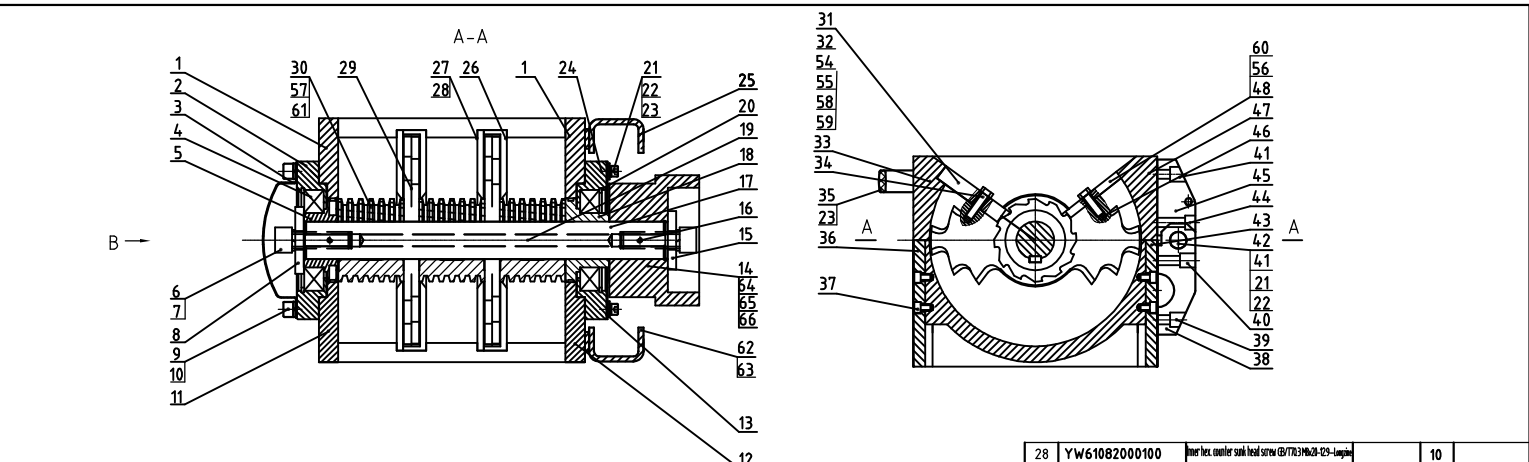

55	YW40240800000	Widened fixed front blade F?	SKD11	1	option	28	YW61082000100	Inner hex. outer sunk head screw GB/T7031M6x20-25-Longzine		10	
54	YW40240700000	Widened fixed front blade F1	SKD11	2	option	27	BH10002400910	Middle plate 2	45	2	
53	YW61122500000	Inner hex. column head screw GB/T7031M6x25-25-Longzine		6		26	BH10002400710	Middle plate 1	45	2	
52	YW61103000100	Inner hex. column head screw GB/T7031M6x30-25-Longzine		20		--		Positioning block 2(left)	Q235A	1	
51	YW69123500000	Spring column pin 12x35	65Mn	12		24	BW30242706610	Right bearing base	QT500-7	1	
50	YW61083500000	Inner hex. column head screw GB/T7031M6x35-25-Longzine		2		23	YW66081900000	Flat washer 8x19x2.0 Longzine		4	
49	BH10242707010	Fixed rear rotating block?	Q235A	2		22	YW65008000100	Standard spring washer GB/T1938-Longzine		8	
48	YW40024000300	Fixed rear blade B	SKD11	3	option	21	YW61081600000	Inner hex. column head screw GB/T7031M6x16-25-Longzine		8	
47	BW30242700610	Upper case front block	QT500-7	1		20	YW69012700000	Elastic collar for hole 120	65Mn	2	
46	YW60103000200	External hex. screw GB/T5283M6x30-25-Longzine		6		19	BH10242706410	Flat key 14x9x4.54	45	1	
45	BH10240900110	Cutting case rotating block 1	Q235A	2		18	BW30002400110	Right bearing sleeve	QT500-7	1	
44	YW61084500000	Inner hex. column head screw GB/T7031M6x45-25-Longzine		2		17	BH10242706110	Main shaft	40Cr	1	
43	BH10242702010	Lower case front block	Q235A	1		16	YW61061001800	Inner hex. column head screw GB/T7031M6x10-42-303US		2	
42	YW66082200100	Large washer C grade GB/T96884x24x2-Longzine	14.0HV	4		15	--	Shaft coupler end washer	Q235A	1	
41	BH10204400010	Cutting chamber rotating shaft	Q235A	2		14	BH10243702540	XL9 shaft coupler (hole dia.: 35mm)	QT500-7	1	
40	YW61084000000	Inner hex. column head screw GB/T7031M6x40-25-Longzine		2		13	BL51244601120	Bearing base cover plate	SPCC1.5	1	
39	YW61082501200	Inner hex. column head screw GB/T7031M6x25-25-Longzine		6		12	BH10242706910	Lower case right end plate	Q235A	1	
38	BH10240900210	Cutting chamber rotating shaft 2	Q235A	2		11	BH10242706810	Lower case left end plate	Q235A	1	
37	YW61081200000	Inner hex. column head screw GB/T7031M6x12-25-Longzine		8		10	YW65012000000	Standard spring washer GB/T19312-Longzine		2	
36	BH10242706210	Lower case front block	Q235A	1		9	YW61220000000	Inner hex. column head screw GB/T7031M6x20-25-Longzine		2	
35	BW20012000140	Handle 12x8	AL	1		8	BL51802100020	Washer	Q235A	1	
34	YW60103500200	Hexagon screw ball GB/T5783M6x35-25-Longzine		6		7	YW65205200000	Standard spring washer GB/T19321		2	
33	BW30242706310	Upper case rear block	QT500-7	1		6	YW61205000000	Inner hex. column head screw GB/T7031M6x20-25-Longzine		2	
32	YW40024000200	Fixed front blade F?	SKD11	1	option	5	BW30024000210	Left bearing sleeve	QT500-7	1	
31	YW40024000100	Fixed front blade F1	SKD11	2	option	4	YW11621300000	Bearing 6213 DDU/VV	GCr1.5	2	
29	BW40240500010	Slaggered blade	SKD11	2		3	BL51002402420	Bearing cover	SPCC1.2	1	
						2	BW30024001010	Left bearing base	QT500-7	1	
						1	BH10242706710	Upper case left & right end plate	Q235A	2	

序号	代号	名称	材料	数量	备注
66	YW68080500000	Inner hex. flat end lock screw GB/T771M6x8-Longzine		2	
65	YW90007500000	XL shaft coupler star washer GR-75		1	
64	BH10243902740	XL9 shaft coupler (hole dia.: 45mm)	QT500-7	1	
63	YW61082001200	Inner hex. column head screw GB/T7031M6x20-25-Longzine		4	
62	--	Positioning block 2 (right)	Q235A	1	
61	YW40241400000	Narrow teeth cutter R	SKD11	3	option
60	BW40131100010	Narrow fixed rear blade B	SKD11	3	option
59	BW40021100010	Narrow fixed front blade F?	SKD11	1	option
58	BW40041100010	Narrow fixed front blade F1	SKD11	2	option
57	YW40241000000	Widened teeth cutter R	SKD11	3	option
56	YW40240900000	Widened fixed rear blade B	SKD11	3	option

制图	版号	标题	图号	比例	数量
设计	核准	SG-2427N		1:1	
校对	审核	粉碎室总成		表面要求	材质
标记	更改前	更改后	更改人	日期	日期
		SHINI 信易电热机械股份有限公司 Shini Plastics Technologies, Inc.		物料号	

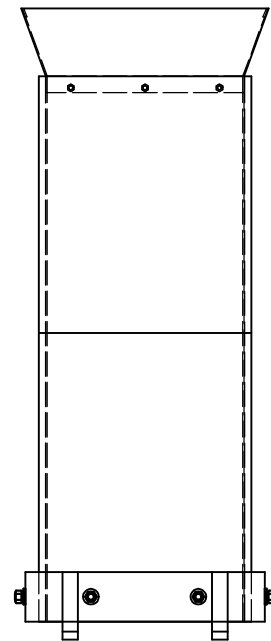
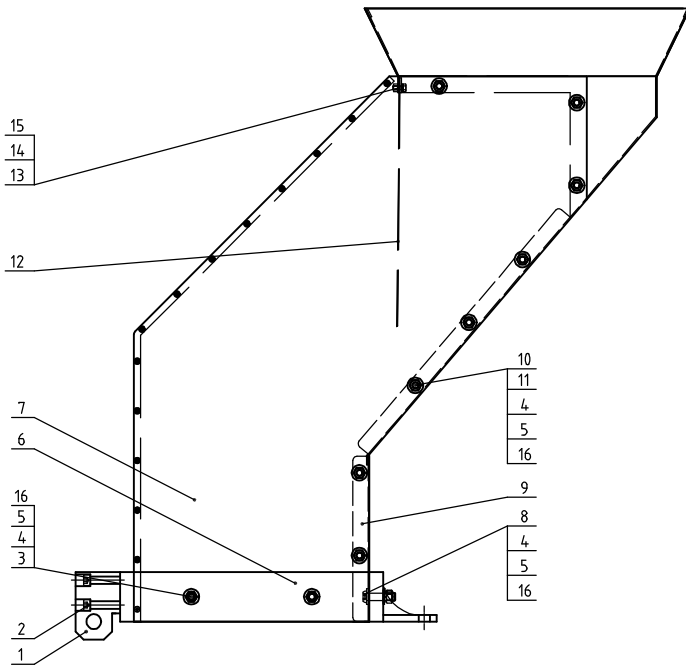

16	YW65008000100	Standard spring washer GB/T93.8-Longine		24	
15	YW6204.1000000	Large recessed flat head screw JS 101/M4X10-Longine		3	
14	YW64.0407000100	Non-metal insert hex. lock nut GB/T889.114	SPCC1.5	3	
13	--	Fender pressing plate	SPCC1.5	1	
12	--	Material fender	white waterproof cloth	1	
11	YW61082500200	Insert hex flat head screw GB/T914.5-8.9-Longine		16	
10	--	Feed part	SPCC1.5	1	
9	--	Feed box rear lower plate	SECC2.0	1	
8	YW61083500100	Insert hex flat head screw GB/T914.5-8.9-Longine		2	
7	BR9024.1700110	Feed box	Assembly	1	
6	--	Feed box lower base	Assembly	1	
5	YW64.000800100	Non-metal insert hex. lock nut GB/T889.114		24	
4	YW66081900000	Flat washer 8x19x2.0 Longine		32	
3	YW61084.000100	Insert hex flat head screw GB/T914.5-8.9-Longine		6	
2	YW61085.000000	Insert hex round head screw GB/T914.6-8.9-Longine		4	
1	BH1024.1300110	Feed box rotating block 1	Q235A	2	
序号	代 号	名 称	材 料	数 量	备 注

					制图	版号	标题	图号	比例	数量	
					设计	核	进料箱总成		1:1	1	材质
					校对	准			表面要求		
标记	更改前	更改后	更改人	日期	审核	日期	信易电热机械股份有限公司 Shini Plastics Technologies, Inc.		物料号		

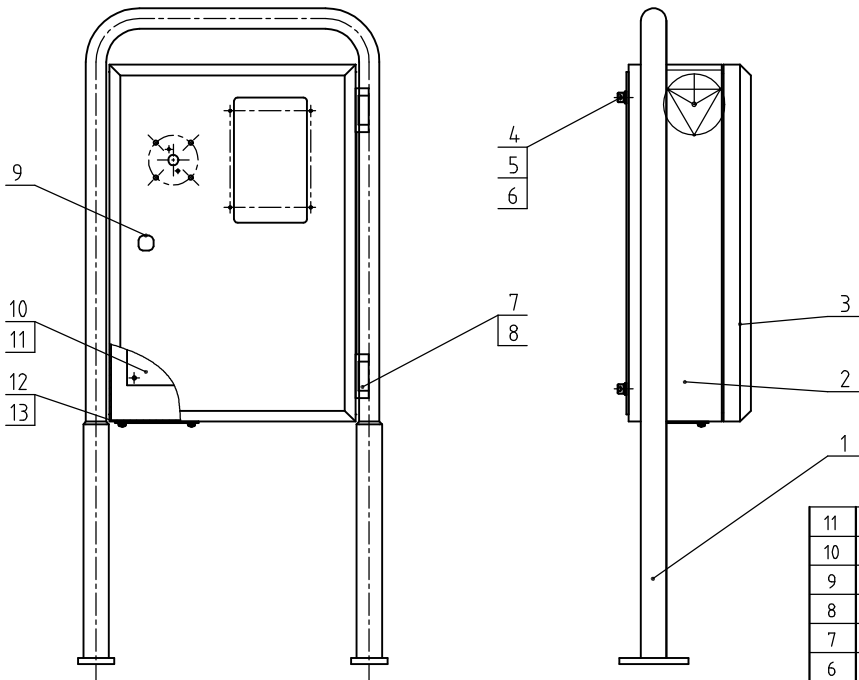

11	YW64000500000	Non-metal insert hex lock nut GB/T889.1M5		4	
10	--	Electrical fixed plate	SECC1.5	1	
9	YW00816100000	Door lock (MS316-1 black with key)	Alum. alloy	1	
8	YW63050800000	Cross recessed pan head screws GB/T-818 M5x8-Longzine		8	
7	YW06219100000	Large hinge CL219-1	Alum. alloy	2	
6	YW66081900000	Flat washer 8x19x2.0 Longzine		4	
5	YW65008000100	Standard spring washer GB/T93 8-Longzine		4	
4	YW61082001200	Inner hex. column head screw GB/T70.1M5x20-12.9-Longzine		4	
3	--	Door plank	SPCC2.0	1	
2	--	Control box body	SPCC2.0	1	
1	--	Control box mount rack	Welding parts	1	
序号	代号	名称	材料	数量	备注

13	YW62050500000	Large recessed flat head screw JIS 1111 M5X5-Longzine		4	
12	BL50135000020	Wire clamp fixed plate PG65	SPCC2.0	1	

				制图	版号	标题	SG-24N	图号	比例	数量
				设计	核准	控制箱总成			材质	
				校对		信易電熱機械股份有限公司 Shini Plastics Technologies, Inc.		表面要求		
标记	更改前	更改后	更改人	日期	审核			日期	物料号	

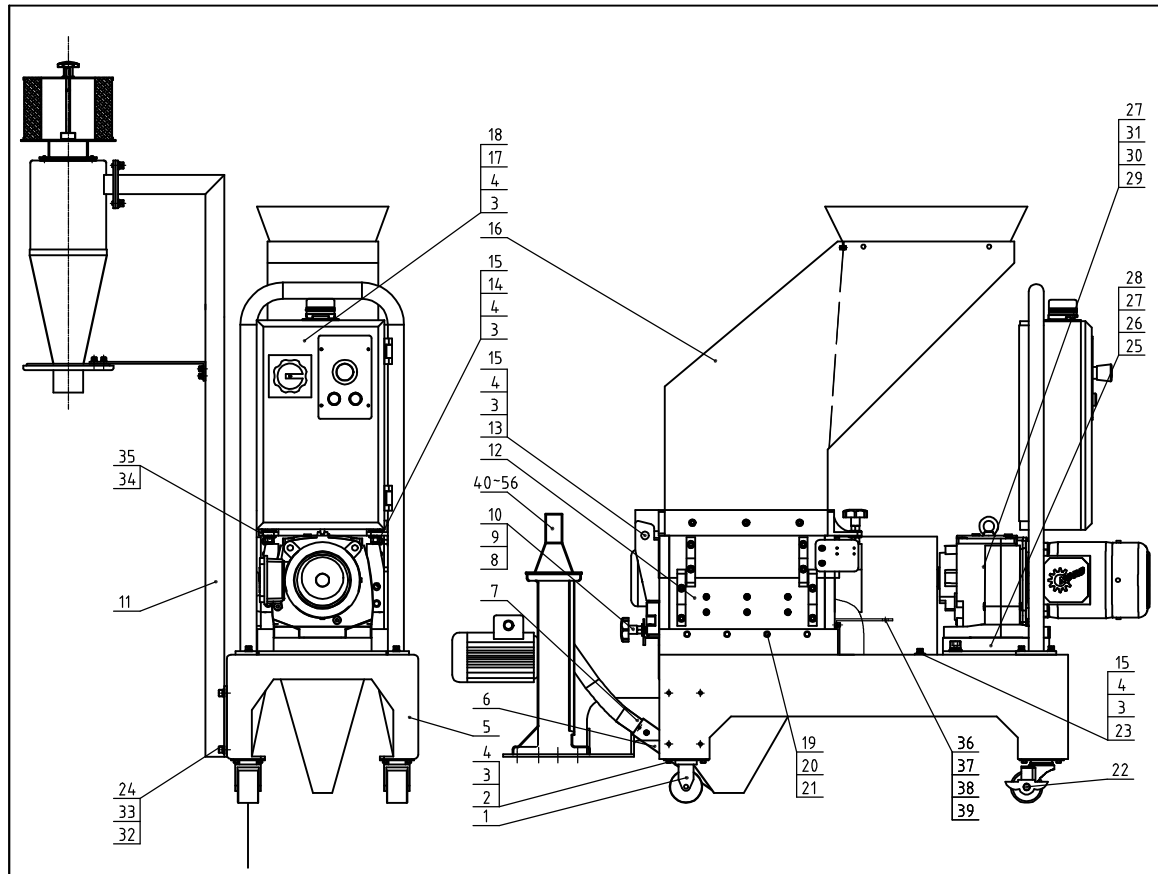

48	YW65006000100	Standard spring washer GB/T191-Longzine		4	option
47	YW61062001200	Inner hex column head screw GB/T7111M6x29-Longzine		4	option
46	YW03000300200	Movable caster 3"	Assembly	1	option
45	YW02000200000	Stainless steel pipe clamp 2"	SUS201	2	option
44	YR60105000200	Steel wire plastic pipe 15" (L=0.3m)		1	option
43	BH10162000010	Hinge base pin	Q235A	1	option
42	BL59160000821	Hinge base	Q235A	1	option
41	BM30552300050	Blower 0.55kW	Assembly	1	option
40	BL50240200020	Blower fixed plate	Welding parts	1	option
39	YW66061300000	Flat washer A grade GB/T911 016x12x14-Longzine		2	
38	YW65006000100	Standard spring washer GB/T918-Longzine		2	
37	YW61061200000	Inner hex column head screw GB/T7111M6x29-Longzine		2	
36	BL51002401220	Sensor fixed plate	SPCC3.0	1	
35	YW68005500000	Inner hex flat end lock screw GB/T7714B-Longzine		3	
34	BH11241000010	Screw lock nut		4	3
33	YW61082001200	Inner hex column head screw GB/T7111M6x29-Longzine		4	option
32	YW66081900000	Flat washer 8x19x2.0-Longzine		10	option
31	YW09173000000	Flat washer 17x30x3-Longzine		4	
30	YW61166000000	Inner hex column head screw GB/T7111M6x29-Longzine		4	
29	YM10773100000	Gear motor SK773.1-90LH/4	Assembly	1	
28	YW66164000000	Waler 16x16x5-Longzine (non-standard)		4	
27	YW65016200000	Standard spring washer GB/T918-Longzine		8	
26	YW61165000000	Inner hex column head screw GB/T7111M6x29-Longzine		4	
25	--	Gear motor mount base	SPH8.0	1	
24	YW65008000100	Standard spring washer GB/T918-Longzine		10	option
23	--	Shaft coupler cover plate	SPCC1.5	1	
22	YW03000300900	USA Flat plate fixed black caster 3"	Assembly	2	
21	YW66122400000	Flat washer A grade GB/T911 016x12x14-Longzine		8	
20	YW65012000000	Standard spring washer GB/T918-Longzine		8	
19	YW61122500000	Inner hex column head screw GB/T7111M6x29-Longzine		8	
18	YW61082001200	Inner hex column head screw GB/T7111M6x29-Longzine		4	
17	--	Control box assembly	Welding parts	1	
16	--	Feed case assembly	Assembly	1	
15	YW61081600000	Inner hex column head screw GB/T7111M6x29-Longzine		10	
14	BL56002400020	Safety switch fixed plate	SPH8.0	1	
13	BH10184900010	Feed box rotating shaft	Q235A	2	
12	--	Cutting chamber assembly	Assembly	1	
11	--	Cyclone assembly	Assembly	1	option
10	YW64012100000	Hex nut GB/T6170 M12-Longzine		3	
9	YW66122400000	Flat washer A grade GB/T911 016x12x14-Longzine		3	
8	BH56240200010	Star assembly	Assembly	3	
7	--	Section pipe	SUS201(1.0)	1	
6	--	Storage bin	Welding parts	1	
5	--	Base assembly	Welding parts	1	
4	YW66081900000	Flat washer 8x19x2.0-Longzine		30	
3	YW65008000200	Standard spring washer GB/T918-Longzine		30	
2	YW60081600100	Hex bolt GB/T5781 M6x16-4.8-Longzine		16	
1	YW03000300500	USA Flat plate fixed black caster 3"	Assembly	2	

56	YW64000800100	Hex metal insert hex lock nut GB/T8919B		1	option
55	YW64080600000	Hex nut GB/T6170 M8-Longzine		1	option
54	YW60082500100	Hex bolt GB/T5781 M8x25-Longzine		1	option
53	YW66122400000	Flat washer A grade GB/T911 016x12x14-Longzine		8	option
52	YW65012000000	Standard spring washer GB/T918-Longzine		4	option
51	YW60124500000	Hex bolt GB/T5781 M6x45-4.8-Longzine		4	option
50	YW60081600100	Hex bolt GB/T5781 M6x16-4.8-Longzine		4	option
49	YW66641216000	Flat washer A grade GB/T911 6-Longzine		4	option

					制图	版号	标题	SG-24.36N	图号	比例	数量
					设计	核准	齿槽式粉碎机			表面要求	物料号
					校对		SHINI 信昌电热机械股份有限公司				
标记	更改前	更改后	更改人	日期	审核	日期	Shini Plastics Technologies, Inc.				

Weight (kg)	Noise when granulating dB(A)	Max. cutting ability (kg/hr)	Cutting Ability Size (mm)	Small Teeth Cutter Qty.	Big Teeth Cutter Qty.	Teeth Cutter Qty.	Staggered Cutter Qty.	Teeth Cutter Mat.	Main Shaft Speed (r.p.m)	Motor Power (KW)	Version No.
257	80-85	8.5	24.0×365			4	3	SKD11	27	1.5	VER.E

- Note:1) The max. cutting ability depends on the granule's size and property;
 2) The noise during crushing varies according to the granules property and motor;
 3) SKD11 meets the JIS standard No.;
 4) Standard slant teeth cutters, narrow and widened slant teeth cutters are options;
 5) In order to avoid sticking the plastic cutter, all materials to be crushed shall be processed at normal temperature;
 6) Machine Power: 3Ø, 400VAC, 50Hz;

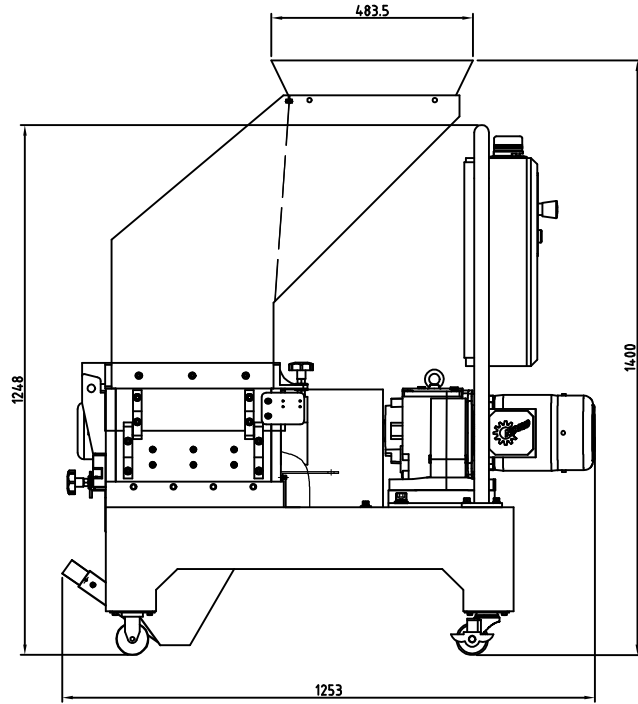
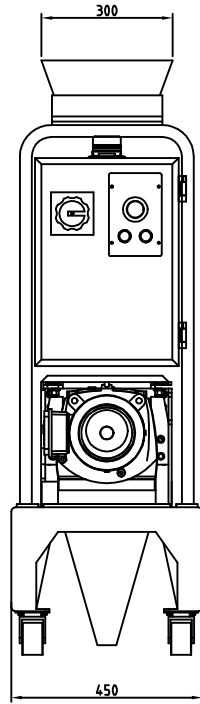

					制图	版号	标题	图号	比例	数量
					设计	核	SG-2436N		1:1	材质
					校对	准	齿槽式粉碎机			
					审核	日期	 信易電熱機械股份有限公司 Shini Plastics Technologies, Inc.		表面要求	
标记	更改前	更改后	更改人	日期	审核	日期			物料号	

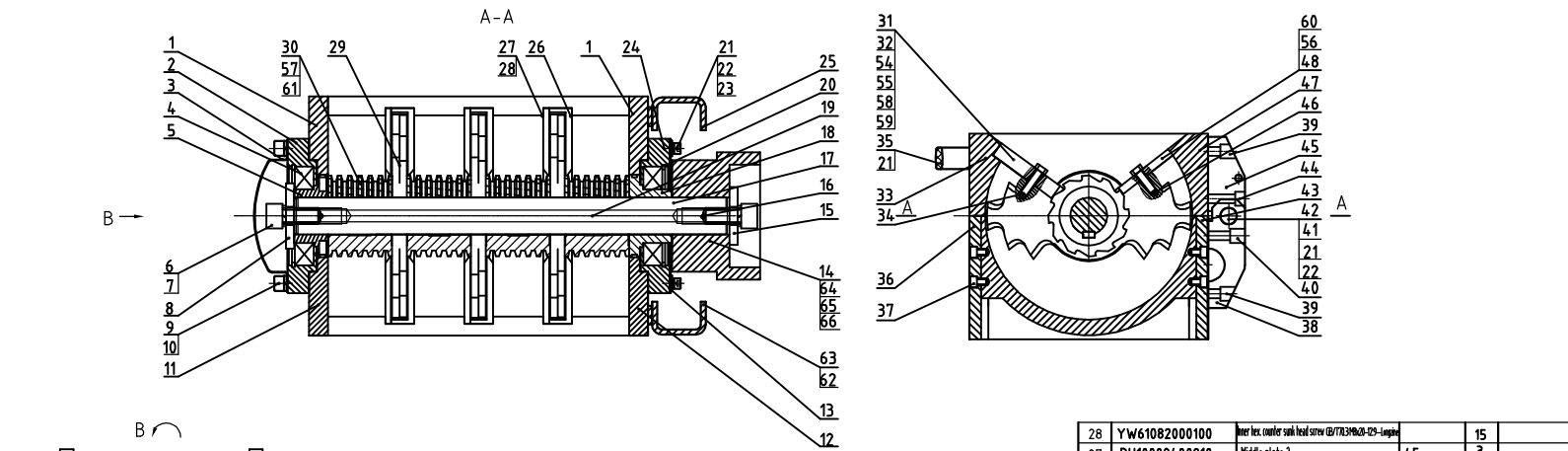

66	YW68080500000	Inner hex flat end lock screw GB/T711M16x4-Longzine		2		39	YW61082501200	Inner hex column head screw GB/T711M16x5-L29-Longzine		6	10	YW65012000000	Standard spring washer GB/193-Longzine		2	
65	YW90007500000	XL shaft coupler star washer GR-75		1		38	BH10240900210	Cutting chamber rotating shaft 2	Q235A	2	9	YW61122000000	Inner hex column head screw GB/T711M16x3-L29-Longzine		2	
64	BH10243902740	XL9 shaft coupler (hole dia: 45mm)	QT500-7	1		37	YW61081200000	Inner hex column head screw GB/T711M16x2-L29-Longzine		12	8	BL51802100020	Washer	Q235A	1	
63	YW61082001200	Inner hex column head screw GB/T711M16x3-L29-Longzine		4		36	BH10243603610	Lower case front block	Q235A	1	7	YW65205200000	Standard spring washer GB/193-L		2	
62	--	Positioning block 2(right)	Q235A	1		35	BW20012000140	Handle 120x8	AL	1	6	YW61205000000	Inner hex column head screw GB/T711M16x3-L29-Longzine		2	
61	YW40241400000	Narrow teeth cutter R	SKD11	4	option	34	YW60103500200	Pepper screw GB/15183M16x5-L29-Longzine		8	5	BW30024000210	Left bearing sleeve	QT500-7	1	
60	BW40131100010	Narrow fixed rear blade B	SKD11	4	option	33	BW30243603410	Upper case rear block	QT500-7	1	4	YW11621300000	Bearing 6213 DDU/VV	GCr15	2	
59	BW40021100010	Narrow fixed front blade F2	SKD11	2	option	32	YW40024000200	Fixed front blade F2	SKD11	2	standard	3	BL51002402420	Bearing cover	SPCC1.2	1
58	BW40041100010	Narrow fixed front blade F1	SKD11	2	option	31	YW40024000100	Fixed front blade F1	SKD11	2	standard	2	BW30024001010	Left bearing base	QT500-7	1
57	YW40241000000	Widened teeth cutter R	SKD11	4	option	30	YW40024000400	Teeth cutter R	SKD11	4	standard	1	BH10242706710	Upper case left & right end plate	Q235A	2
56	YW40240900000	Widened fixed rear blade B	SKD11	4	option	29	BW40240500010	Slagger blade	SKD11	3						

标题	SG-24.36N	图号	比例	数量	备注
设计			1:1		
校核					
审核					
日期					
版号					
核准					
日期					
物料号	SHINI 信昌电热机械股份有限公司 Shini Plastics Technology, Inc.		表面要求		

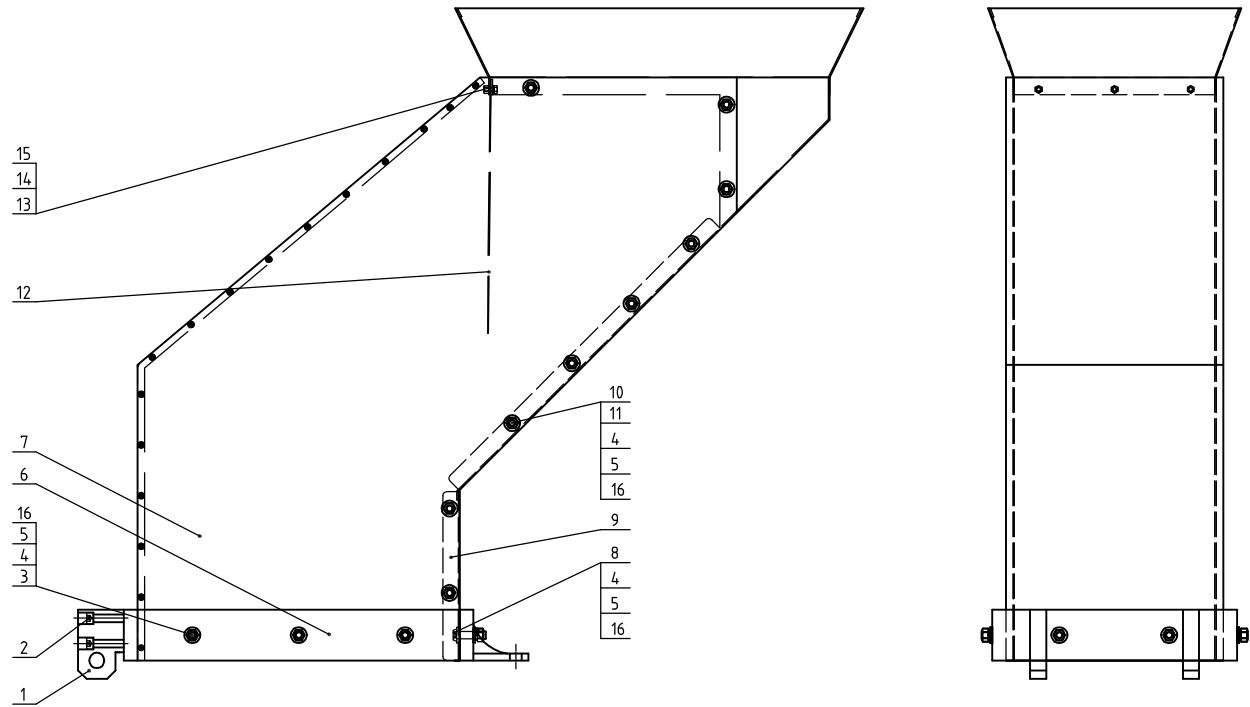

16	YW65008000100	Standard spring washer @7/16x5/8-Longzine		28	8	YW61083500100	Inter hex flat head screw @7/16x5/8-24-Longzine		2
15	YW62041000000	Large recessed flat head screw JS1011M X10-Longzine		3	7	BR90243600210	Feed box	Assembly	1
14	YW64040700100	Non-metal insert hex lock nut @B/T08911M		3	6	--	Feed box lower base	Assembly	1
13	--	Fender pressing plate	SPCC1.5	1	5	YW64000800100	Non-metal insert hex lock nut @B/T08911M		28
12	--	Material fender	white ultrahigh dath	1	4	YW66081900000	Flat washer 8x19x2.0 Longzine		38
11	YW61082500200	Inter hex flat head screw @7/16x5/8-24-Longzine		18	3	YW61084000100	Inter hex flat head screw @7/16x5/8-24-Longzine		8
10	--	Feed part	SPCC1.5	1	2	YW61085000000	Inter hex round head screw @7/16x5/8-24-Longzine		4
9	--	Feed box rear lower plate	SECC2.0	1	1	BH10241300110	Feed box relining block I	Q235A	2

制图	版号	标题	图号	比例	数量
设计	核准	SG-2436N			
校对		进料箱总成		表面要求	材质
标记	更改前	更改后	更改人	日期	审核
				SHINI 信易电热机械股份有限公司 Shini Plastics Technologies, Inc.	
				物料号	

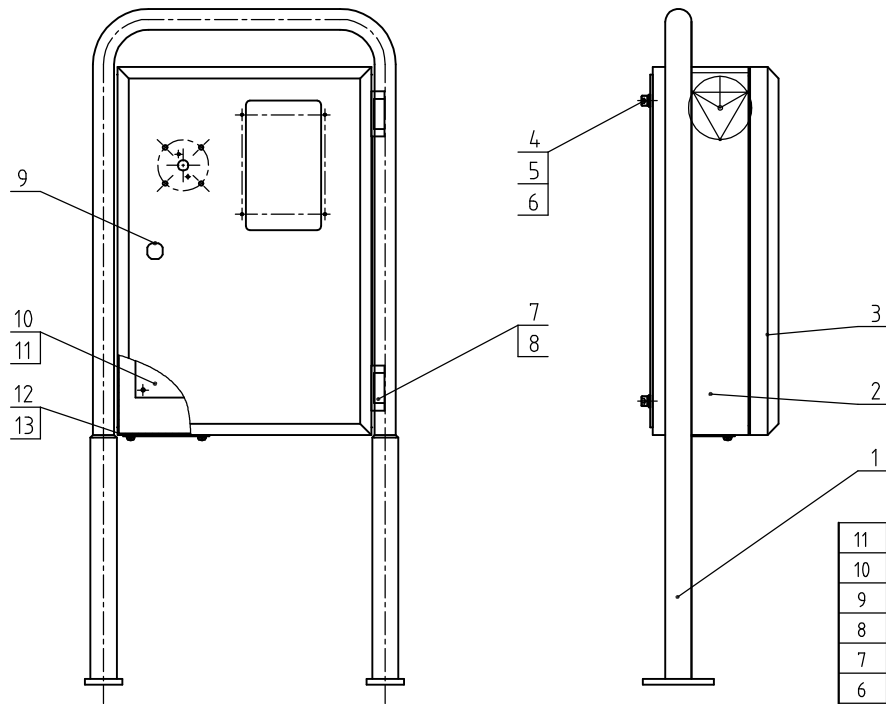

11	YW64.000500000	Non-metal insert hex. lock nut GB/T889.1 M6		4	
10	--	Electrical fixed plate	SECC1.5	1	
9	YW00816100000	Door lock (MS816-1 black with key)	Alum. alloy	1	
8	YW63050800000	Cross recessed pan head screws GB/T-818 M6x8-Longzine		8	
7	YW06219100000	Large hinge CL219-1	Alum. alloy	2	
6	YW66081900000	Flat washer 8x19x2.0 Longzine		4	
5	YW65008000100	Standard spring washer GB/T93 8-Longzine		4	
4	YW61082001200	Inner hex. column head screw GB/T770.1 M6x20-12.9-Longzine		4	
3	--	Door plank	SPCC2.0	1	
2	--	Control box body	SPCC2.0	1	
1	--	Control box mount rack	Welding parts	1	
	序号	代号	名称	材料	数量 备注

13	YW62050500000	Large recessed flat head screw JIS 1111 M5X5-Longzine		4	
12	BL50135000020	Wire clamp fixed plate PG335	SPCC2.0	1	

					制图	版号	标题	图号	比例	数量
					设计	核准	控制箱总成		表面要求	材质
					校对		信易电热机械股份有限公司 Shini Plastics Technologies, Inc.		表面要求	
标记	更改前	更改后	更改人	日期	审核	日期		物料号		

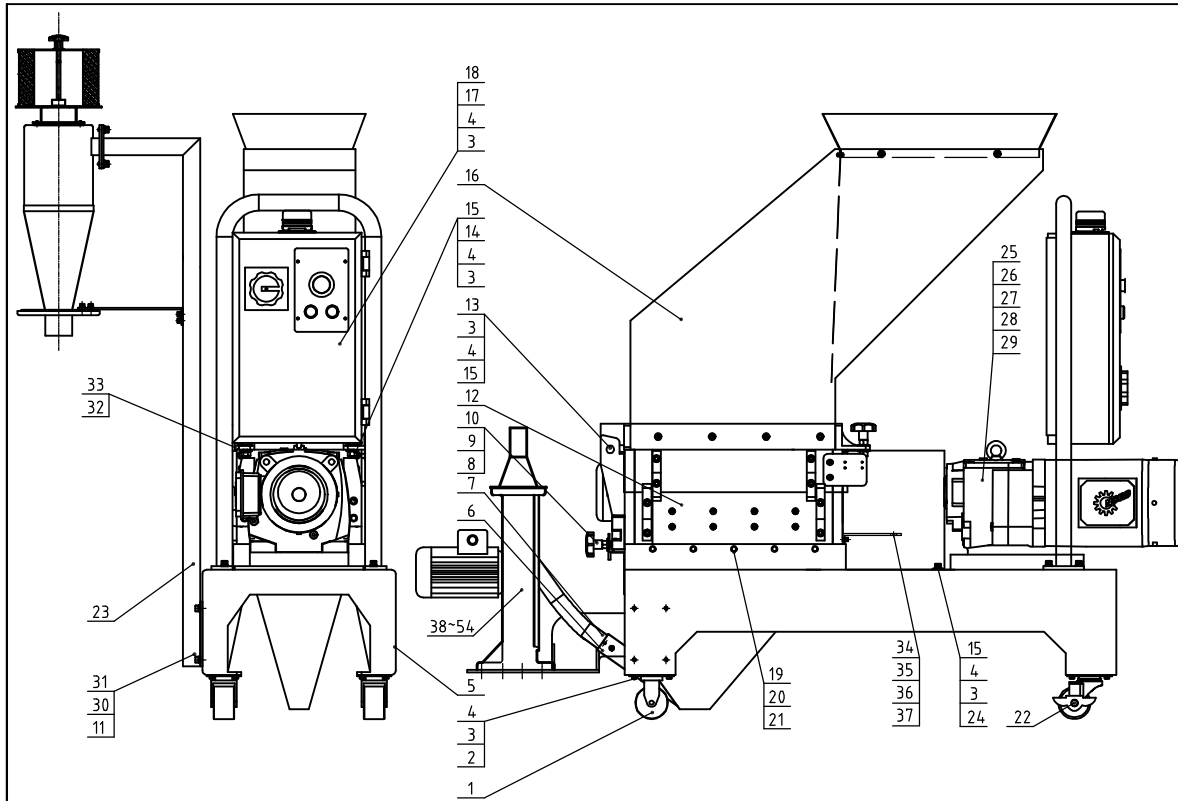

47	YW66641216000	Flat washer A grade GB/T191.1-Longzine		4	option
46	YW65006000100	Standard spring washer GB/T191-Longzine		4	option
45	YW61062001200	Hex hex column head screw GB/T70.1Hex2-Longzine		4	option
44	YW03000300200	Movable caster 3"	Assembly	1	option
43	YW02000200000	Stainless steel pipe clamp 2"	SUS201	2	option
42	YR60105000200	Steel wire plastic pipe 15" (L=0.3m)		1	option
41	BH10162000010	Hinge base pin	Q235A	1	option
40	BL59160000821	Hinge base	Q235A	1	option
39	BM30552300050	Blower 0.55kw	Assembly	1	option
38	BL50240200020	Blower fixed plate	Welding parts	1	option
37	YW66061300000	Flat washer A grade GB/T191.1Hex1.6x1.6-Longzine		2	
36	YW65006000100	Standard spring washer GB/T191-Longzine		2	
35	YW61061200000	Hex hex column head screw GB/T70.1Hex2-Longzine		2	
34	BL51002401220	Sensor fixed plate	SPCC3.0	1	
33	YW68005500000	Hex hex flat head lock screw GB/T77.1Hex5-Longzine		3	
32	BH11241000010	Screw lock nut	4	3	
31	YW66081900000	Flat washer 8x19x2.0-Longzine		10	option
30	YW65008000100	Standard spring washer GB/T191-Longzine		10	option
29	--	Motor adjusting plate		2	
28	YW66163000000	Flat washer A grade GB/T191.1Hex1.6x1.6-Longzine		4	
27	YW61167000000	Hex hex column head screw GB/T70.1Hex1.6x1.6-Longzine		4	
26	YM10873100000	Gear motor SP031-MXL1/4-2.2kW 1-5.5	Assembly	1	
25	YW65016200000	Standard spring washer GB/T191-Longzine		4	
24	--	Shaft coupler cover plate	SPCC1.5	1	
23	--	Cyclone assembly	Assembly	1	option
22	YW03000300900	USA flat plate fixed black caster 3"	Assembly	2	
21	YW66122400000	Flat washer A grade GB/T191.1Hex2x2-Longzine		10	
20	YW65012000000	Standard spring washer GB/T191-Longzine		10	
19	YW61122500000	Hex hex column head screw GB/T70.1Hex2.5-Longzine		10	
18	YW61082001200	Hex hex column head screw GB/T70.1Hex2-Longzine		4	
17	--	Control assembly	Welding parts	1	
16	--	Feed case assembly	Assembly	1	
15	YW61081600000	Hex hex column head screw GB/T70.1Hex1.6-Longzine		10	
14	BL56002400020	Safety catch fixed plate	SPH8.0	1	
13	BH10184900010	Feed bin rotating shaft	Q235A	2	
12	--	Feeding chamber assembly	Assembly	1	
11	YW61082001200	Hex hex column head screw GB/T70.1Hex2-Longzine		4	option
10	YW64012100000	Hex nut GB/T6170 M12-Longzine		3	
9	YW66122400000	Flat washer A grade GB/T191.1Hex2x2-Longzine		3	
8	BH56240200010	Sieve assembly	Assembly	3	
7	--	Section pipe	SUS201(1.0)	1	
6	--	Storage bin	Welding parts	1	
5	--	Base assembly	Welding parts	1	
4	YW66081900000	Flat washer 8x19x2.0-Longzine		30	
3	YW65008000200	Standard spring washer GB/T191-Longzine		30	
2	YW60081600100	Hex nut GB/T5781 M8x1.6-L8-Longzine		16	
1	YW03000300500	USA flat plate fixed black caster 3"	Assembly	2	

54	YW64000800100	Hex-head insert hex lock nut GB/T881.1#8		1	option
53	YW64080600000	Hex nut GB/T6170#8-Longzine		1	option
52	YW60082500100	Hex bolt GB/T5781Hex2.5-L8-Longzine		1	option
51	YW66122400000	Flat washer A grade GB/T191.1Hex2x2-Longzine		8	option
50	YW65012000000	Standard spring washer GB/T191-Longzine		4	option
49	YW60124500000	Hex bolt GB/T5781Hex4.8-L8-Longzine		4	option
48	YW60081600100	Hex bolt GB/T5781Hex1.6-L8-Longzine		4	option

制图	版号	标题	SG-244.6N	图号	比例	数量
设计	核准	齿啮式粉碎机			1:1	1
校对	日期				表面要求	
审核	日期				物料号	
标记	更改前	更改后	更改人	日期	SHINI 信昂电热机械股份有限公司 Shini Plastics Technologies, Inc.	

Weight (kg)	Noise when granulating dB(A)	Max. cutting ability (kg/hr)	Cutting Ability Size (mm)	Small Teeth Cutter Qty.	Big Teeth Cutter Qty.	Teeth Cutter Qty.	Slaggered Cutter Qty.	Teeth Cutter Mat.	Main Shaft Speed (r.p.m)	Motor Power (KW)	Version No.
330	80~85	11	24.0×4.60			5	4	SKD11	27	2.2	VER.E

- Note:1) The max. cutting ability depends on the granule's size and property;
 2) The noise during crushing varies according to the granules property and motor;
 3) SKD11 meets the JIS standard No.;
 4) Standard slant teeth cutters, narrow and widened slant teeth cutters are options;
 5) In order to avoid sticking the plastic cutter, all materials to be crushed shall be processed at normal temperature;
 6) Machine Power: 3Ø, 400VAC, 50Hz;

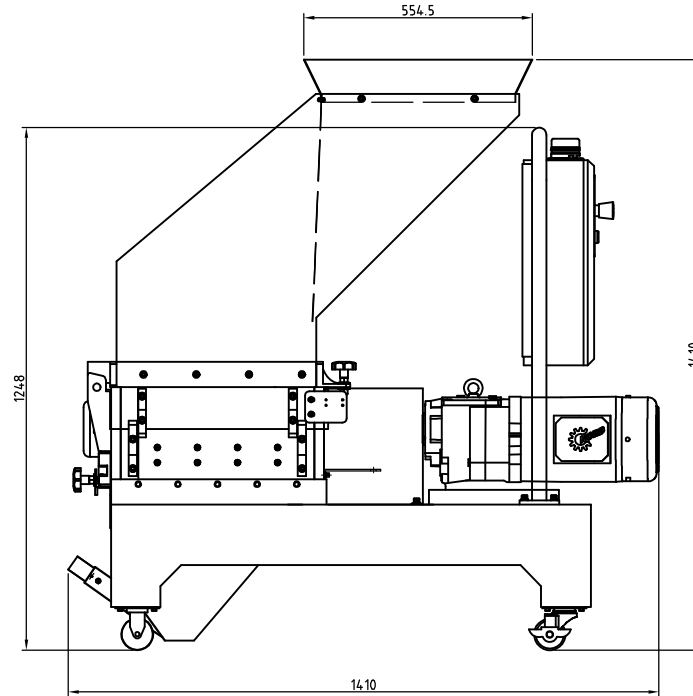
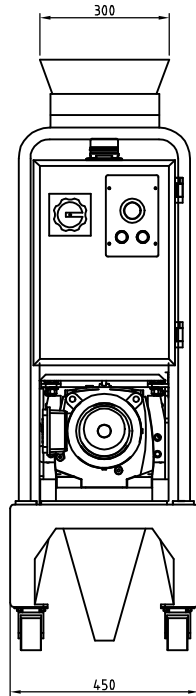

					制图	版号	标题	SG-2446N	图号	比例	数量
					设计	核准	齿槽式粉碎机			表面要求	材质
					校对		 信昂電熱機械股份有限公司 Shini Plastics Technologies, Inc.				
标记	更改前	更改后	更改人	日期	审核	日期			物料号		

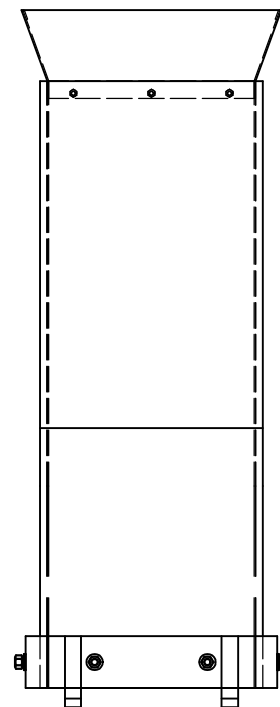
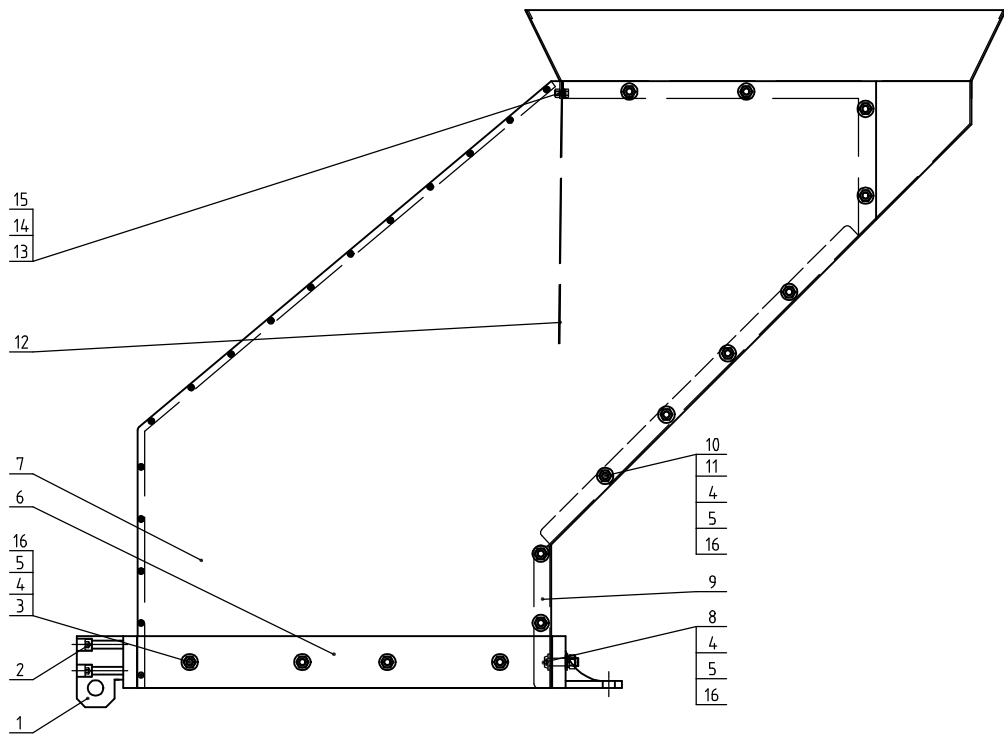

16	YW65008000100	Standard spring washer GB/T93 8-Longzine		32	8	YW61083500100	hex hex flat head head screw GB/T21706.5-25-Longzine		2
15	YW62041000000	Large recessed flat head screw JS 111/MX10-Longzine		3	7	BR9024.4600110	Feed box	Assembly	1
14	YW64040700100	Non-metal insert hex lock nut GB/T889.114		3	6	--	Feed box lower base	Assembly	1
13	--	Fender pressing plate	SPCC1.5	1	5	YW64000800100	Non-metal insert hex lock nut GB/T889.114		32
12	--	Material fender	white safety proof cloth	1	4	YW66081900000	Flat washer 8x19x2.0 Longzine		4.4
11	YW61082500200	hex hex flat head head screw GB/T21706.5-25-Longzine		20	3	YW61084000100	hex hex flat head head screw GB/T21706.5-25-Longzine		10
10	--	Feed port	SPCC1.5	1	2	YW61085000000	hex hex round head head screw GB/T21706.5-25-Longzine		4
9	--	Feed box rear lower plate	SECC2.0	1	1	BH1024.1300110	Feed box rotating block 1	Q235A	2

制图	版号	标题	SG-2446N	图号	比例	数量
设计	核准	进料箱总成			表面要求	材质
校对		信易电热机械股份有限公司 Shini Plastics Technologies, Inc.		物料号		
标记	更改前	更改后	更改人	日期	审核	日期

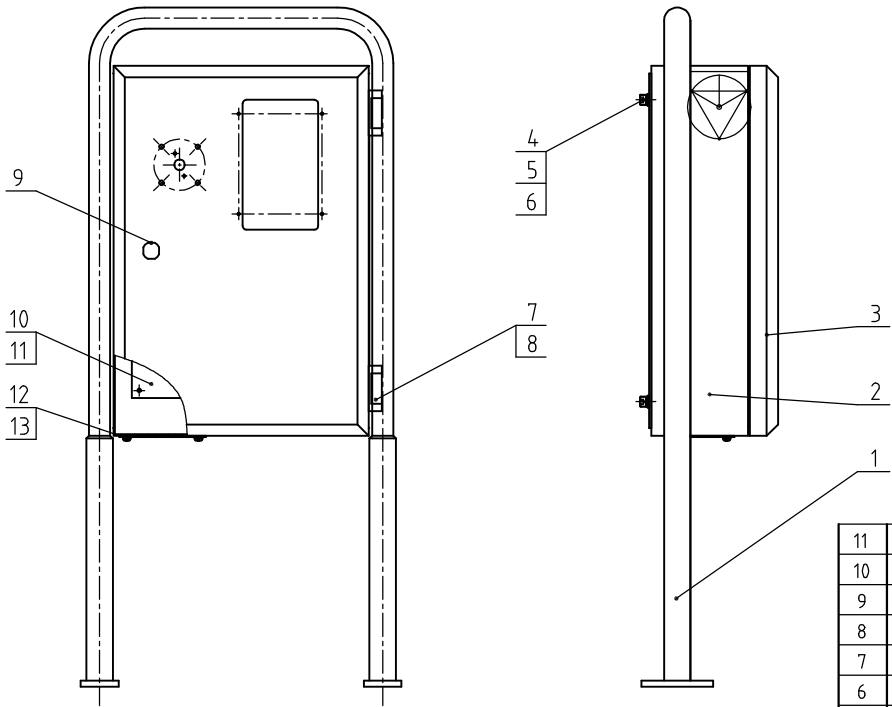

11	YW64000500000	Non-metal insert hex. lock nut GB/T889.1M5		4	
10	--	Electrical fixed plate	SECC1.5	1	
9	YW00816100000	Door lock (MS816-1 black with key)	Alum. alloy	1	
8	YW63050800000	Cross recessed pan head screws GB/T-818M5x8-Longzine		8	
7	YW06219100000	Large hinge Q235-1	Alum. alloy	2	
6	YW66081900000	Flat washer 8x19x2.0 Longzine		4	
5	YW65008000100	Standard spring washer GB/T93 8-Longzine		4	
4	YW61082001200	Inner hex. column head screw GB/T70.1M8x20-12.9-Longzine		4	
3	--	Door plank	SPCC2.0	1	
2	--	Control box body	SPCC2.0	1	
1	--	Control box mount rack	Welding parts	1	
13	YW62050500000	Large recessed flat head screw JS 1111M5X5-Longzine		4	
12	BL50135000020	Wire clamp fixed plate P6135	SPCC2.0	1	
序号	代号	名称	材料	数量	备注

制图	版号	标题	SG-24N	图号	比例	数量
设计	核准	控制箱总成			表面要求	材质
校对	核准					
标记	更改前	更改后	更改人	日期	审核	日期
				信易电热机械股份有限公司 Shini Plastics Technologies, Inc.		物料号