

Accessories

ACF

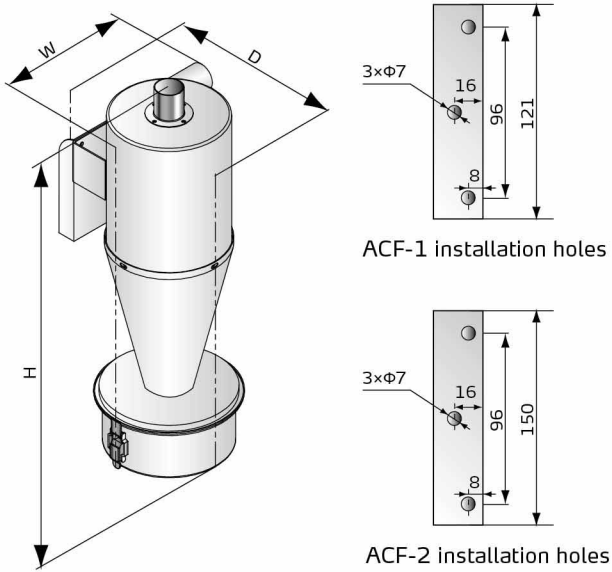

Features

- ACF filter with SAL-G hopper loader in the dusty application.
- It is mounted on vacuum line of the main vacuum unit.
- It features a detachable dust collection bin and reduces the maintenance cycle.

Model	Capacity (H×W×D)		Pipe diameter (inch)
	mm	inch	
ACF-1	mm	550×220×235	1.5
	inch	21.7×8.7×9.3	
ACF-2	mm	550×220×235	2.0
	inch	21.7×8.7×9.3	

MST-S

100, 200, 300 and 500kgs material storage tank for SSC screw feeding application.



Model	MST-	100S	200S	300S	500S
H	mm	1287	1387	1637	1726
	inch	46.5	50.8	60.6	64.2
W	mm	621	821	943	1243
	inch	24.2	32	36.6	48.8
D	mm	625	825	947	1247
	inch	24.2	32	36.6	48.8
Weight	kg	52	66	80	110
	lb	115	146	176	243



SVH/SMH Series

■ Coding Principle

SVH/SMH-xL - xxx

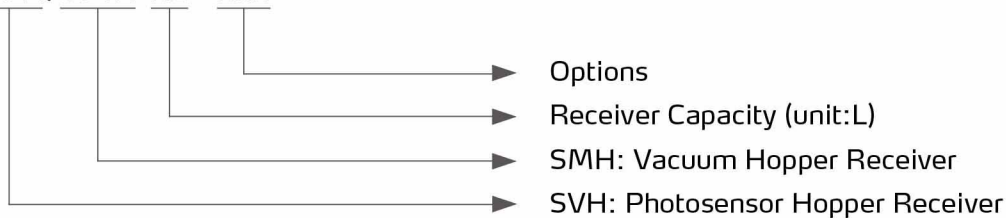

■ Features

- This series of hopper receiver can work with most of the main vacuum units, such as SAL-G and SAL-UG series.
- SMH receiver is suitable for mounting on the dryer, storage tank, or machine hopper.
- SVH receiver is designed to be mounted directly on feeding throat of the plastic processing machine. It required no machine hopper and kept very little dried material before the process.
- Stainless steel hopper receiver
- Standard equipped with steel wired mesh filter screen

■ Accessory & Options

- SMH-6L/12L can work with storage collective hopper SCH-6L in the direct feeding throat mounting application.
- Optional enhanced mixing technology for proportional valve SPV-U application. Add "QM" at the end of the model code.

SVH/SMH Series

Outline Drawings

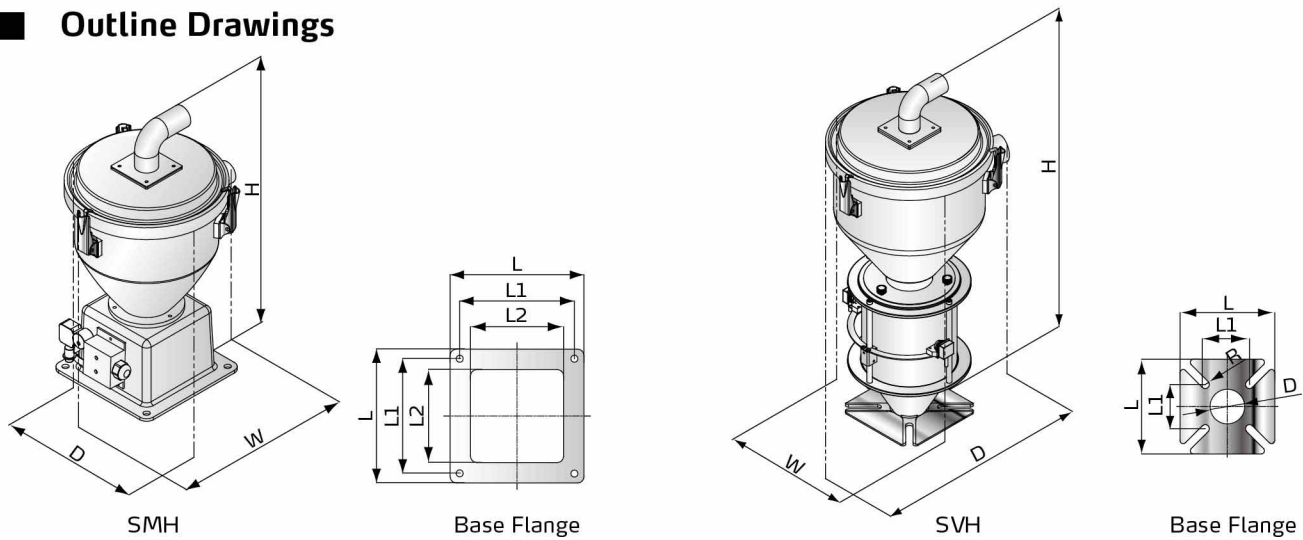

SVH Specifications

Model	Receiver			Conveying pipe dia. (inch)	Vacuum pipe dia. (inch)
	Capacity (L)	Dimension H×W×D (mm)	Weight (kg)		
SVH-3L	3	460×260×315	3	1.5	1.5
SVH-6L	6	600×260×305	7	1.5	1.5
SVH-12L	12	700×300×365	11	1.5	1.5
SVH-24L	24	1120×360×375	13	2	2

SVH Base mounting dimensions

Model	L(mm)	L1(mm)	D(mm)	R(mm)
SVH-3L	120	50	40	6.5
SVH-6L	150	70	55	6.5
SVH-12L	180	80	55	6.5
SVH-24L	180	80	80	6.5

SMH Specifications

Model	Receiver			Conveying pipe dia. (inch)	Vacuum pipe dia. (inch)
	Capacity (L)	Dimension H×W×D (mm)	Weight (kg)		
SMH-6L	6	460 × 260 × 315	7	1.5	1.5
SMH-12L	12	515 × 325 × 350	7	1.5	1.5
SMH-24L	24	720 × 325 × 375	9	2	2

SMH Base mounting dimensions

	L (mm)	L1 (mm)	L2 (mm)
SMH-6L	210	180	146
SMH-12L			
SMH-24L			



SHR-U

SHR-U Series

■ Coding Principle

SHR - xU - xxx

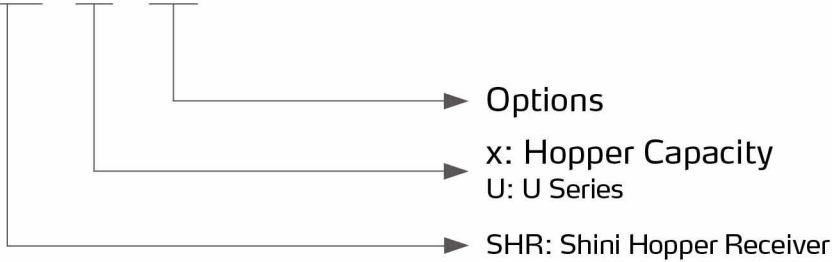

Air accumulator

■ Features

- This series of hopper receiver can work with the most of main vacuum units and Shini compact dryer SCD. SAL-UG series required 6 pins receiver, and SCD series required 4 pins receiver.
- SHR-U receiver is suitable for mounting on the dryer, storage tank, or machine hopper.
- Stainless steel hopper receiver.
- Standard equipped with steel wired mesh filter screen.

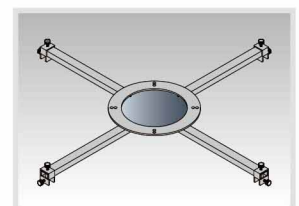

Multifunctional installation frame

■ Accessory & Options

- Multi-functional installation frame HMB suitable for other mounting application with max. 900mm adjustable diameter. Add "HMB" at the end of the model code.
- SHR-U can work with storage hopper collective hopper SCH-U/SICH-U in the direct feeding throat mounting application.
- Optional enhanced mixing technology for proportional valve SPV-U application. Add "QM" at the end of the model code.
- In case of conveying highly dusty material, SHR-12U and above can be equipped with air accumulator for auto purging function to reduce the maintenance cycle. Add "A" at the end of the model code.
- Anti-bridge option at the material outlet for SHR-48U. Applicable for flowing material but bridging from time to time only. Add "MB" at the end of the model code.

SHR-U-(E) Series

Outline Drawings

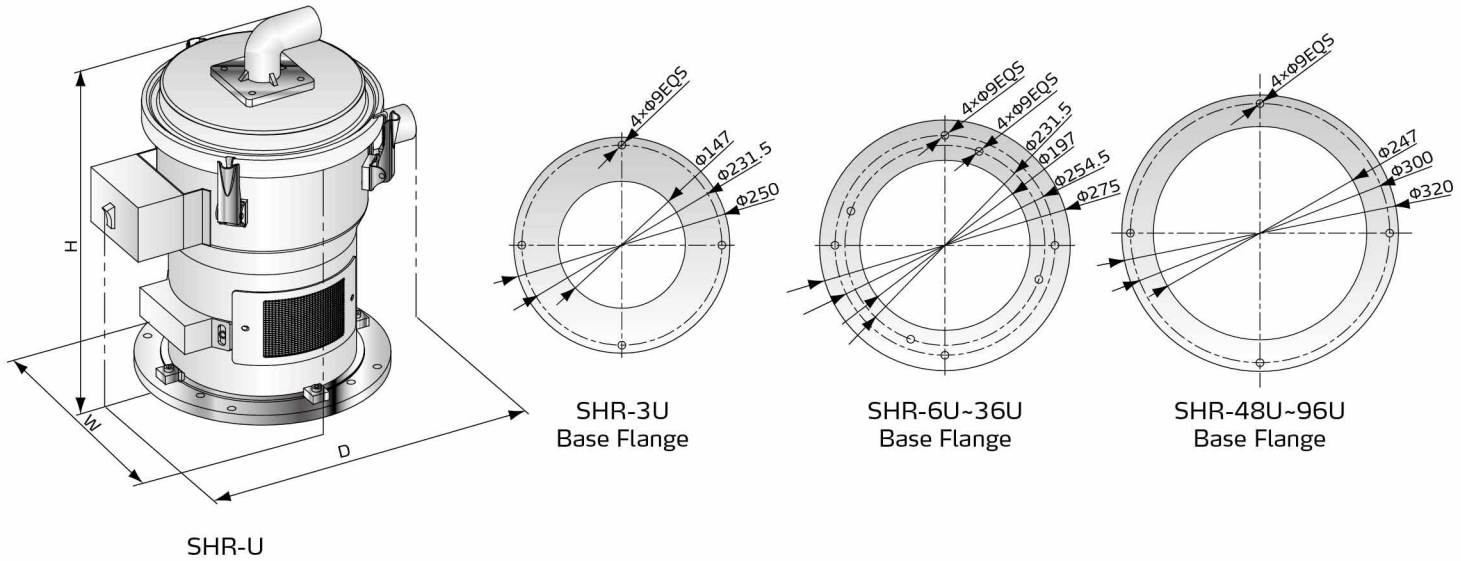

Specifications

Model	Capacity (L)	Receiver		Conveying Pipe Dia. (inch)	Vacuum Pipe Dia. (inch)
		Dimension(H×W×D) (mm)	Weight (kg)		
SHR-3U	3	380 × 250 × 330	4	1.5	1.5
SHR-6U	6	420 × 285 × 360	6	1.5	1.5
SHR-12U	12	470 × 315 × 400	7	1.5	1.5
SHR-24U	24	690 × 315 × 400	9	2	2
SHR-36U	36	930 × 315 × 400	11	2	2.5
SHR-48U	48	975 × 350 × 485	15	2.5	3
SHR-96U	96	1220 × 430 × 560	20	2.5	3



SHR-U-S

SHR-U-S(ES)-(T) Series

■ Coding Principle

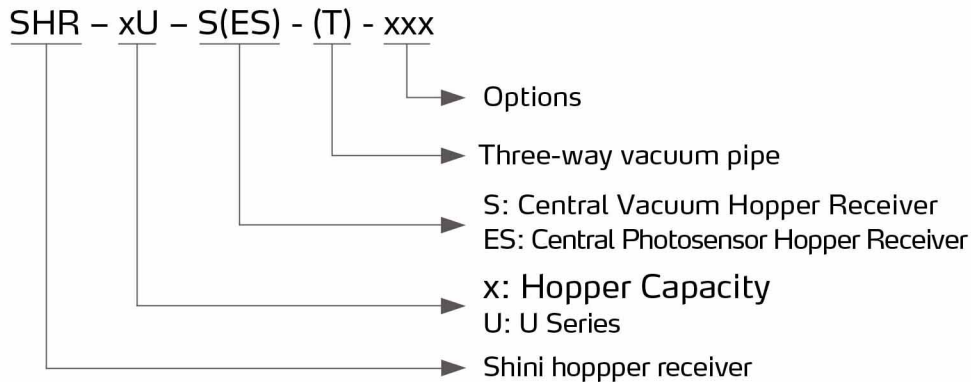

■ Features

- This series of centralized hopper receiver can work with the most of central vacuum units such as SAL-UG 122/124 and central conveying system.
- SHR-U-S receiver is suitable for mounting on the dryer, storage tank, or machine hopper.
- SHR-U-E receiver is designed to be mounted directly on feeding throat of the plastic processing machine. It required no machine hopper and kept very little dried material before the process.
- SHR-U-S-T or SHR-U-ES-T can work with multi-component batch blending or injection application. The three-way vacuum pipe allows easy connection of vacuum pipe from receiver to receiver in short proximity application.
- Stainless steel hopper receiver
- The vacuum valve is used to ensure a good vacuum line without compromising the most demanding conveying capacity.
- Standard equipped with steel wired mesh filter screen.



SHR-U-ES



SHR-U-ST

SHR-U-S/ES-(T) Series

Accessory & Options

- Multiple-functional installation frame HMB suitable for other mounting application with max. 900mm adjustable diameter. Add "A" at the end of the model code.
- SHR-U-S can work with storage collective hopper SCH-U/SICH-U in the direct feeding throat mounting application.
- The optional material one-way flap on each receiver to ensure good vacuum in the common material line conveying system. Add "RSV" at the end of the model code.
- The optional pneumatic material shut-off valve on each receiver to ensure ideal vacuum in the common material line conveying system. Add "PSV" at the end of the model code.
- The material discharge flap with extra thickness. Add "SD" at the end of the model code.
- Anti-bridge option at the material outlet for SHR-48U. Applicable for flowing material but bridging from time to time only. Add "MB" at the end of the model code.
- The optional pneumatic check valve is available for SHR-12U/24U/36U-S to avoid suck-back when the material pipe is shared by several hoppers, and add "PSV" at the end of the model code.

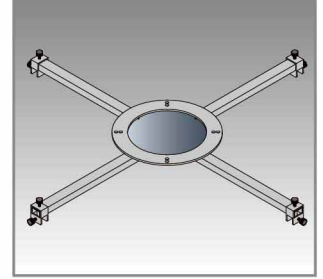

Multifunctional installation frame

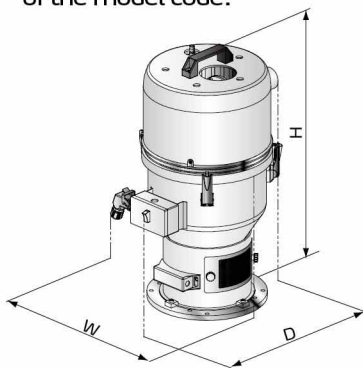

SHR-U-S

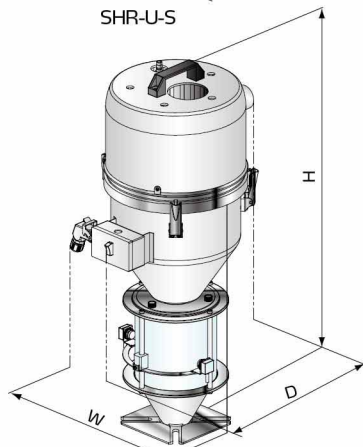

SHR-U-ES

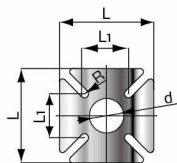

SHR-U-ES Base Flange

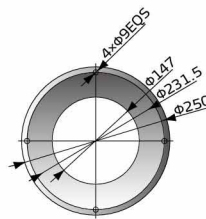

SHR-3U-S Base Flange

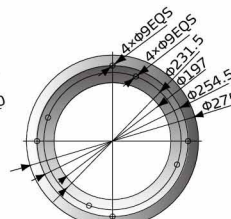

SHR-6U-S-SHR-36U-S Base Flange

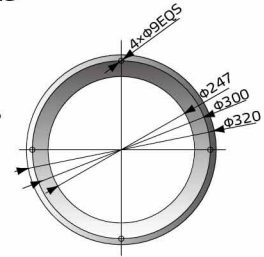

SHR-48U-S-SHR-96U-S Base Flange

SHR-U-S Specifications

Model	Capacity (L)	Receiver		Conveying Pipe Dia. (inch)	Vacuum Pipe Dia. (inch)
		Dimension (H×W×D) (mm)	Weight (kg)		
SHR-3U-S	3	600 × 270 × 340	4.5	1.5	2
SHR-3U-ES		745 × 270 × 330			
SHR-6U-S	6	560 × 305 × 375	7.5	1.5	2
SHR-6U-ES		730 × 305 × 375			
SHR-12U-S	12	615 × 335 × 405	9	1.5	2
SHR-12U-ES		810 × 335 × 405			
SHR-24U-S	24	825 × 335 × 405	11	2	2.5
SHR-24U-ES		1255 × 400 × 405			
SHR-36U-S	36	1035 × 335 × 405	12	2	2.5
SHR-48U-S	48	1140 × 400 × 480	18	2.5	3
SHR-96U-S	96	1400 × 480 × 560	23	2.5	3

SHR-U-S Base mounting dimensions

Model	L (mm)	L1 (mm)	d (mm)	R (mm)
SHR-3U-ES	120	50	40	6.5
SHR-6U-ES	150	70	55	6.5
SHR-12U-ES	180	80	55	6.5
SHR-24U-ES	180	85	80	6.5

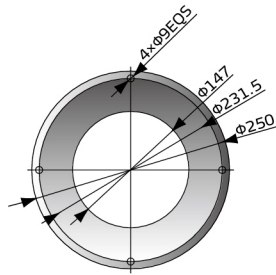
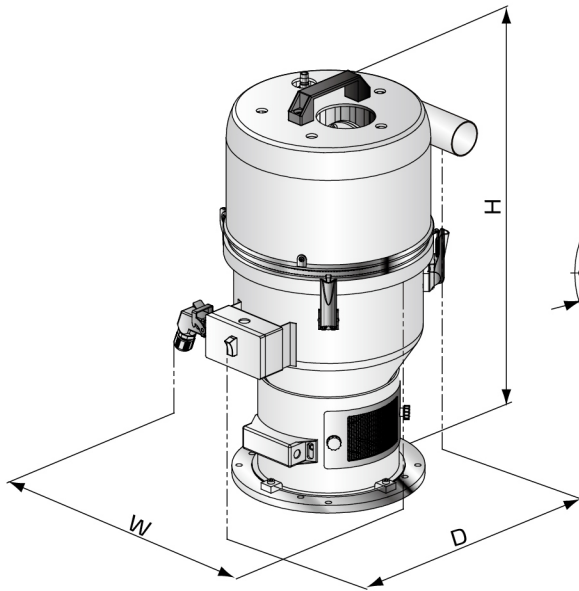

SHR-3U-ST

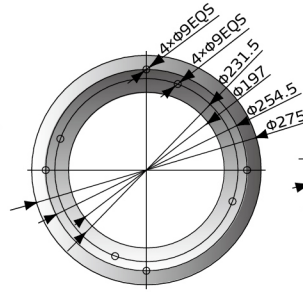

SHR-6U-S-SHR-36U-ST

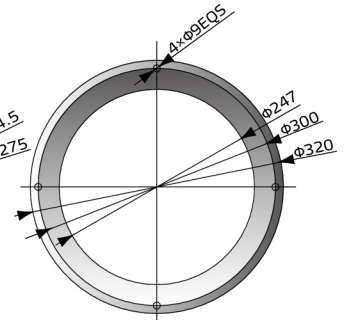

SHR-48U-S-SHR-96U-ST

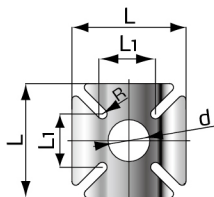
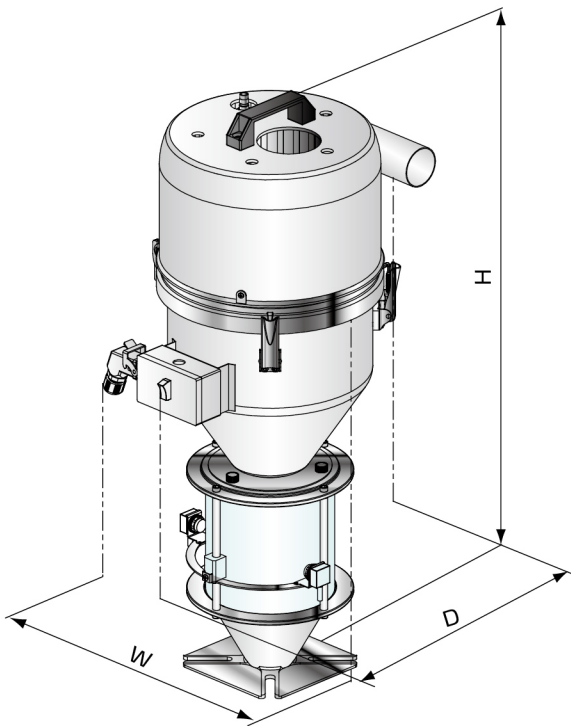

SHR-U-ST Specifications

Model	Hopper capacity (L)	Hopper		Conveying Pipe Dia. (inch)	Air Suction Pipe Dia. (inch)
		Dimension (H×W×D) (mm)	Weight (kg)		
SHR-3U-ST	3	600 × 260 × 370	4.5	1.5	2
SHR-3U-EST		745 × 235 × 370			
SHR-6U-ST	6	560 × 290 × 400	7.5	1.5	2
SHR-6U-EST		727 × 280 × 400			
SHR-12U-ST	12	615 × 305 × 440	9	1.5	2
SHR-12U-EST		810 × 305 × 440			
SHR-24U-ST	24	825 × 305 × 455	11	2	2.5
SHR-24U-EST		1255 × 400 × 455			
SHR-36U-ST	36	1035 × 305 × 455	12	2	2.5
SHR-48U-ST	48	1145 × 350 × 515	18	2.5	3
SHR-96U-ST	96	1400 × 430 × 560	23	2.5	3

SHR-U-EST Base mounting dimensions

Model	L (mm)	L1 (mm)	d (mm)	R (mm)
SHR-3U-EST	120	50	40	6.5
SHR-6U-EST	150	70	55	6.5
SHR-12U-EST	180	80	55	6.5
SHR-24U-EST	180	85	80	6.5



SHR-P-60U

SHR-P-U Series

■ Coding Principle

SHR - P - xU

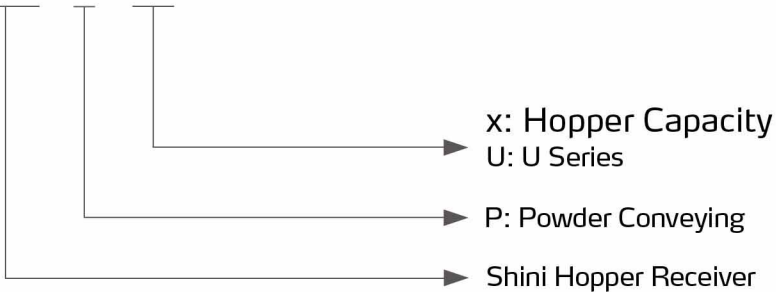

■ Features

- This series of power receiver can work with the main vacuum units such as SAL-UGP.
- SHR-P-U consists of two categories, the cloth mesh filter and the plate filter. Cloth mesh filter is used to convey materials with powder content $\leq 30\%$, plate filter is used to convey materials with powder content $> 30\%$.
- Stainless steel hopper receiver.
- The vacuum valve is used to ensure a good vacuum line without compromising the most demanding conveying capacity.
- All models equipped with auto-purge after each conveying cycle. It maintains a good conveying result and reduces maintenance.

■ Accessory & Options

- Collective hopper SCH-P-30U/60U/90U is available for SHR-P-30U/60U/90U.

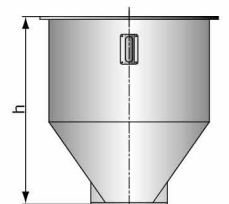

Storage Collective Hopper(Optional)

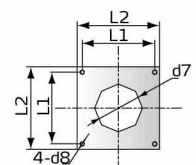

Base Flange

Outline Drawings

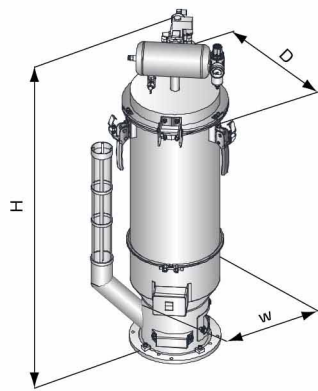

SHR-P-12U

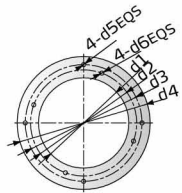

SHR-P-12U
Base Flange

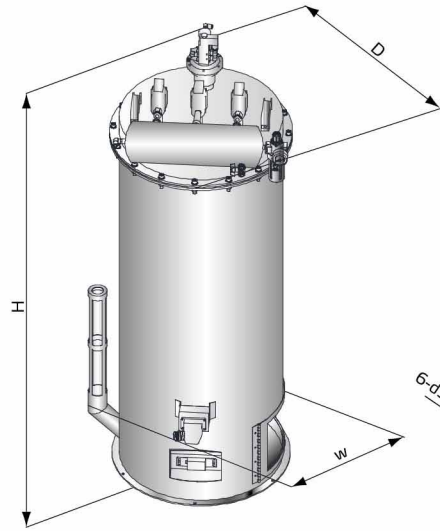

SHR-P-30U-SHR-P-90U

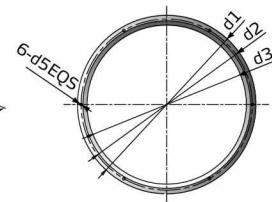

SHR-P-30U-SHR-P-90U
Base Flange

Specifications

Model	SHR-P-12U	SHR-P-30U	SHR-P-30U-1	SHR-P-30U-2	SHR-P-60U	SHR-P-60U-3	SHR-P-90U	SHR-P-90U-5
Hopper capacity (L)	12	30	30	30	60	60	90	90
H(mm)	940	1325	1325	1325	1500	1500	1640	1640
W(mm)	535	730	730	730	780	780	890	890
D(mm)	380	470	470	470	500	500	635	635
d3(mm)	Φ197	Φ430	Φ430	Φ430	Φ490	Φ490	Φ600	Φ600
d1(mm)	Φ231.5	Φ413	Φ413	Φ413	Φ475	Φ475	Φ583	Φ583
d2(mm)	Φ254.6	Φ383	Φ383	Φ383	Φ440	Φ437	Φ550	Φ550
d5(mm)	Φ271	—	—	—	—	—	—	—
d4(mm)	Φ9	Φ7	Φ7	Φ7	Φ7	Φ7	Φ9	Φ9
d6(mm)	Φ4	—	—	—	—	—	—	—
d7(mm)	—	Φ100	Φ100	Φ100	Φ127	Φ127	Φ152.4	Φ152.4
d8(mm)	—	Φ11	Φ11	Φ11	Φ11	Φ11	Φ11	Φ11
h(mm)	—	428	428	428	516	516	637	637
L1(mm)	—	180	180	180	180	180	180	180
L2(mm)	—	210	210	210	210	210	210	210
Weight(kg)	27	57	60	63	60	69	72	87
Conveying Pipe Dia. (inch)	1.5	1.5	1.5	1.5	2.0	2.0	2.5	2.5
Vacuum Pipe Dia. (inch)	1.5	1.5	1.5	1.5	2.0	2.0	2.5	2.5



SHR-CP-U



SICH-6U



SICH-12U



SICH-24U

SHR-P-U/SCH(-U)/SICH-U Series

■ Coding Principle

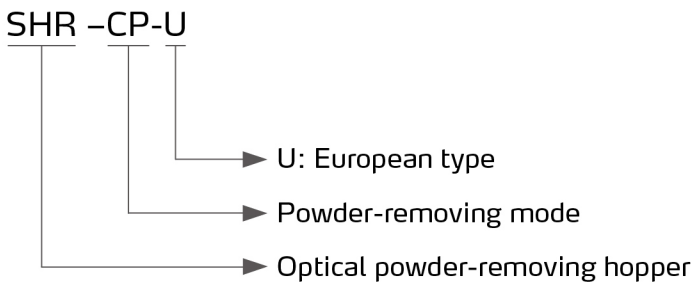

■ Features

- Mainly work with Compact Dryer SCD-OP
- It can remove the powder in the material to avoid stains generating in the molding process.
- Adopts stainless steel SUS304 to ensure no material contamination
- Standard equipped with adjustable level sensor

■ Specifications

Model	Hopper					Conveying Pipe Dia. (inch)	Air Suction Pipe Dia. (inch)
	Hopper capacity (L)	Dust-removing efficiency	Handling capacity (kg/hr)	Dimension (H×W×D) (mm)	Weight (kg)		
SHR-CP-3U	3	80%	10	820 × 280 × 305	8	1.5	1.5

■ Outline Drawings

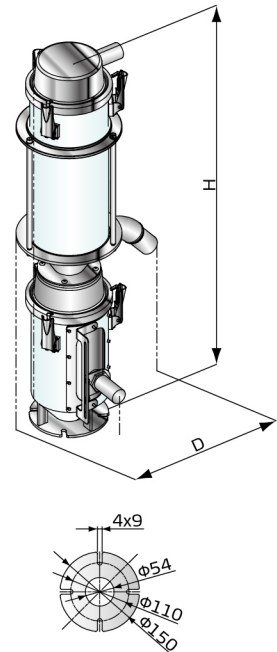

Base Flange

SCH(-U)/SICH-U Series

Coding Principle

S(I)CH - xU

x: Hopper Capacity
U: European Type

SCH: Shini Storage Collective Hopper
SICH: Shini Heat-insulated Collective Hopper

Features

- SCH-U and SICH-U are mainly to work with the SHR-U vacuum hopper receiver and SHR-U-S U series central vacuum hopper receiver
- Heat-insulated collective hopper SICH-U ensures temperature decrease no more than 30°C within 30 minutes
- SCH-U and SICH-U are made of stainless steel, which ensure no material contamination

Outline Drawings

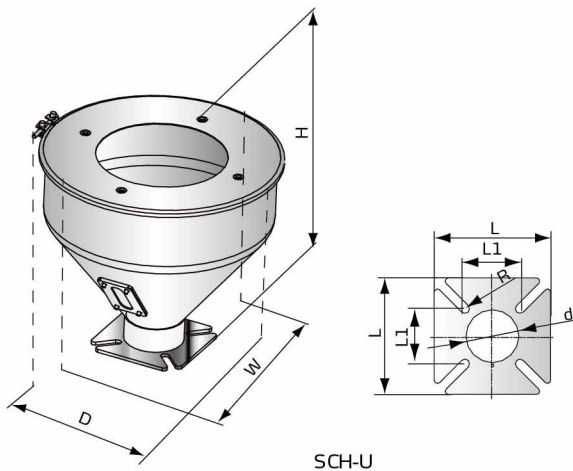
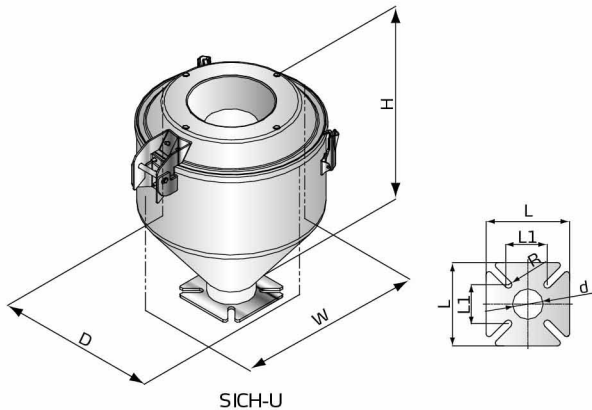

Specifications

SICH-U

Model	Hopper capacity (L)	Dimension (H×W×D) (mm)	Weight (kg)
SICH-6U	6	340 × 345 × 300	8
SICH-12U	12	425 × 405 × 350	11
SICH-24U	24	535 × 490 × 430	15

SICH-U Base Flange

Model	L(mm)	L1(mm)	d(mm)	R(mm)
SICH-6U	150	81	51.5	6.5
SICH-12U	150	81	55	6.5
SICH-24U	180	85	64.5	6.5

SCH-U

Model	Hopper capacity (L)	Dimension (H×W×D) (mm)	Weight (kg)
SCH-6U	6	257 × 300 × 317	4.5
SCH-12U	12	314 × 362 × 381	7
SCH-24U	24	329 × 404 × 423	9
SCH-36U	36	448 × 404 × 423	11

SCH-U Base Flange

Model	L(mm)	L1(mm)	d(mm)	R(mm)
SCH-6U	150	80	58.5	6.5
SCH-12U	150	80	58.5	6.5
SCH-24U	180	85	81.5	7
SCH-36U	180	85	81.5	7