

Flexible Screw Feeder

SSC-50 & MST-S



Refer carefully to this manual before operation.

■ Coding Principle

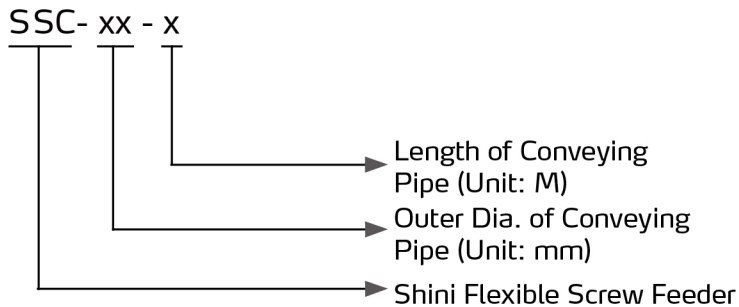

Material Outlet

■ Features

- Effectively avoid material stratification during conveying process
- Fully closed conveying line, free from contamination
- Flexible conveying line brings maximum convenience of installation, best compatibility with other conveying equipments, no wearing due to friction and other material blockage.
- Reverse phase protector is adopted to avoid that the motor is incapable of conveying materials because of motor reversal.
- Standard conveying pipeline is 5mm/197.5 inch which can reach be lengthened to 7mm/276 inch.

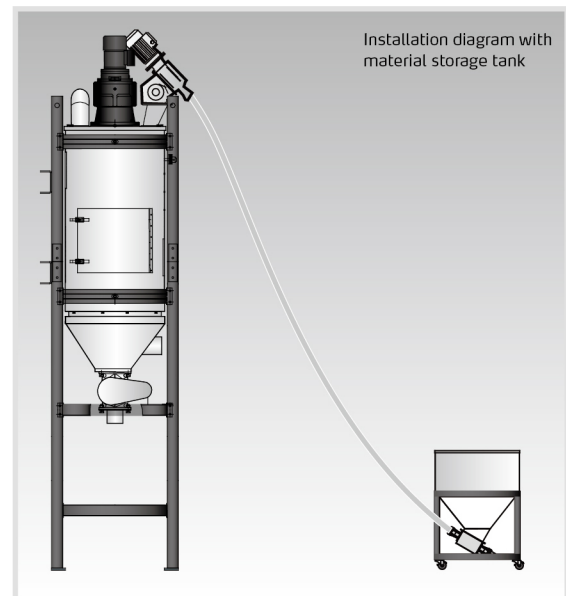

■ Application

SSC series flexible screw feeders adopt motor-driven screws for raw material conveying, applicable to convey regrinds, virgin materials, powders and their mixtures with features of easy installation and maintenance. It can work with other Shini's products, such as PET crystallizer, and blender (must be mounted on the customized flange). Two models of SSC-50/65 available with max. horizontal conveying capacity of up to 1,900 kg/hr (4,189 lb/hr).

SSC Series

Outline Drawings

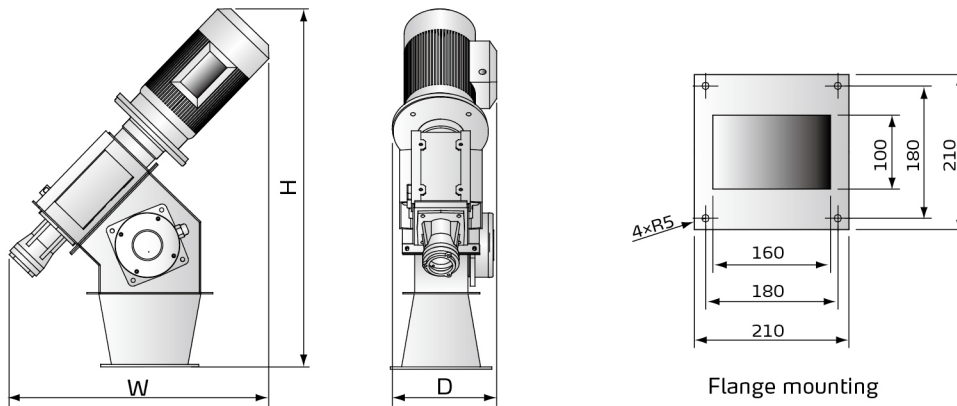

Specifications

Model	Outer Dia.		Motor Power (kW, 50/60Hz)	Motor Rotating Speed (rpm, 50/60Hz)	Radius		Bulk Density		Material	Conveying Capacity(50/60Hz)					
	mm	inch			mm	inch	kg/L	lb/gal		A=0°		A=45°			
SSC-50	Φ 50	Φ2	0.75/0.85	910/1090	1,500	59	0.8	6.7	Pellet	800/	1,764/	700/	1,543/		
										900	1,984	840	1,852		
							0.7	5.8		Powder	450/	992/	350/	772/	
									540	1,190	420	926			
									Sheet	300/	661/	250/	551/		
										360	794	300	661		
SSC-65	Φ 65	Φ2.5	1.1/1.26	910/1090	1,500	59	0.8	6.7	Pellet	1,900/	4,189/	1,400/	3,086/		
												2,280	5,026	1,680	3,074
							0.7	5.8		Powder	1,000/	2,205/	800/	1,543/	
										1,200	2,646	960	2,116		
									Sheet	600/	1,323/	500/	1,102/		
										720	1,587	600	1,323		

Notes: 1) It is suitable for material conveying pipeline less than 7m/23Feet; The spring is inclined to fracture once the pipeline is more than 7meters/23Feet.

- 2) Bending radius of conveying pipeline should be more than 1.5m/59inch and its bending angle should be more than 120° to prevent overload, material blockage or spring fracture.
- 3) To be conveyed granule dia. : For SSC-50, it should be less than 4mm/0.16inch and for SSC-65, it should be less than 6mm/0.24inch or material could easily get stuck. Also we suggest not use it to convey flakes with more than 15mm in/0.59inch length.
- 4) Power supply: 3Φ, 230/400/460/575V, 50/60Hz.