

# Central Vacuum Generators

SCVG



## Application

In central conveying system, central vacuum generator will provide vacuum (negative pressure) power. This machine adopts high pressure blower or Roots blower as its core power, which has features like heavy-duty, great power and long service life etc to ensure continuously loading. Besides, this series offer more than 11 models with maximum 15 HP applicable to different system applications. The start of the blower is controlled via central control station and can work with equipments like Euro vacuum central hopper and central filter to realize automatic material loading function.

## Outline Drawings

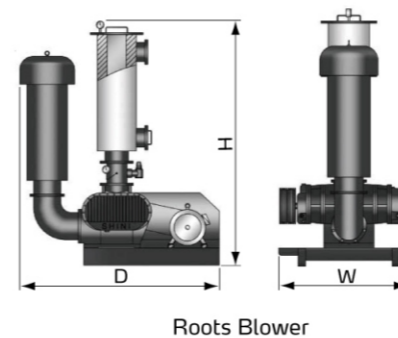
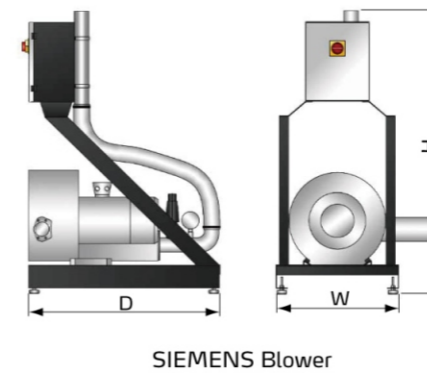
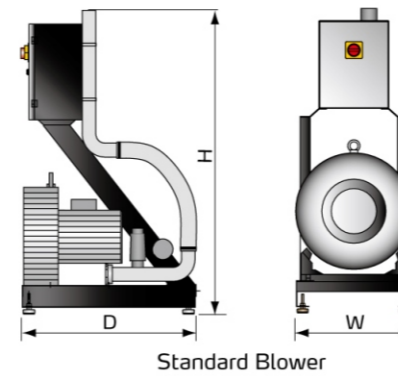

## Specifications

Model	Motor Power (kW, 50/60Hz)	Air Suction Pipe Dia. (Inch)	Dimensions (mm)H×W×D	Weight (kg)
SCVG-035-SS	2.2/2.6	2	1125×420×650	60
SCVG-050-SS	3.75/4.3	2	1125×420×650	64
SCVG-050-DS			1125×653×650	
SCVG-075-SS	5.5/6.3	2.5	1210×460×700	105
SCVG-075-DS			1210×682×700	
SCVG-100-SS	7.5/8.6	2.5	1210×460×700	106
SCVG-100-DS			1210×682×700	
SCVG-150-SS	9/10.3	2.5	1300×560×930	128

Note: 1) "SS" stands for single stage blower, "DS" stands for double stage blower.  
2) Power supply: 3Φ, 230/400/460/575VAC, 50/60Hz.

Model	Motor Power (kW, 50/60Hz)	Air Suction Pipe Dia. (Inch)	Dimensions (mm)H×W×D	Weight (kg)
SCVG-050-SS	4/4.5	2	1244×793×540	72
SCVG-050-DS			1190×655×793	83
SCVG-075-SS	5.5/6.3	2.5	1244×540×793	156
SCVG-075-DS			1304×693×910	193
SCVG-100-SS	7.5/8.6	2.5	1244×540×793	158
SCVG-100-DS			1304×693×910	200
SCVG-150-DS	9/11	3	1424×693×996	235

Note: 1) "SS" stands for single stage blower, "DS" stands for double stage blower.  
2) Power supply: 3Φ, 230/400/460/575VAC, 50/60Hz.

Model	Motor Power (kW, 50/60Hz)	Air Suction Pipe Dia. (Inch)	Dimensions (mm)H×W×D	Weight (kg)
SRB-65-V	3.7-5.5/4.2-6.3	2	1120×660×860	350
SRB-80-V	3.7-7.5/4.2-8.6	3	1195×690×1060	400
SRB-100-V	5.5-11/6.3-13	4	1195×820×1060	480
SRB-125-V	7.5-18/8.6-20.7	5	2000×900×1285	600
SRB-125A-V	11-22/13-25.3	5	2000×875×1285	640
SRB-150-V	15-30/17.2-34.5	6	2040×985×1300	680

Note: 1) "V" stands for vacuum.  
2) Applicable to various kinds of motors.  
3) Power supply: 3Φ, 230/400/460/575VAC, 50/60Hz.