



Granulating & Recycling

Belt Conveyor

Simple Solution



Belt Conveyor

■ Coding Principle

PNL - x - Lxxxx

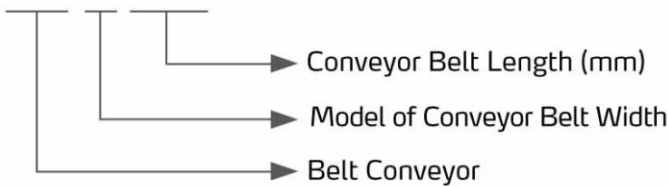

PNL - MS - Lxxx

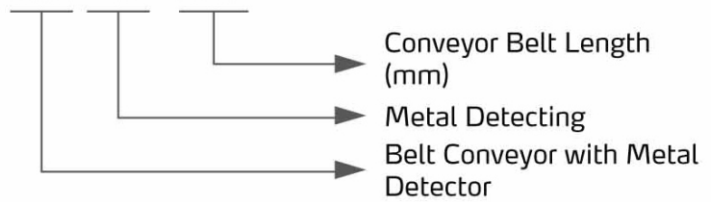

CB - x

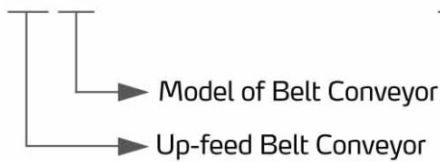

CBD -x



SV -x



■ Features

- Mounted on patented "FUTURE" floor stand.
- PVC belt is adopted for smooth and efficient conveying.
- Height adjustable floor stand. PNL series 1~2m/39.4"~78.7" meters of conveying belt has angel adjustable function with a range of 0°~25°.
- CB series has material fence to facilitate regrind conveying, optionally available for PNL series.
- Sidewalls for PNL-MS series, CB (CBD) series, SV series and PNL series are 100mm/3.9", 95mm/3.7", 34 mm/1.3" and 75mm/3" respectively.
- The conveying speed of CB, CBD, PNL and SV series is 6.5m/min .
- Equipped with channel metal detector to detect effectively the metal in the channel.
- PNL-MS series conveying speed could be adjusted within 1.3~8 m/min (4.3~26.2feet/min) by transducer which is standard configuration.
- Maximum loading capacity of CB, CBD, PNL, SV series is 56kg, PNL-MS series is 150kg/331lb.
- Frequency converter is standard for CB, CBD, PNL, SV series , of which the normal and safe speed range is 3~6.5 m/min.
- PNL-MS-L3500 minimum detectable diameter (metal ball) is $\Phi 5\text{mm}/0.2"$.
- PNL-MS-L4500 minimum detectable diameter (metal ball) is $\Phi 8.7\text{mm}/0.34"$.
- Power supply for CB, CBD, PNL and SV series are 1 Φ , 230VAC, 50Hz/ 60Hz.
- Power supply for PNL-MS series are 3 Φ , 400VAC, 50Hz/ 60Hz.



CBD-12



PNL-2



PNL-MS-L3500



SV-1

Application

Shini manufactures five models of belt conveyors as follows under technical license from a leading european manufacturer:

PNL series conveyors feature reliable performance and ease of operation and are suitable for use with CB or SV series conveyors or as stand-alone units.

PNL-MS series belt conveyor with metal detector is a device which can detect the metal contained in the material during conveying and simultaneously activate the alarm.

CBD series conveyors feature reliable performance and ease of operation and are suitable for conveying finished products to separator to separate product from its connecting sprues. The height is adjustable.

SV series conveyors feature reliable performance and ease of operation and are suitable for conveying.

Outline Drawings

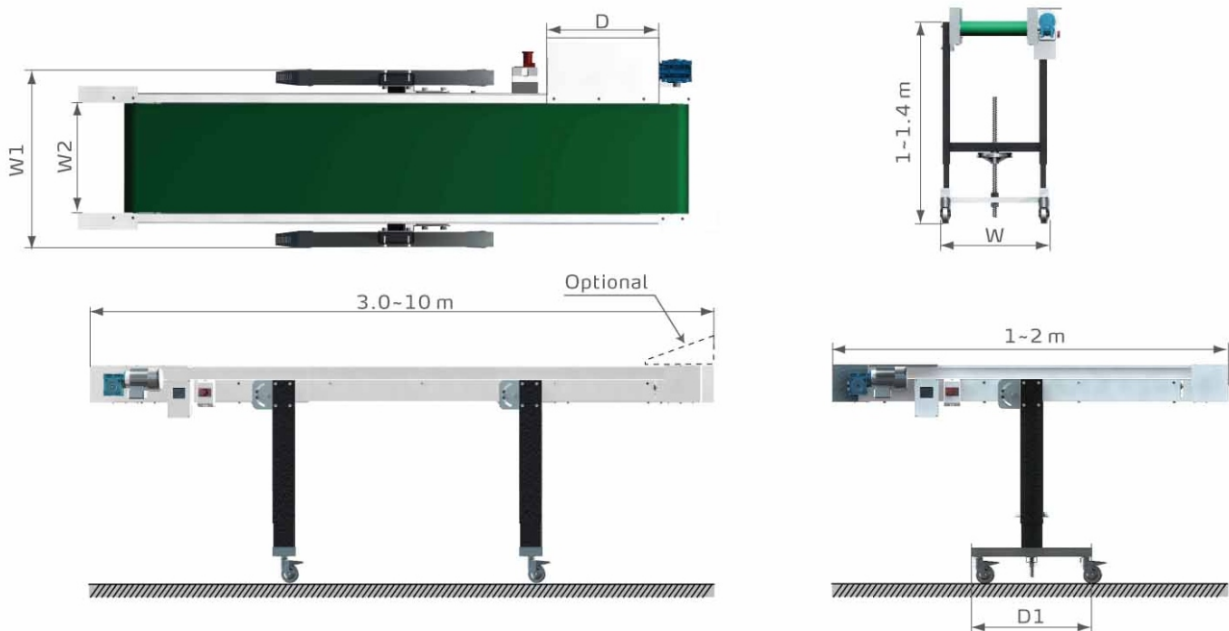

PNL Outline Drawings

Model		PNL-1	PNL-2	PNL-3	PNL-4	PNL-5	PNL-6	PNL-7	PNL-8
W	mm	440	520	590	720	820	1020	1220	1420
	inch	17.3	20.5	23.2	28.3	32.3	40.2	48	55.9
W1	mm	450	530	600	730	830	1030	1230	1430
	inch	17.7	20.9	23.6	28.7	32.7	40.6	48.4	56.3
W2	mm	220	300	370	500	600	800	1000	1200
	inch	8.7	11.8	14.6	19.7	23.6	31.5	39.4	47.2
D	mm	500	500	500	500	500	500	500	500
	inch	19.7	19.7	19.7	19.7	19.7	19.7	19.7	19.7
D1	mm	650	650	650	650	650	650	650	650
	inch	25.6	25.6	25.6	25.6	25.6	25.6	25.6	25.6
Weight	kg	93	100	106	117	126	143	160	180
	lb	205	221	234	258	278	315	353	397

We reserve the right to change specifications without prior notice.

Belt Conveyor

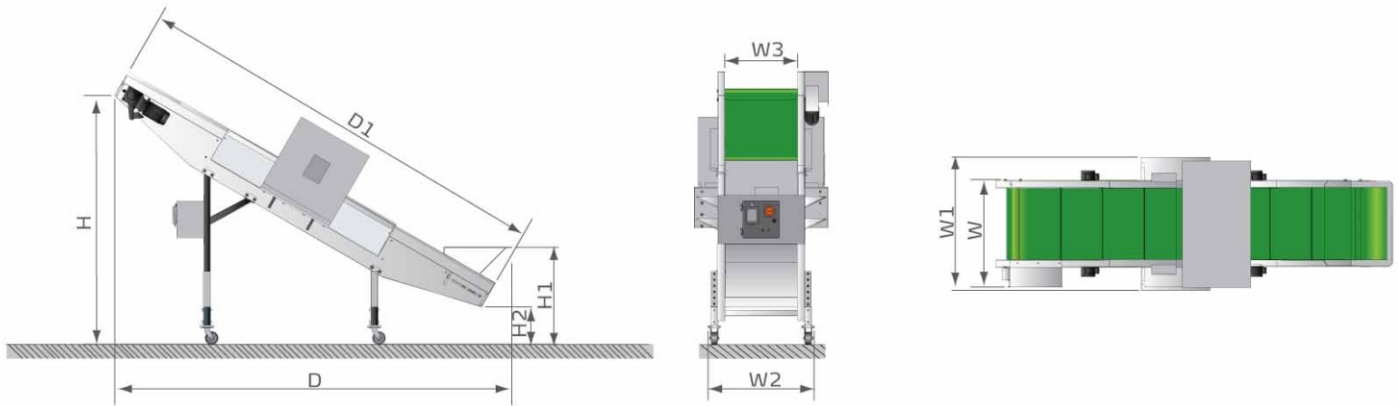

PNL-MS Outline Drawings

Model		PNL-MS-L3500	PNL-MS-L4500
W	mm	895	1295
	inch	35.2	51
W1	mm	1105	1505
	inch	43.5	43.5
W2	mm	880	1280
	inch	34.6	50.4
W3	mm	600	1000
	inch	23.6	39.4
D	mm	3285	4150
	inch	129.3	163.4
D1	mm	3500	4500
	inch	137.8	177.2
H	mm	2110	2560
	inch	83	100.8
H1	mm	855	805
	inch	33.7	31.7
H2	mm	350	310
	inch	13.8	12.2
Weight	kg	420	670
	lb	926	1477

We reserve the right to change specifications without prior notice.

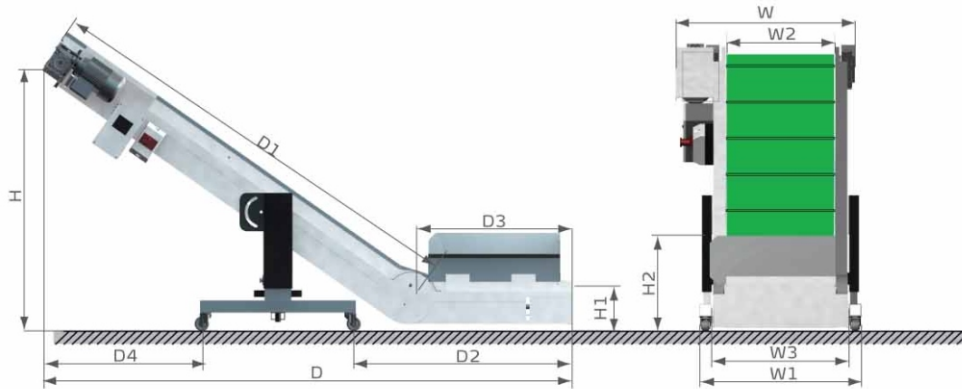

CB Outline Drawing

Model		CB-1	CB-2	CB-3	CB-4	CB-5	CB-6
H	mm	940+65	940+65	940+65	1168+145	1168+145	1168+145
	inch	37+2.6	37+2.6	37+2.6	46+5.7	46+5.7	46+5.7
H1	mm	262+65	262+65	262+65	200+145	200+145	200+145
	inch	10.3+2.6	10.3+2.6	10.3+2.6	7.9+5.7	7.9+5.7	7.9+5.7
H2	mm	405+65	405+65	405+65	343+145	343+145	343+145
	inch	15.9+2.6	15.9+2.6	15.9+2.6	13.5+5.7	13.5+5.7	13.5+5.7
W	mm	533	603	733	533	603	733
	inch	21	23.7	28.9	21	23.7	28.9
W1	mm	483	553	683	483	553	683
	inch	19	21.8	26.9	19	21.8	26.9
W2	mm	250	320	450	250	320	450
	inch	9.8	12.6	17.7	9.8	12.6	17.7
W3	mm	359	429	559	359	429	559
	inch	14.1	16.9	22	14.1	16.9	22
D	mm	1815	1815	1815	2225	2225	2225
	inch	71.5	71.5	71.5	87.6	87.6	87.6
D1	mm	1300	1300	1300	1800	1800	1800
	inch	51.2	51.2	51.2	70.9	70.9	70.9
D2	mm	845	845	845	909	909	909
	inch	33.3	33.3	33.3	35.8	35.8	35.8
D3	mm	690	690	690	690	690	690
	inch	27.2	27.2	27.2	27.2	27.2	27.2
D4	mm	520	520	520	665	665	665
	inch	20.5	20.5	20.5	26.2	26.2	26.2
Weight	kg	92	102	112	100	100	120
	lb	203	225	247	220	220	265

We reserve the right to change specifications without prior notice.

Belt Conveyor

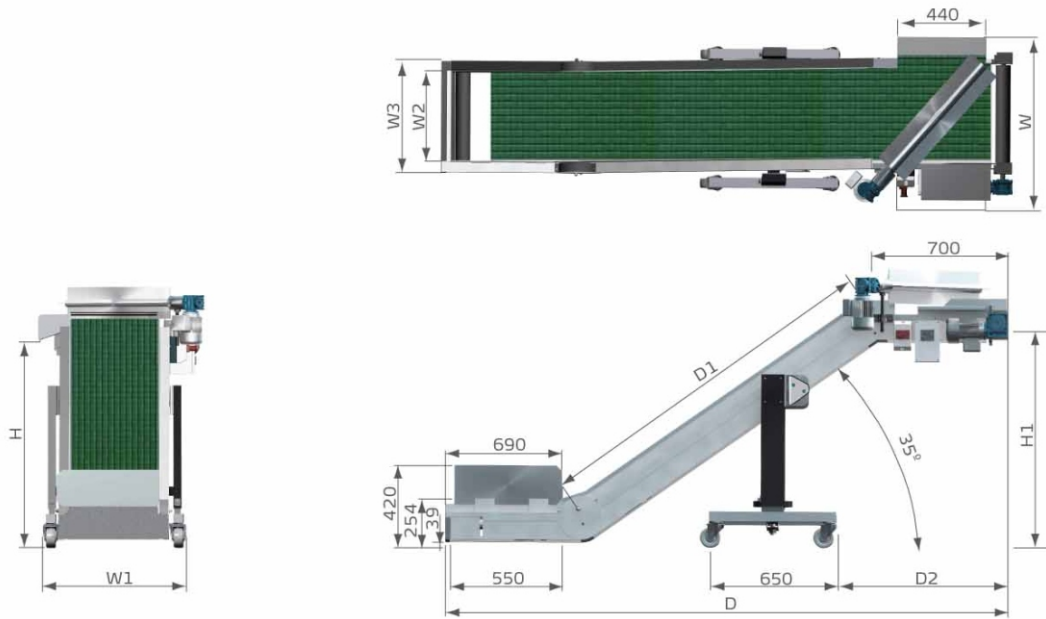

CBD Outline Drawings

Model		CBD-7	CBD-8	CBD-9	CBD-10	CBD-11	CBD-12
H	mm	855+70	855+70	855+70	1140+140	1140+140	1140+140
	inch	33.6+1.32	33.6+1.32	33.6+1.32	44.9+5.51	44.9+5.51	44.9+5.51
H1	mm	797+70	797+70	797+70	1083+140	1083+140	1083+140
	inch	31.4+2.76	31.4+2.76	31.4+2.76	42.6+5.51	42.6+5.51	42.6+5.51
W	mm	650	730	880	650	730	880
	inch	25.6	28.7	34.6	25.6	28.7	34.6
W1	mm	506	576	706	506	576	706
	inch	19.9	22.8	27.8	19.9	22.8	27.8
W2	mm	250	320	450	250	320	450
	inch	9.8	12.6	17.7	9.8	12.6	17.7
W3	mm	358	428	558	358	428	558
	inch	14.1	16.9	22.0	14.1	16.9	22.0
D	mm	2455	2455	2455	2865	2865	2865
	inch	96.7	96.7	96.7	112.8	112.8	112.8
D1	mm	1300	1300	1300	1800	1800	1800
	inch	51.2	51.2	51.2	70.9	70.9	70.9
D2	mm	747	747	747	870	870	870
	inch	29.4	29.4	29.4	34.3	34.3	34.3
Weight	kg	130	140	155	135	150	169
	lb	287	309	342	298	331	373

We reserve the right to change specifications without prior notice.

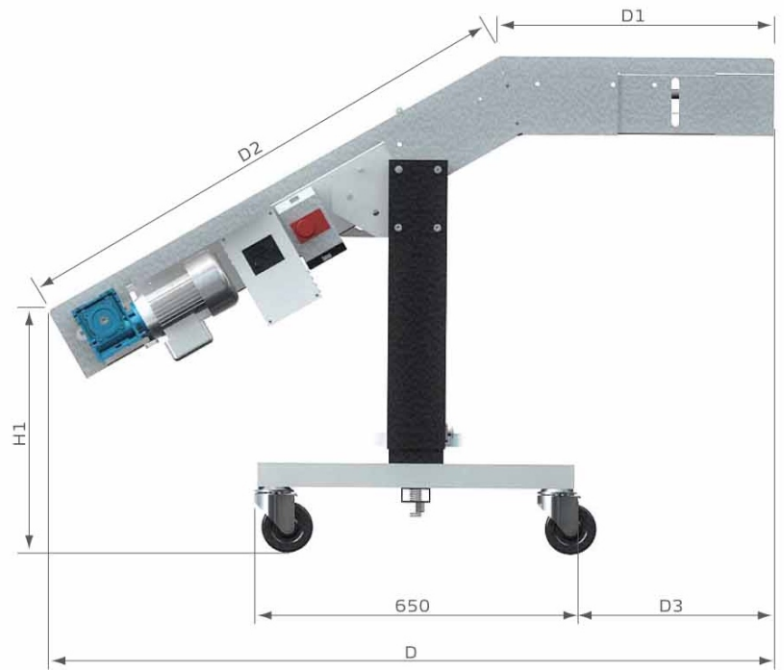
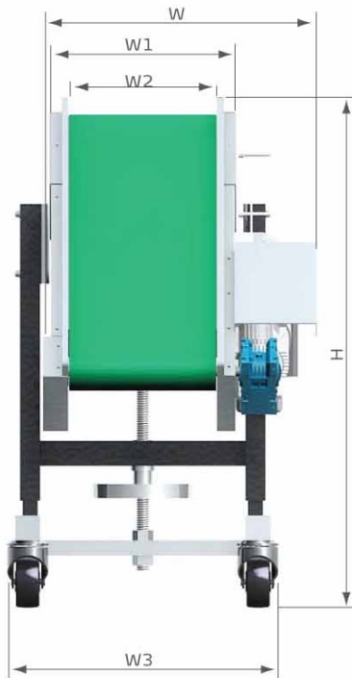

SV Outline Drawings

Model		SV-1	SV-2	SV-3	SV-4	SV-5	SV-6
H	mm	1000-1400	1000-1400	1000-1400	1250-1650	1250-1650	1250-1650
	inch	39.4-55.1	39.4-55.1	39.4-55.1	49.2-65.0	49.2-65.0	49.2-65.0
H1	mm	525-925	525-925	525-925	525-925	525-925	525-925
	inch	20.7-36.4	20.7-36.4	20.7-36.4	20.7-36.4	20.7-36.4	20.7-36.4
W	mm	550	620	750	620	750	850
	inch	21.7	24.4	29.5	24.4	29.5	33.5
W1	mm	371	441	571	441	571	671
	inch	14.6	17.4	22.5	17.4	22.5	26.4
W2	mm	300	370	500	370	500	600
	inch	11.8	14.6	19.7	14.6	19.7	23.6
W3	mm	490	560	690	560	690	790
	inch	19.3	22.0	27.2	22.0	27.2	31.1
D	mm	1480	1480	1480	1910	1910	1910
	inch	58.3	58.3	58.3	75.2	75.2	75.2
D1	mm	564	564	564	564	564	564
	inch	22.2	22.2	22.2	22.2	22.2	22.2
D2	mm	1062	1062	1062	1562	1562	1562
	inch	41.8	41.8	41.8	61.5	61.5	61.5
D3	mm	410	410	410	480	480	480
	inch	16.1	16.1	16.1	18.8	18.8	18.8
Weight	kg	83	88	93	110	120	130
	lb	183	194	205	243	265	287

We reserve the right to change specifications without prior notice.

Shini Group

Addr: No. 23, Minhe St., Shulin Dist.,
New Taipei, Taiwan

Tel: +886 2 2680 9119

Fax: +886 2 2680 9229

Email: shini@shini.com

Factories:

- Taiwan
- Dongguan
- Pinghu
- Ningbo
- Chongqing
- Pune

2018-07-15-04 Copyrights Reserved.

www.shini.com