



High Temp. Water Heater

STM-607PW



Refer carefully to this manual before operation.

STM-PW Series

■ Coding Principle

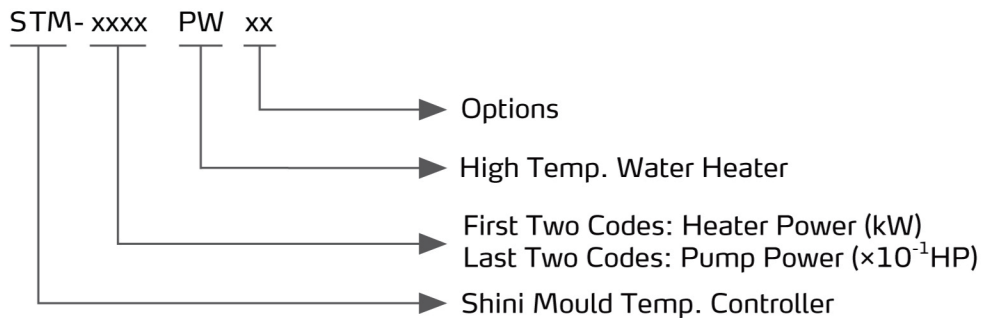

■ Features

- For standard STM-PW, the maximum heating temperature is 180°C/356°F.
- 4.3" Touch screen controller with easy to use HMI and clean display.
- Adopt SSR solid-state relay controller.
- Adopt plate heat exchanger for direct cooling and accurate temperature control, and the low water viscosity makes quick heat exchange.
- P.I.D controller with 4.3" LCD with a user-friendly interface. The multi-stage controller can maintain stable mould temperature with a precision of +/- 0.5°C/0.9°F.
- In build weekly timer with °C/°F. unit conversion.
- In build multiple safety with display and alarm buzzer, such as reverse phase, pump overload, overheat, and low water pressure.
- Built-in magnetic pump without seal.
- RS485 communication interface achieves centralized monitoring with the host.
- Equipped with water level probe and high-pressure plunger pump that could accurately detect the water level, and refill during high-pressure as to avoid empty water system.

■ Options

- For models optional with magnetic filter to prolong the service life the magnetic pump, and add "MF" at the end of the model code.
- For models optional with mold temperature and mold return water temperature display, and add "TS" at the end of the model code.
- For models optional with air-blowing function, add "A" at the end of the model code.
- For models optional with the circuit breaker, add "CB" at the end of the model code.

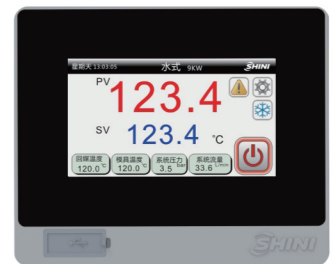

Control Panel

■ Application

STM-PW series high temp. water heaters are mainly used for mold heating and mold temperature maintaining. Besides, it is also applicable to fields with other similar demands. Compared with the STM-W water heater, this series is able to meet wider production demands under higher heating temperature (180°C) condition. Besides, there are many options and accessories for this series of machine that can meet different production demands.

■ Performance Curve

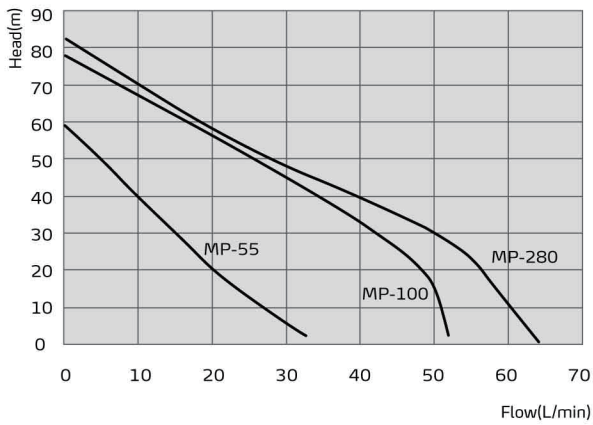

50Hz-cycles/2800r/min-rpm-tr/min

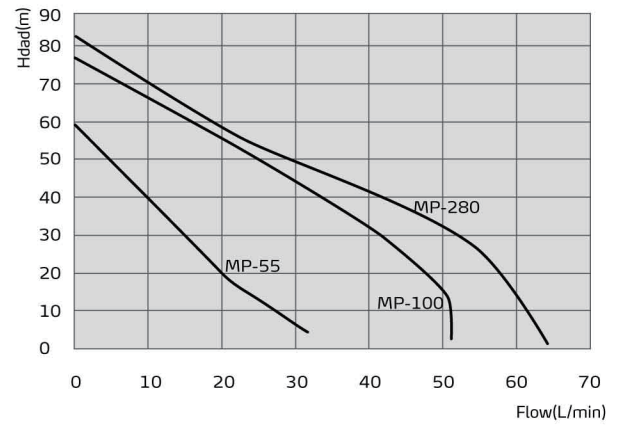

60Hz-cycles/3400r/min-rpm-tr/min

■ Working Principle

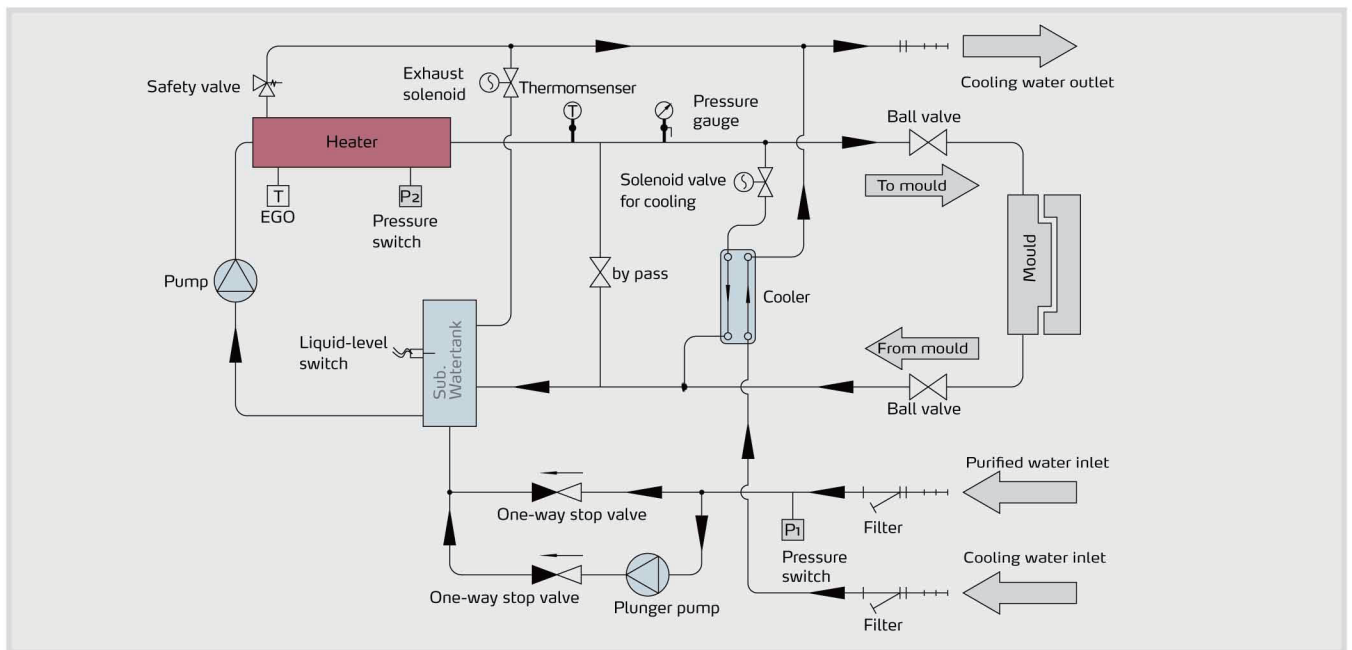

STM-PW System flow chart

STM-PW Series

Specifications

Model		STM-607PW	STM-607PW-D	STM-1220PW	STM-2440PW
Max.Temp.		180 ⁰ C/356 ⁰ F			
Heater(kW)		6	6×2	12	24
Pump Power(kW) (50/60Hz)		0.6/0.69	0.6×2/0.69×2	1.05/1.2	2.9/3.4
Max. pump Flow (50/60Hz)	L/min	25.5/28	25.5/28	50/60	100/120
	gal/min	6.7/7.4	6.7/7.4	13.2/15.8	26.4/31.7
Max. pump Pressure(bar)(50/60Hz)		4.8/6.3	4.8×2/6.3×2	5.8/7.6	8/10.5
Heating Tank Number		1	2	1	2
Heating Tank Capacity	L	3.4	3.2×2	3.4	6.2
	gal	0.9	0.9	0.9	1.64
Sub. water tank Capacity	L	1.4	1.4	1.4	1.8
	gal	0.37	0.37	0.37	0.48
CoolingMethod		Indirect			
Inlet/Outlet (inch)		3/4 / 3/4	3/4 / 3/4	3/4 / 3/4	1 / 1
Dimensions (H×W×D)	mm	690×320×910	750×620×990	690×320×990	950×450×1050
	inch	27.2×12.5×35.8	29.5×24.4×39	27.2×12.5×39	37.4×17.7×41.3
Weight	kg	80	185	95	140
	lb	176	408	209	309

- Notes: 1) To ensure stable water temperature, cooling water pressure should not be less than 2kgf/cm², but also no more than 5kgf/cm².
 2) Pump testing standard: Power of 50/60Hz, purified water at 20°C/68°F. (There is ±10% tolerance for either max. flowrate or max. pressure).
 3) Power supply: 3Φ, 230/400/460/575VAC, 50/60Hz.

We reserve the right to change specifications without prior notice.

Shini Group

Addr: No. 23, Minhe St., Shulin Dist.,
New Taipei, Taiwan

Tel: +886 2 2680 9119

Fax: +886 2 2680 9229

Email: shini@shini.com

Factories:

- Taiwan
- Dongguan
- Pinghu
- Ningbo
- Chongqing
- Pune