



## Metal Detecting Separator

SMS



Refer carefully to this manual before operation.

## ■ Coding Principle

SMS - xx

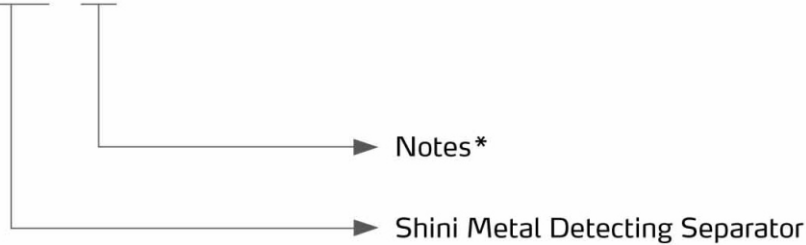

Notes:\*

CE=CE Conformity

## ■ Features

### Standard configuration

- Fast separating all the metals from the material.
- The minimum detectable diameter of the metals can be as short as 0.5mm.
- Compact design, easy to install and simple to operate.
- When it installed on the injection molding machine or on hopper of the extruder, material level sensor should be mounted on the hopper to prevent material blockage which affects machine testing.
- Standard equipped with a 12L/3.2gal hopper.

### Accessory option

- Specific size of hoppers and floor stands can be customized to meet any requirements.

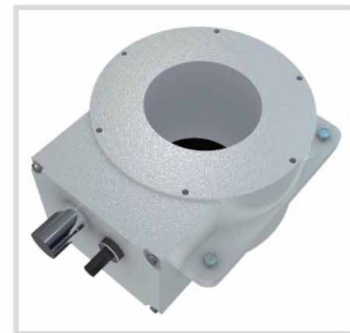

Metal Detecting Separator

## ■ Application

SMS series metal detecting separators are highly sensitive and accurate in detecting and separating metal grains, such as steel, iron, copper, aluminum, lead, tin, etc. Its principle is when metal impurities passing through it, electrical detector can send a signal to control board to open the valve to discharge the impurity materials. Pneumatic discharging system takes little space and ensures good performance. It can be installed directly on injection molding machine or (extruders) hoppers to protect the screw of machine from the damage caused by hard metals. Its processing capacity is ranging from 600L/hr(159gal/hr) to 3,000L/hr(792.5gal/hr) to meet any specific requirements.

## Working Principle

Material discharge pipe has a ring-type metal detector sleeved on and when material with no metal impurities passing through it, no signal will be sent out from the detector to activate the separating flap from its standby position. Thus material will flow out via the passage showed in Fig. 1.

However when material with metal impurities passing through it, signal will be sent out from the detector to move the separating flap to the other position. Thus material will flow out via the passage showed in Fig. 2.

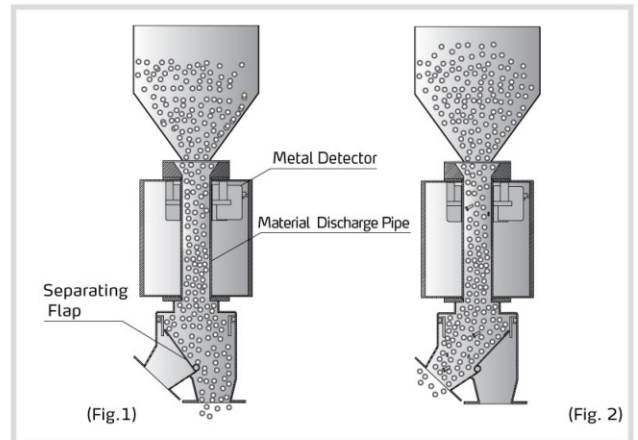

## Outline Drawings

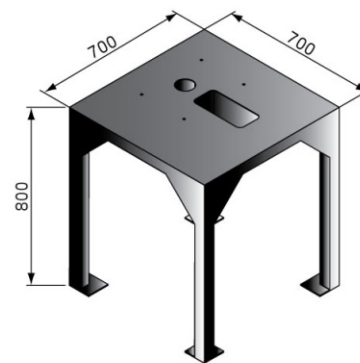
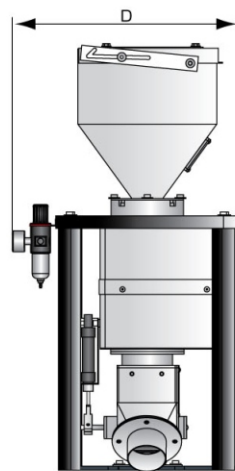
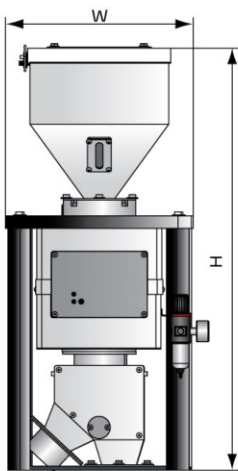

Floor Stand Dimensions

## Specifications

Model		SMS-35	SMS-50	SMS-70
Maximum Throughput	L/hr	600	1,500	3,000
	gal/hr	159	396	793
Minimum Detectable Diameter	mm	0.5	0.6	1.0
	inch	0.02	0.02	0.04
Material outlet pipe diameter	mm	35	50	70
	inch	1.38	1.97	2.76
Dimensions H × W × D	mm	860 × 405 × 368	860 × 405 × 368	860 × 405 × 368
	inch	33.9 × 15.9 × 14.5	33.9 × 15.9 × 14.5	33.9 × 15.9 × 14.5
Weight	kg	50	50	50
	lb	110	110	110

- Notes: 1) Testing result of maximum throughput is based on particles of 0.8kg/L(6.7lb/gal) in bulk density and 2~3mm/0.12~0.2" in size.  
 2) The minimum metal diameter is detected based on carbon steel testing standard.  
 3) Power supply: 1Φ, 115/230VAC, 50/60Hz.

We reserve the right to change specifications without prior notice.

## Shini Group

Addr: No. 23, Minhe St., Shulin Dist.,  
New Taipei, Taiwan

Tel: +886 2 2680 9119

Fax: +886 2 2680 9229

Email: [shini@shini.com](mailto:shini@shini.com)

### Factories:

- Taiwan
- Dongguan
- Pinghu
- Ningbo
- Chongqing
- Pune

2017-03-15-04 Copyrights Reserved.

[www.shini.com](http://www.shini.com)