



Three Axes Servo Driven Robot

ST3-900-1600



Refer carefully to this manual before operation.

ST3 Series



■ Coding Principle

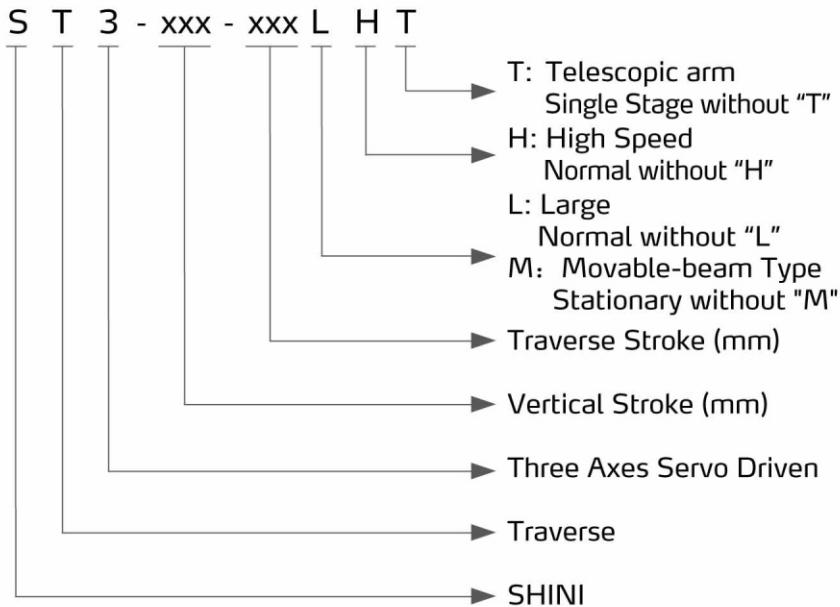

Control Panel



ST3-700-1400HT



ST3-700-1400T



ST3-1400-2200MT

■ Features

- Appearance
Designed with elegant appearance; Aluminium profiles are largely used to provide compact and streamlined appearance.
- Precision
All linear movements are driven by heavy duty servo motors with cooperation of precise linear guide rails and high power V belts; Fast, silent, and precise. Wrist mechanism employs pneumatic driven rack and pinion system, which accomplishes smooth, stable and precise flipping motion. Vertical arm with telescopic design efficiently minimizes the cycle time and height of the robot.
- Safety
Position limit sensors and blocks effectively prevent mechanical and electrical malfunctions. Control board is designed to CE EMC test with short circuit and noise proof functions.
- Convenience
Control hardware fixtures are designed with flyer structure which provides benefit to maintenance. Cable drag chains help with cable management and ease for maintenance.

ST3 Series

- Standardization

All pneumatic accessories, electric accessories, and communication Protocols meet the global standards. Interface between injection molding machine and robot is designed to EUROMAP 12, EUROMAP 67 and SPI.

- Intelligence

Base on VARAN BUS technology with world class 8.4 inch true color touch screen and object oriented program editor, complex and continuous projection can be easily programmed within minimum time. Closed circuit control system cooperating with plug and use hardware modules provides reliable movement that is capable of arranging, stacking, quality checking, in mold inserting etc. Real time remote monitoring and telediagnosis assist better equipment management. USB port allows fast data updating, saving and loading.

- User Friendly

Plug and use industrial connectors achieve simple mount and demount. Servo driven axis provides the possibility of multi points for positioning products and sprues. Multi languages displays and spaces communication connections with surrounds machines offer more flexibilities to global customers.



ST3-1200-1800MT



Flip Cylinder

■ Applications

The ST3 series robot is designed for rapid and precise removal of products from injection molding machine, and place them at desired locations. Standard and telescopic arm are selectable to cooperate with 2-plate mold or hot runner system. Capable of arranging, stacking, quality checking and in mold placement. Suitable for injection molding machine under 3600T clamp force. ST3-MT particularly for refrigerator and air conditioner casing and automobile accessories.

■ Outline Drawings

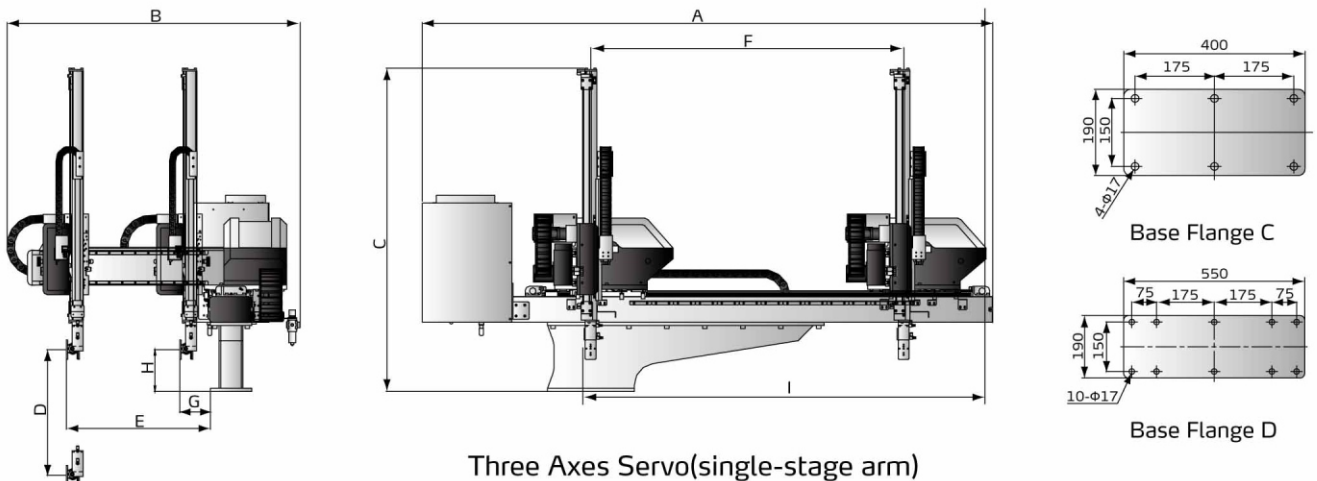

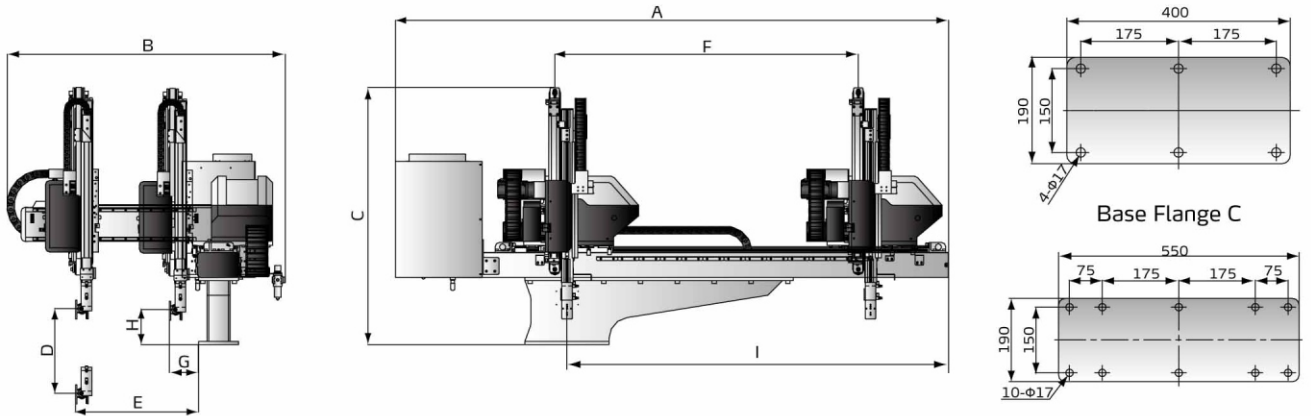

Three Axes Servo Telescopic

Base Flange D

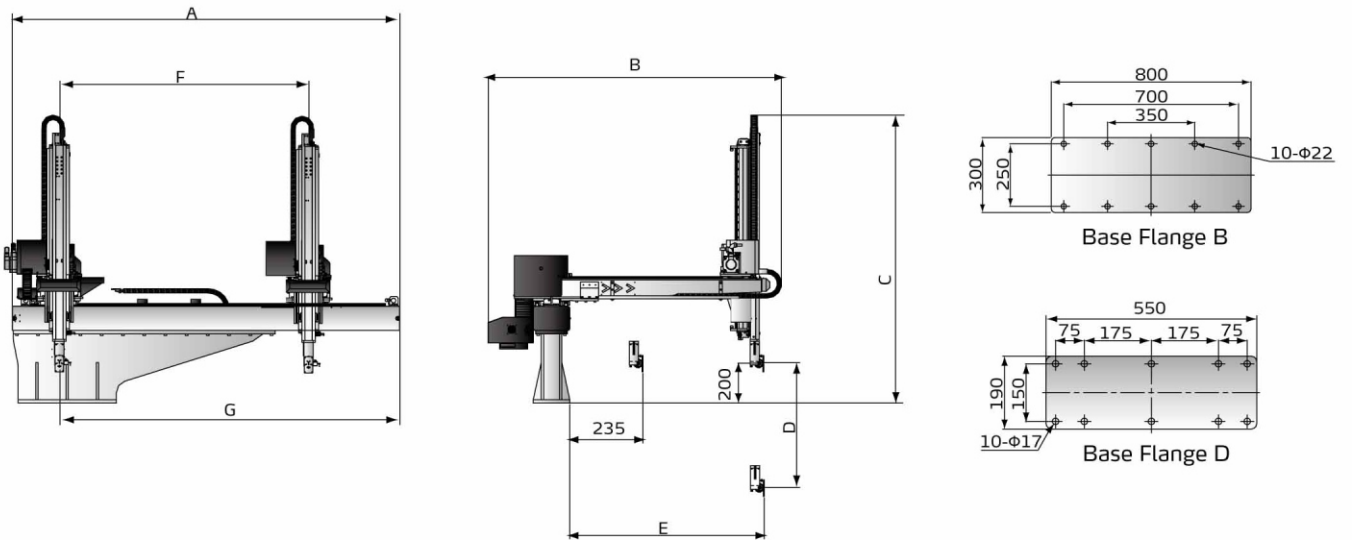

Three Axes Servo Medium Telescopic (Stationary-beam type)

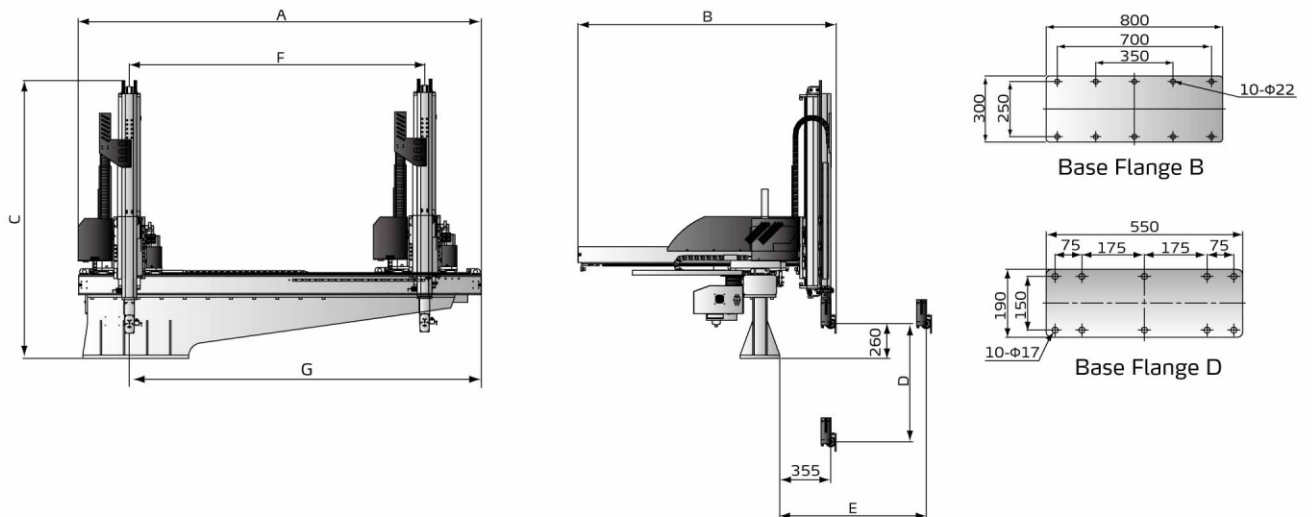

ST3-MT Three Axes Servo Medium Telescopic (Movable-beam Type)

ST3 Series

Specifications

ST3-MT (Movable-beam type)		ST3-1200- 1800MT	ST3-1300- 2000MT	ST3-1400- 2000MT	ST3-1500- 2200MT	ST3-1600- 2200MT	ST3-1700- 2200MT
IMM (ton)		300~450T	450~600T	450~600T	600~700T	700~850T	700~850T
Traverse Stroke (mm)		1800	2000	2000	2200	2200	2200
Crosswise Stroke (mm)		800	800	900	900	1000	1000
Vertical Stroke (mm)		1200	1300	1400	1500	1600	1700
Rated(Max)Load (with tool)(kg)		10(15)	10(15)	10(15)	10(15)	20(30)	20(30)
Min. Pickout Time (sec)		2.8	3	3	3.2	3.3	3.4
Min. Cycle Time (sec)		12	12.5	13	13.5	14	15
Air Pressure (bar)		4~6	4~6	4~6	4~6	4~6	4~6
Max. Air Consumption (Nl/cycle) *		6	6	6	6	6	6
Weight (kg)		480	500	530	550	580	600
Base Type		Base D	Base D	Base D	Base B	Base B	Base B
Dimension (mm)	A	2847	3047	3047	3247	3247	3247
	B	1617	1617	1717	1717	1817	1817
	C	1790	1840	1890	1940	2020	2070
	D(max)	1200	1300	1400	1500	1600	1700
	E(max)	1155	1155	1255	1255	1355	1355
	F(max)	1800	2000	2000	2200	2200	2200
	G	2250	2450	2450	2650	2650	2650

ST3-MT (Medium Open Telescopic)		ST3-1800-2400MT	ST3-1900-2400MT	ST3-2000-2800MT	ST3-2100-2800MT	ST3-2200-3000MT
IMM (ton)		850~1400T	850~1400T	1400~1800T	1400~1800T	1800~2400T
Traverse Stroke (mm)		2400	2400	2800	2800	3000
Crosswise Stroke (mm)		1200	1200	1200	1400	1400
Vertical Stroke (mm)		1800	1900	2000	2100	2200
Rated(Max)Load (with tool)(kg)		20(30)	20(30)	20(30)	20(30)	20(30)
Min. Pickout Time (sec)		3.6	3.6	3.8	3.8	4
Min. Cycle Time (sec)		16	17	17.5	18	19
Air Pressure (bar)		4~6	4~6	4~6	4~6	4~6
Max. Air Consumption (Nl/cycle) *		6	6	6	6	6
Weight (kg)		650	670	690	720	750
Base Type		Base B	Base B	Base B	Base B	Base B
Dimension (mm)	A	3447	3447	3847	3847	4047
	B	2017	2017	2017	2270	2270
	C	2120	2170	2220	2270	2320
	D(max)	1800	1900	2000	2100	2200
	E(max)	1555	1555	1555	1755	1755
	F(max)	2400	2400	2800	2800	3000
	G	2850	2850	3250	3250	3450

Notes: 1). "M" stands for middle mold detector (suitable for three-plate mold).

"EM12" stands for EUROMAP 12 communication interface.

"EM67" stands for EUROMAP 67 communication interface.

"N" stands for non-operation side, operation side without "N"

2) " * " Extra 60Nl/min for vacuum application.

3) Power supply: 1Φ, 200~240V, 50/60Hz.

We reserve the right to change specifications without prior notice.



ST3-LT (Large Telescopic)	ST3-1800-2400LT	ST3-2000-2800LT	
IMM (ton)	850 ~ 1400T	1400 ~ 1800T	
Traverse Stroke (mm)	2400	2800	
Crosswise Stroke (mm)	1340	1500	
Vertical Stroke (mm)	1800	2000	
Rated(Max)Load (with tool)(kg)	40(60)	40(60)	
Min. Pickout Time (sec)	3.8	4.0	
Min. Cycle Time (sec)	20	22	
Air Pressure (bar)	4 ~ 6	4 ~ 6	
Max. Air Consumption (NI/cycle) *	8	8	
Weight (kg)	920	950	
Dimension (mm)	A	3800	4200
	B	2500	2650
	C	2400	2500
	D (max)	1800	2000
	E (max)	1750	1900
	F (max)	2400	2800
	G	2900	3300

ST3-LT (Large Telescopic)	ST3-2200-3000LT	ST3-2600-3200LT	ST3-3000-3400LT	
IMM (ton)	1800 ~ 2400T	2400 ~ 3000T	3000 ~ 3600T	
Traverse Stroke (mm)	3000	3200	3400	
Crosswise Stroke (mm)	1500	1660	1820	
Vertical Stroke (mm)	2200	2600	3000	
Rated(Max)Load (with tool)(kg)	40(60)	40(60)	40(60)	
Min. Pickout Time (sec)	4.2	4.5	5.0	
Min. Cycle Time (sec)	24	26	28	
Air Pressure (bar)	4 ~ 6	4 ~ 6	4 ~ 6	
Max. Air Consumption (NI/cycle) *	8	8	8	
Weight (kg)	990	1010	1080	
Dimension (mm)	A	4400	4600	4800
	B	2650	2820	2980
	C	2600	2800	3000
	D (max)	2200	2600	3000
	E (max)	1900	2050	2250
	F (max)	3000	3200	3400
	G	3500	3700	3900

Notes: 1). "M" stands for middle mold detector (suitable for three-plate mold).

"EM12" stands for EUROMAP 12 communication interface.

"EM67" stands for EUROMAP 67 communication interface.

"N" stands for non-operation side, operation side without "N"

2) " * " Max. air consumption for vacuum device 60NI/min.

3) Power supply: 1Φ, 200~240V, 50/60Hz.

We reserve the right to change specifications without prior notice.

Shini Group

Addr: No. 23, Minhe St., Shulin Dist.,
New Taipei, Taiwan

Tel: +886 2 2680 9119

Fax: +886 2 2680 9229

Email: shini@shini.com

Factories:

- Taiwan
- Dongguan
- Pinghu
- Ningbo
- Chongqing
- Pune

2017-08-15-04 Copyrights Reserved.

www.shini.com