



Three/Five Axes Servo Driven Robot (Driven-control integrated)

ST5-800-1400DT-S2-I



Refer carefully to this manual before operation.

■ Coding Principle

ST3/5 - xxx - xxx DT - S - I

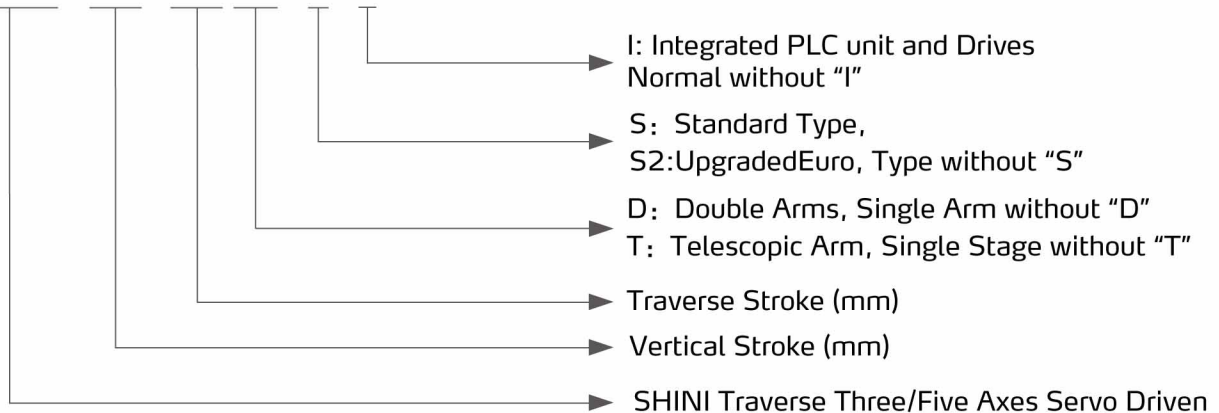

■ Features

- Advanced driver ensures stable performance;
- Highly modular design and card split structure makes it only has to change corresponding module without disassembling and replacing the whole machine during maintenance, which is better than most of other drive-control units in the market.
- The shared DC bus makes the driver work more stably, with better overload capacity. Moreover, it only needs a regenerative resistor, which saves mount space.
- The main control module and the servo module are connected in the unified base plate, which avoid cumbersome manual wiring and increases the system's stability and reliability;
- The servo parameters can be set by the control plate automatically;
- The bus controlled interface is suitable for all kinds of IMMs (national, European and Japanese standards), suitable for new 8" manipulator;
- It not only features the split stability, but also saves the labor works of wiring, and it shortens the size of the control box.

■ Application

Thina series robot is designed for rapid and precise removal of products from injection molding machine, and place them at desired locations. Apply to 2/3-plate mold or hot runner system. Capable of arranging, stacking, quality checking and in mold placement. Suitable for injection molding machine with clamping force 80~300 tons.

ST3/5 Series

Outline Drawings

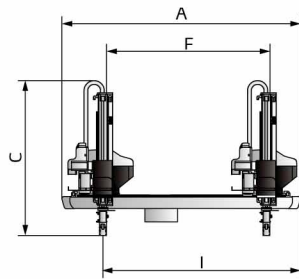
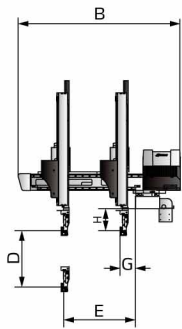

3-axis servo with single kick-stroke beam

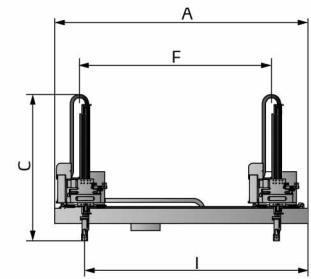
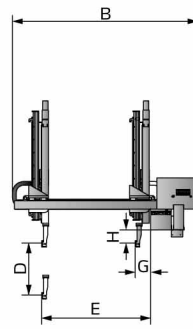

3-axis telescopic arm with frame type beam

Specifications

Model		ST3-800-1400T-S2-I	ST3-1000-1600T-S2-I	ST3-1200-1800T-S2-I
Robot Type		Single kick stroke beam	Single kick stroke beam	Telescopic arm with frame type beam
IMM (ton)		80-160	220-300	320-450
Traverse Stroke (mm)		1400	1600	1800
Crosswise Stroke (mm)	Main Arm	700	900	1100
	Sub. Arm	-	-	-
Vertical Stroke (mm)	Main Arm	800	1000	1200
	Sub. Arm	-	-	-
Max Load (with tool) (kg)		5	5	6
Min Pick-out Time (sec)		1.3	1.4	1.5
Min Cycle Time (sec)		5.2	5.5	6.5
Air Pressure (bar)		4~6	4~6	4~6
Max. Air Consumption (NL/cycle)*		4	4	4
Weight (kg)		250	300	320
Dimensions (mm)	A	2060	2300	2600
	B	1400	1600	2000
	C	1240	1360	1500
	D	800	1000	1200
	E	680	680	850
	F	1400	1600	1800
	G	180	180	250
	H	190	190	270
	I	1730	1730	2200

Notes: 1) "M" stands for middle mold detector. (suitable for three-plate mold.)

"EM12" stands for EUROMAP 12 communication interface.

"EM67" stands for EUROMAP 67 communication interface.

"N" stands for non-operation side, operation side without "N"

2) Power supply: 1Φ, 200-240V, 50/60Hz.

3) * * * Max. air consumption for vacuum device 60NL/min."

Outline Drawings

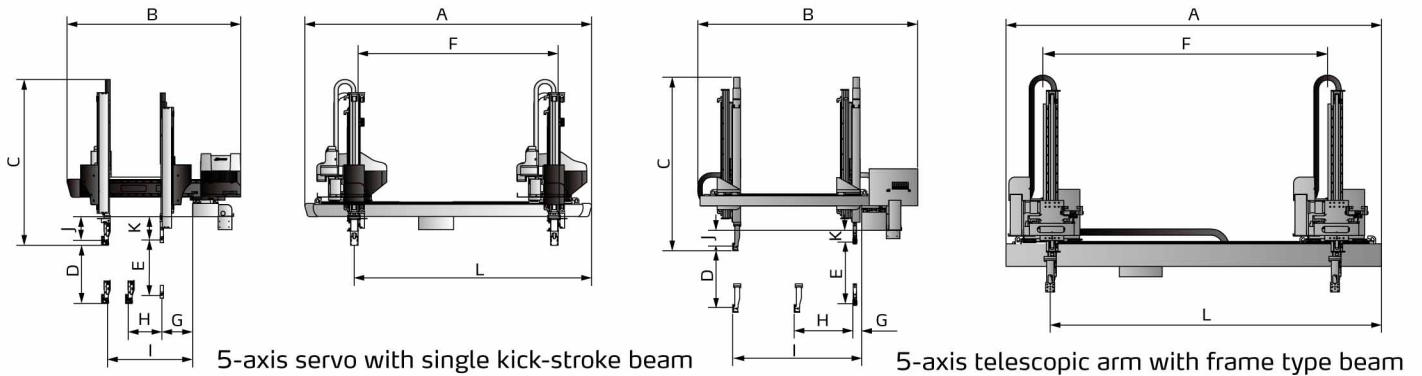

Specifications

Model		ST5-800-1400DT-S2-I	ST5-1000-1600DT-S2-I	ST5-1200-1800DT-S2-I
Robot Type		Single kick stroke beam	Single kick stroke beam	Telescopic arm with frame type beam
IMM (ton)		80-160	220-300	320-450
Traverse Stroke (mm)		1400	1600	1800
Crosswise Stroke (mm)	Main Arm	500	700	850
	Sub. Arm	500	700	850
Vertical Stroke (mm)	Main Arm	800	1000	1200
	Sub. Arm	800	1000	1200
Max Load (with tool) (kg)		5	5	6
Min Pick-out Time (sec)		1.3	1.4	1.5
Min Cycle Time (sec)		5.2	5.5	6.3
Air Pressure (bar)		4-6	4-6	4-6
Max. Air Consumption (NI/cycle)*		4	4	4
Weight (kg)		290	320	340
Dimensions (mm)	A	2060	2300	2600
	B	1400	1400	2000
	C	1240	1360	1500
	D	800	800	1200
	E	800	800	1200
	F	1400	1600	1800
	G	180	180	250
	H	110	110	220
	I	680	680	950
	J	200	200	270
	K	190	190	250
	L	1730	1930	2200

Notes: 1) "M" stands for middle mold detector. (suitable for three-plate mold.)
 "EM12" stands for EUROMAP 12 communication interface.
 "EM67" stands for EUROMAP 12 communication interface.
 "N" stands for non-operation side, operation side without "N"
 2) Power supply: 1Φ, 200-240V, 50/60Hz.
 3) * * Max. air consumption for vacuum device 60NI/min. "

Shini Group

Addr: No. 23, Minhe St., Shulin Dist.,
New Taipei, Taiwan

Tel: +886 2 2680 9119

Fax: +886 2 2680 9229

Email: shini@shini.com

Factories:

- Taiwan
- Dongguan
- Pinghu
- Ningbo
- Chongqing
- Pune

2022-11-15-04 Copyrights Reserved.

www.shini.com