



## Standard Swing-arm Robot 1

SS-650-S1



Refer carefully to this manual before operation.

# SS-S1 Series



## ■ Coding Principle

S S - xxx T - S1



Hand Controller

## ■ Features

- Appearance  
Designed with elegant appearance; Aluminium profiles are largely used to provide compact and streamlined appearance.
- Base Mechanism  
Fast mold changing design provides simple method for changing molds. The base is rotatable for 90° by releasing the handle.
- Control System  
Dialogic hand controller provides English, Japanese, Traditional Chinese and Simplified Chinese. Other languages are applicable; up to 8 different languages can be stored. There are 8 standard programs and memory for up to 50 customized programs with self fault detection. Swing directions are adjustable simply by flipping the switch on the control board. Position limit sensors are applied to all moving directions in order to provide safety mechanically and electrically. Extra 4 sets of I/O pins are available for other applications. Designed to EUROMAP 12, EUROMAP 67 and SPI to provide plug and use.

## ■ Application

The SS-S1 series robot is designed for rapid and precise removal of sprue and runner from injection molding machine, and place them into granulator for recycling. Simple product removal is applicable with optional vacuum generator and EOAT. Suitable for injection molding machine under 250T clamp force.

## ■ Options



Middle Mold Detector

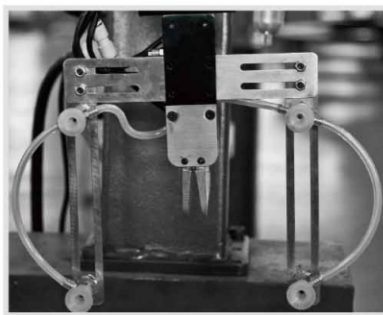

Vacuum Device



Rotate Wrist

# SS-S1 Series

## Outline Drawings

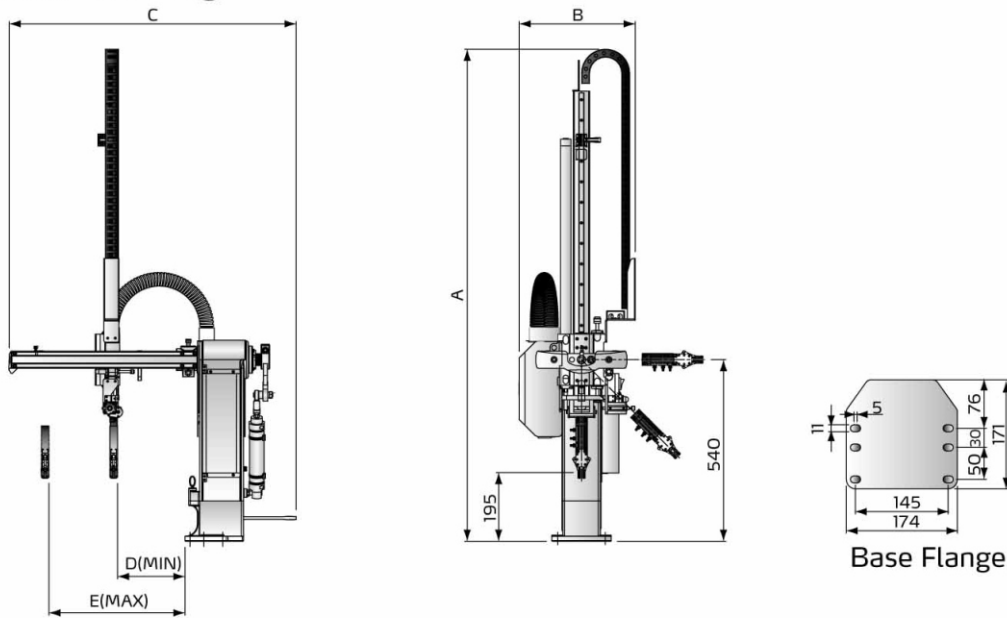

## Specifications

Model	SS-650-S1	SS-650T-S1	SS-750T-S1	
IMM (ton)	50-200	50-200	150-250	
Crosswise Stroke (mm)	120	120	200	
Vertical Stroke (mm)	0-650	0-650	0-750	
Wrist Angle (deg)	50-90	50-90	50-90	
Max Load (with tool) (kg)	0.5	0.5	0.5	
Min Pick-out Time (sec)	0.9	0.9	1	
Min Cycle Time (sec)	4.4	4.2	4.8	
Air Pressure (bar)	4-6	4-6	4-6	
Max Air Consumption (NL/cycle) *	13	12	13	
Weight (kg)	36	48	49	
Dimensions (mm)	A	1460	1200	1250
	B		320	
	C		820	
	D		100	
	E		430	

Notes: 1). "V" stands for vacuum device.

"M" stands for middle mold detector. (Suitable for three-plate mold.)

"R" stands for claw rotating group

"EM12" stands for EUROMAP 12 communication interface.

"EM67" stands for EUROMAP 67 communication interface.

"N" stands for non-operation side, operation side without "N"

2). Power supply requirement: 1 $\Phi$ ,100~240V, 50/60Hz.

3). " \* " Max air consumption for vacuum device 30NL/min.

We reserve the right to change specifications without prior notice.

## Shini Group

Addr: No. 23, Minhe St., Shulin Dist.,  
New Taipei, Taiwan

Tel: +886 2 2680 9119

Fax: +886 2 2680 9229

Email: [shini@shini.com](mailto:shini@shini.com)

### Factories:

- Taiwan
- Dongguan
- Pinghu
- Ningbo
- Chongqing
- Pune

2016-04-15-04 Copyrights Reserved.

[www.shini.com](http://www.shini.com)