



## High Temp. Water Heater

STM-607PW



Refer carefully to this manual before operation.

## ■ Coding Principle

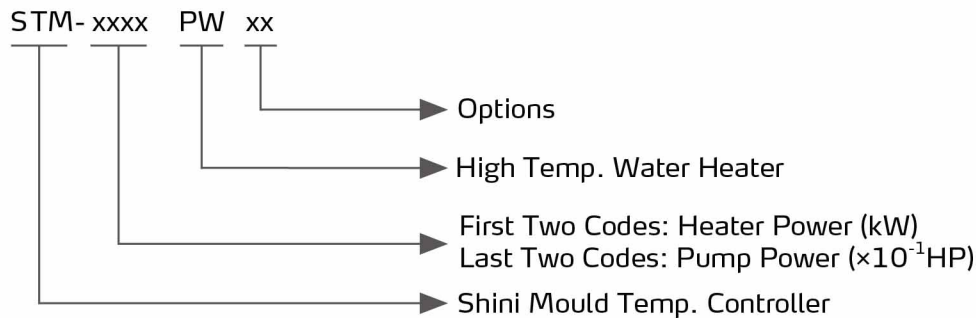

## ■ Features

- The max. working temperature can reach 180°C.
- P.I.D. multi-stage temperature control system can maintain a mould temperature with an accuracy of  $\pm 0.5^\circ\text{C}$ .
- 7-day automatic start/stop timer supports the conversion between Chinese and English, and  $^\circ\text{C}$  and  $^\circ\text{F}$ .
- When a fault occurs, this machine can automatically detect the abnormality, with failure display function.
- High voltage protection, safety pressure release, automatic water supply and exhaust function
- Adopt indirect cooling that can control the temperature more accurately, and achieve high heat exchange efficiency with the water's low viscosity property.
- Built-in magnetic pump without leakage.
- RS485 communication interface achieves centralized monitoring with the host.
- Equipped with water level probe and high-pressure plunger pump that could accurately detect the water level, and refill for high-pressure system as to avoid pipe dry burning.
- Standard equipped with the buzzer.

## ■ Options

- For models optional with magnetic filter to prolong the service life the magnetic pump, and add "MF" at the end of the model code.
- For models optional with mold temperature and mold return water temperature display, and add "TS" at the end of the model code.
- For models optional with manual air-blowing function, add "MA" at the end of the model code.

## ■ Application

STM-PW series high temp. water heaters are mainly used for mold heating and mold temperature maintaining. Besides, it is also applicable to fields with other similar demands.

Compared with the STM-W water heater, this series is able to meet wider production demands under higher heating temperature (180°C) condition. Besides, there are many options and accessories for this series of machine that can meet different production demands.

# STM-PW Series

## Working Principle

High-temp. water from the mold turns back to pump inlet through the pipeline and is sent to the heater by pump pressurizing, then it gets into the mold after heating by pipe heater, and so on. During the process, if probe detects the water level drops to the set value, the machine will start plunger pump to refill the water for 30 secs., and it will shut down to alarm if the water is still at low level. If the high-temp. water is too high, the system will start the cooling solenoid valve, and the cooling water will enter the double-tube structure to cool down the high temp. water, so that it can maintain constant water temperature. If the water temp. is still high and gets to the set EGO temperature, the system will sound alarm and stop. When system pressure is higher than the high-voltage switch set value, the machine will automatically release the pressure. If the pressure continues to rise to the safety valve set value, the mechanical safety valve opens to release the pressure of the system.

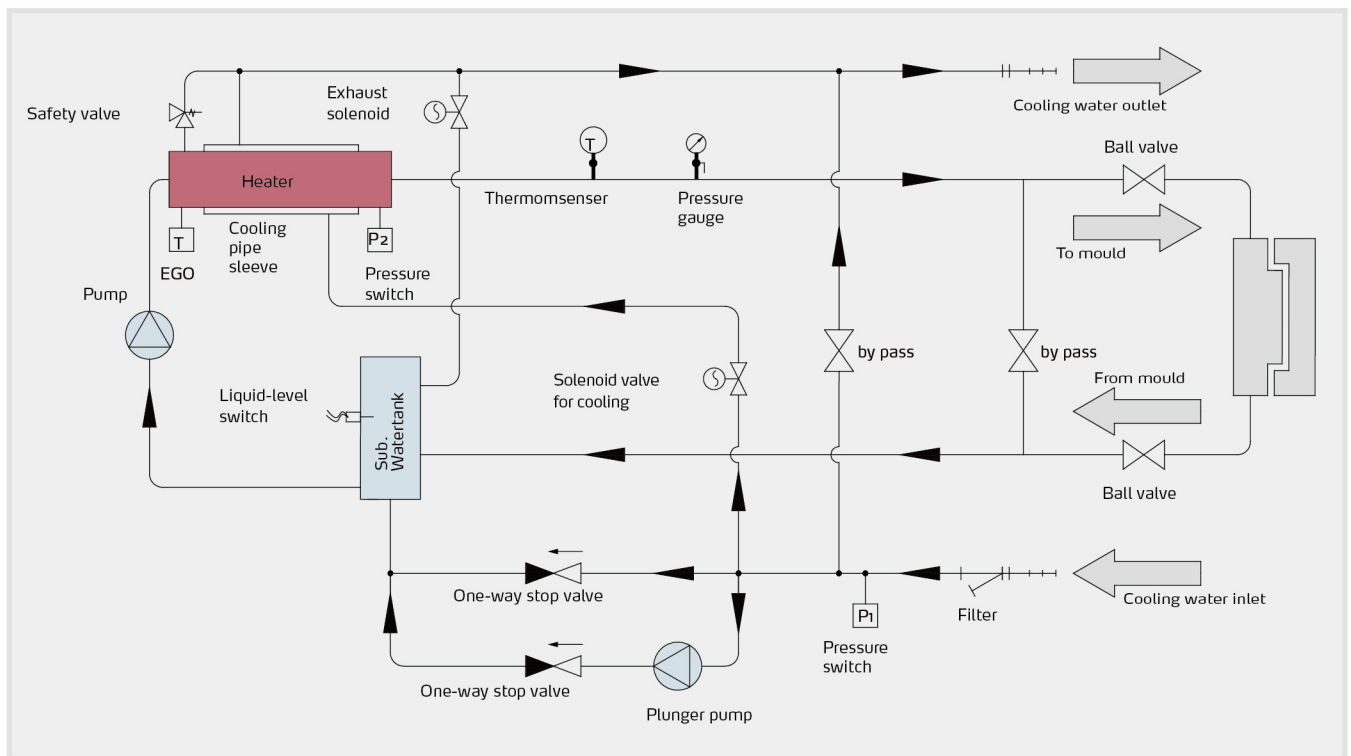

STM-PW System flow chart



## ■ Specifications

Model		STM-607PW	STM-607PW-D	STM-1220PW	STM-1220PW-D	STM-2440PW
Max.Temp.		180 <sup>0</sup> C/356 <sup>0</sup> F				
Pipe Heater(kW)		6	6×2	12	12×2	24
Pump Power(kW) (50/60Hz)		0.6/0.69	0.6×2/0.69×2	1.0/1.2	1.05×2/1.2×2	2.9/3.4
Max. pump Flow (50/60Hz)	L/min	25.5/28	25.5/28	50/60	50/60	100/120
	gal/min	6.7/7.4	6.7/7.4	13.2/15.8	13.2/15.8	26.4/31.7
Max. pump Pressure(bar)(50/60Hz)		4.8/6.3	4.8/6.3	5.8/7.6	5.8/7.6	8/10.5
Heating Tank Number		1	2	1	2	2
Heating Tank Capacity	L	3.4	3.4	3.4	3.2×2	6.2
	gal	0.9	0.9	0.9	0.85×2	1.64
Sub. water tank Capacity	L	1.4	1.4	1.4	1.4×2	1.8
	gal	0.37	0.37	0.37	0.37×2	0.48
CoolingMethod		Indirect				
Inlet/Outlet (inch)		3/4 / 3/4	3/4 / 3/4	3/4 / 3/4	3/4 / 3/4	1 / 1
Dimensions (H×W×D)	mm	690×320×910	750×620×990	690×320×990	750×620×990	950×450×1050
	inch	27.2×12.5×35.8	29.5×24.4×39	27.2×12.5×39	29.5×24.4×39	37.4×17.7×41.3
Weight	kg	80	185	95	190	140
	lb	176	408	209	419	309

- Notes: 1) To ensure stable water temperature, cooling water pressure should not be less than 2kgf/cm<sup>2</sup>, but also no more than 5kgf/cm<sup>2</sup>.  
 2) Pump testing standard: Power of 50/60Hz, purified water at 20°C/68°F. (There is ±10% tolerance for either max. flowrate or max. pressure).  
 3) Power supply: 3Φ, 230/400/460/575VAC, 50/60Hz.

We reserve the right to change specifications without prior notice.