



Dual-purpose Water/Oil Heater

STM-607W



Refer carefully to this manual before operation.

STM-WF Series

■ Coding Principle

STM- xxxx W/O

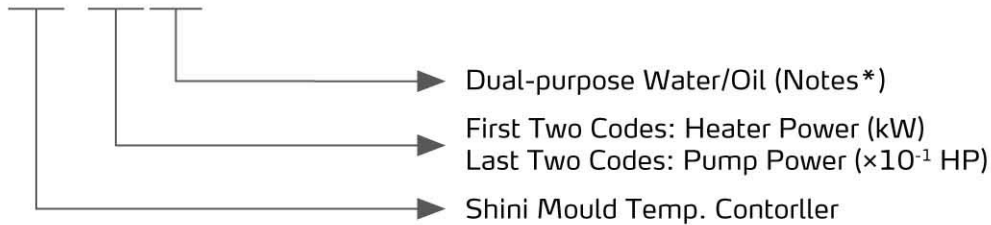

Notes*: CE= CE Conformity

■ Features

Standard configuration

- Controller adopts 3.2 " LCD for easy operation.
- Equipped with the design of 7-day automatic start/stop timer. LCD screen can be converted between Chinese and English. The unit of temperature can be converted between °F and °C.
- P.I.D. multi-stage temperature control system can maintain a mould temperature with an accuracy of $\pm 0.5^{\circ}\text{C}$.
- Adopts high efficiency, vertical dual-purpose of water/oil high pressure pump to ensure stable performance and great pressure.
- Multiple safety devices including power reverse phase protection, pump overload protection, overheat protection and low level protection that can automatically detect abnormal performance and indicate this via visible alarm.
- Adopts water or oil as heating medium, the maximum temperature can reach: water is 95°C and oil is 160°C .
- Equipped with pump reversion evacuation, automatic water supplying and negative pressure operation.

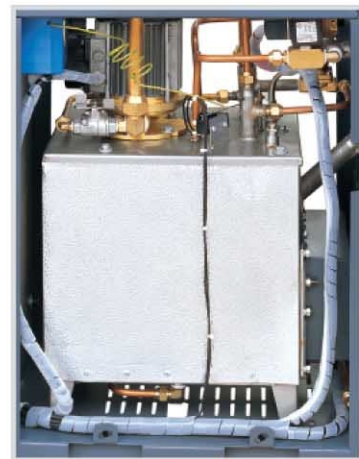

Inner Structure

Accessory option

- Water manifolds, teflon hose and transfer oil are optional.
- RS485 communication function is optional. Display of mould temperature and mould return water temperature is optional.



Control Panel

■ Application

STM-W/O series of dual-purpose heaters are mainly used to heat up the mould and maintain its temperature, also they can be also used in similar applications. High temperature water or oil return from the mould is cooled by indirect cooling and then sent to the pipe heaters via high pressure pump for heating to a constant temperature. This unique design allows user to choose between water and oil as heat transfer medium. With our optimized design, the newly applied temperature controller can maintain an accuracy of $\pm 0.5^{\circ}\text{C}$.

Working Principle

High temperature water returns to the machine and then be pressured by pump to the heaters. After being heated, water will be forced to mould and continue the circle. In the process, if the temperature is too high, the system will activate the solenoid valve to let cooling water lower the temperature directly till the water temperature is down to the system requirement. If the temperature keep rising and reach the set point of EGO, the system will alarm and stop operation. The system will have low pressure alarm and stop working if cooling water pressure doesn't reach the set point.

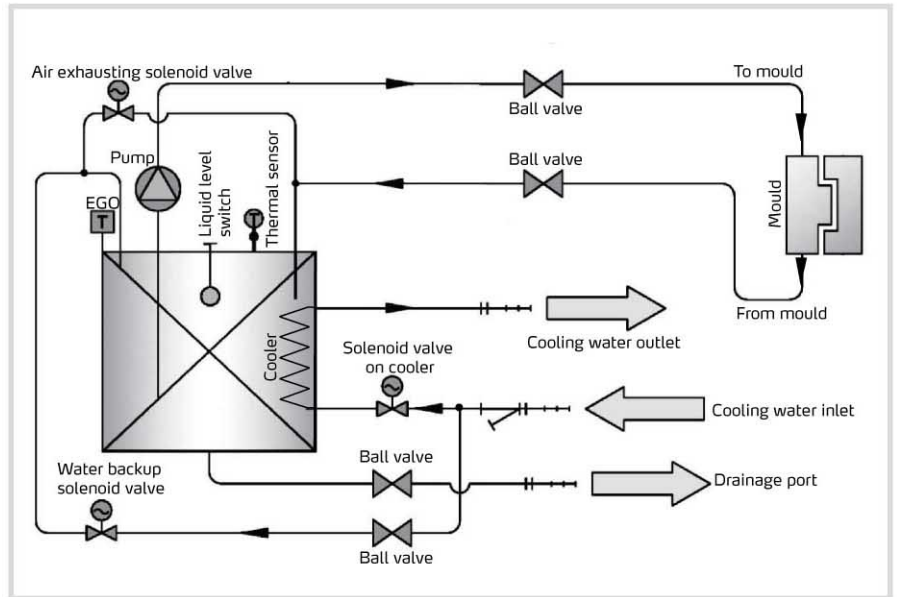

System Flow (Indirect Cooling)

Specifications

| Model | Max. Temp. | Heater (kW) | Pump (kW) | Max. Pump Flow (L/min) | Pump Pressure (bar) | Heating Tank | Heating Tank Volume (L) | Cooling Method | Mould Coupling* (inch) | Inlet/Outlet (inch) | Dimensions (mm) (H x W x D) | Weight (kg) |
|--------------|---------------------|---------------|-----------|------------------------|---------------------|--------------|-------------------------|----------------|------------------------|---------------------|-----------------------------|-------------|
| STM-607-W/O | | 6 | 0.55 | 55 | 3.4 | 1 | 12 | Indirect | 3/8 (2x2) | 3/4 / 3/4 | 820x312x725 | 75 |
| STM-907-W/O | W: 95°C O: 160°C | W: 9 O: 6 | 0.55 | 55 | 3.4 | 1 | 16 | | 3/8 (2x2) | 3/4 / 3/4 | 815x360x860 | 84 |
| STM-1207-W/O | | W: 12 O: 6 | 0.55 | 55 | 3.4 | 1 | 16 | | 3/8 (2x2) | 3/4 / 3/4 | 815x360x860 | 85 |

Notes: 1) Pump testing conditions: Power of 50 / 60Hz, purified water in 20°C. (There is ± 10% tolerance for either max. flowrate or max. pressure).
2) "*" stands for options.
3) Power supply: 3Φ, 230/400/460/575VAC, 50/60 Hz.

We reserve the right to change specifications without prior notice.

Pump Performance

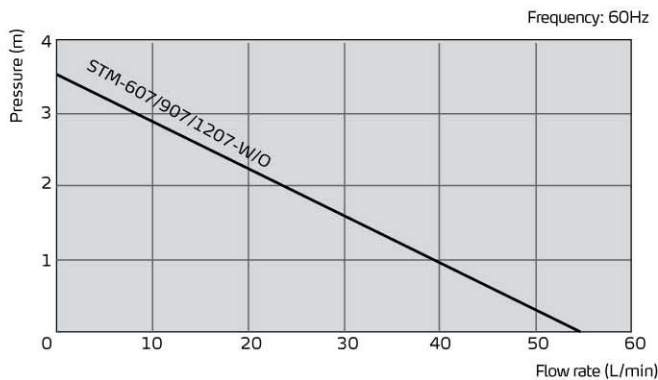

Reference formula of Mould Controllers model selection

$$\text{Heater Power (kW)} = \text{mould weight (kg)} \times \text{mould specific heat (kcal/kg}^\circ\text{C)} \times \text{temperature difference between mould and environment (}^\circ\text{C)} \times \text{safety coefficient} / \text{heating duration} / 860$$

Notes: safety coefficient range 1.3~1.5.

$$\text{Flow Rate (L/min)} = \text{heater power (kW)} \times 860 / [\text{heating medium specific (kcal/kg}^\circ\text{C)} \times \text{heating medium density (kg/L)} \times \text{in/outlet temperature difference (}^\circ\text{C)} \times \text{time (60)}]$$

Notes: Water specific heat =1kcal/kg°C
Heating medium oil specific heat =0.49kcal/kg°C
Water density =1kg/L
Heating medium oil density =0.842kg/L

Shini Group

Addr.: No. 23, Minhe St., Shulin Dist.,
New Taipei, Taiwan

Tel: +886 2 2680 9119

Fax: +886 2 2680 9229

Email: shini@shini.com

Factories:

- Taiwan
- Dongguan
- Pinghu
- Ningbo
- Mumbai

2013-01-04-04 Copyrights Reserved.

www.shini.com