



Water-cooled Central Water Chiller

SICC-450WD-R3



Refer carefully to this manual before operation.

SICC-W Series

■ Coding Principle

SICC - xxxWx - R3

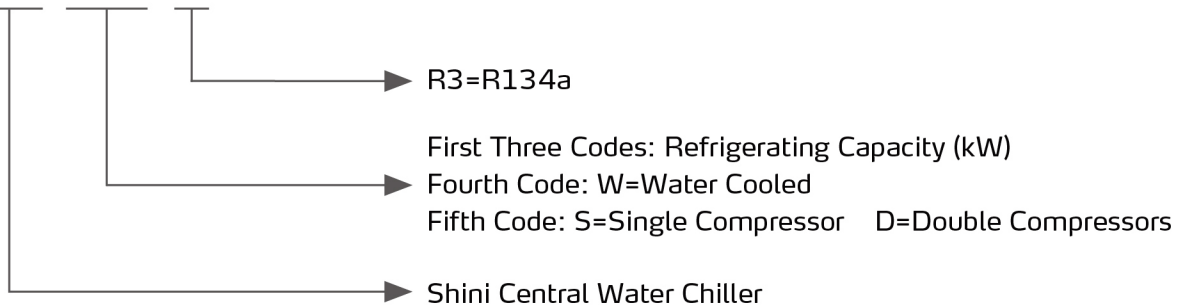

■ Features

- Brand semi-close double-screw compressor and long service-life of bearing ensure long time operation, and it is equipped with high-efficient motor that gives compressor high efficiency.
- Step-less load compressor can achieve refrigerating output continuously kept within 25%-100% to reach stable energy output control.
- The condenser and evaporator both can meet the requirement of national standard, with high-efficient heat transfer effect, convenient service and maintenance.
- Standard equipped RS485 communication function that can achieve machine unit's real-time control and monitor.
- Equipped with programmable logical controller to control via panel for convenient adjustment;
- The fault check function and fault recording function can analyze the causes for improvement.
- Standard equipped with high and low pressure switch, fusible plug, overload protector, coil overheat protector, exhaust air overheat protection, cooling water overheat and large temperature deviation protection.

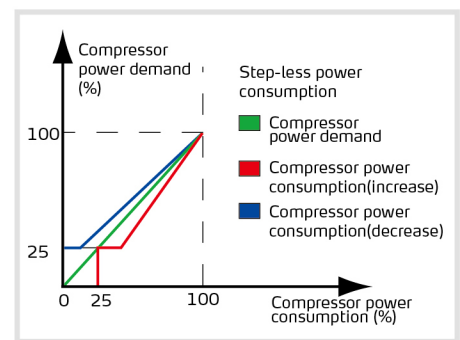

Step-less loading capacity

■ Application

It is used for mould's cooling to reduce product's molding cycle, and it's applicable to cooling devices to ensure the temperature maintained under normal value, or other industrial areas need cooling.

■ Working Principle

The SICC-W water-cooled central water chiller is mainly made up of four components which are compressor, condenser, thermostatic expansion valve and evaporator. It uses single stage vapor compression refrigeration system, and takes advantage of the mechanism of transformation between air and liquid status for absorbing and releasing heat by using of refrigerant to achieve the effectiveness of refrigeration.

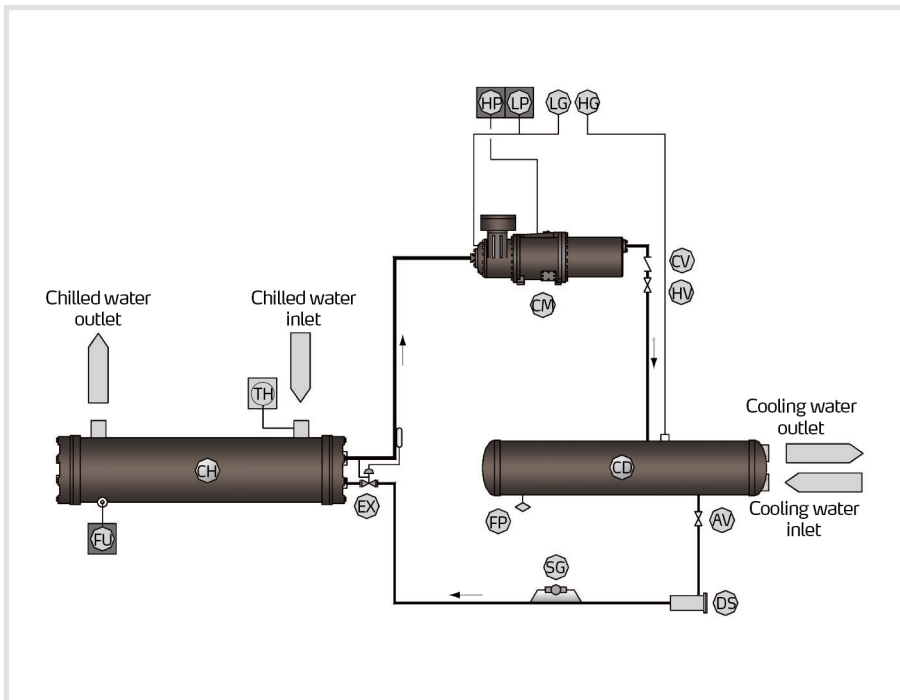

One Compressor

Sign	Name	Amount	Remark
CM	Compressor	1	
CD	Condenser	1	
CH	Evaporator	1	
EX	Expansion valve	1	
FP	Fusible plug	1	
AV	Angle valve	1	
DS	Drier filter	1	
SG	Refrigerant indicator	1	
CV	Contrary stop value	1	
HV	High pressure valve	1	
HG	High pressure gauge	1	
LG	low pressure gauge	1	
HP	High pressure switch	1	
LP	Low pressure switch	1	
TH	Thermo switch	1	
FU	Anti-freezing switch	1	

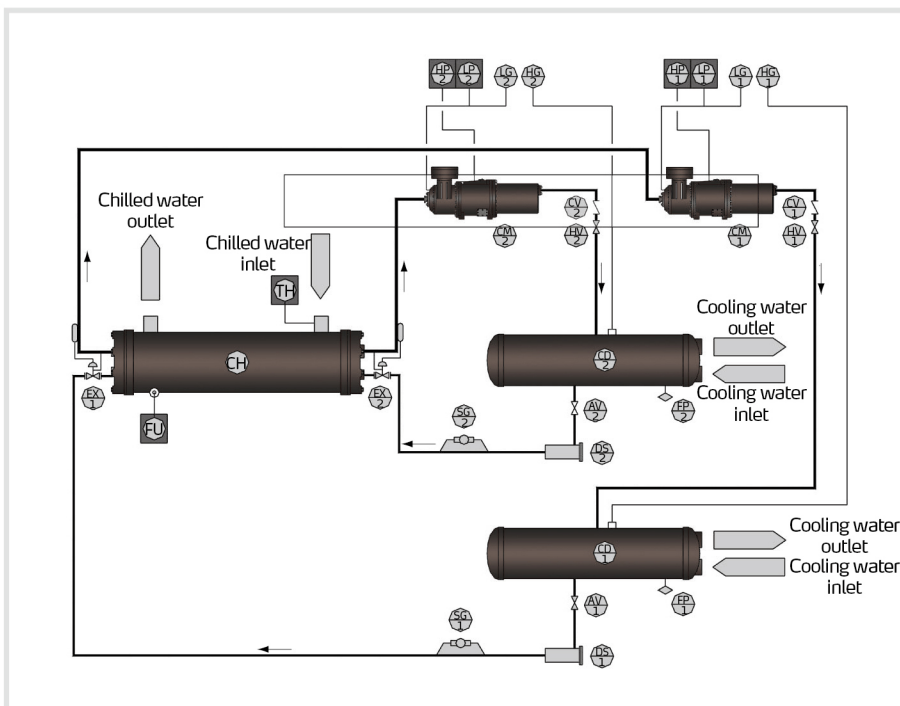

Two Compressors

Sign	Name	Amount	Remark
CM1-2	Compressor	2	
CD1-2	Condenser	2	
CH	Evaporator	1	
EX1-2	Expansion valve	2	
FP1-2	Fusible plug	2	
AV1-2	Angle valve	2	
DS1-2	Drier filter	2	
SG1-2	Refrigerant indicator	2	
CV1-2	Contrary stop value	2	
HV1-2	High pressure valve	2	
HG1-2	High pressure gauge	2	
LG1-2	low pressure gauge	2	
HP1-2	High pressure switch	2	
LP1-2	Low pressure switch	2	
TH	Thermo switch	1	
FU	Anti-freezing switch	1	

SICC-W Series

■ Foundation and Installation

Selection of Installation Environment

- 1) Please select a firm and solid ground which can fully support machine when running. The ground selection has also to avoid any happens of vibration and noisy environment.
- 2) The machine should be installed in a place without any exposures from wind, rain, sunlight, or any heat source occurrence.
- 3) Ambient temperature is within 0~40°C/0~104°F, relative humidity (RH) is 75%, good ventilation and with less dust and sand.
- 4) Installation should be carried through in a place with easy access to electrical power and convenient construction.
- 5) When install, please preserve a maintenance space, as shown on the right. For the cleaning of the condenser, please reserve space of 0.8L/0.2gal on either left or right side of the machine.

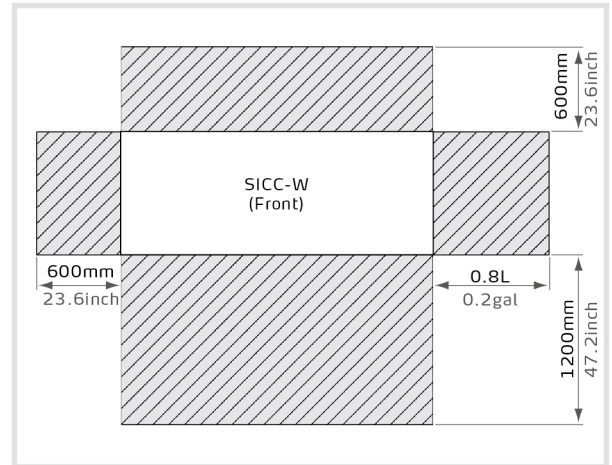

Foundation Base

- 1) The foundation of the concrete base, according to the operation weight of the machines, will put on steel bars, diameter above 9.5mm/ $3/8$ " , and are clustered together on the upper and lower layer of the base, interspaced about 100mm/4" .
- 2) When making concrete floor to be foundation, it is necessary to rough the surface. Clean the floor before installation.
- 3) The concrete base has to be rigid; the mixing proportion of concrete is 1: 2: 4. Put required anchor bolts into base, according to the request. Polishing and flat the surface of the base when finished.
- 4) Put the machine on the base when it is fully dried out and rigid.
- 5) It has to be a well drainage works around the base to prevent water remaining.

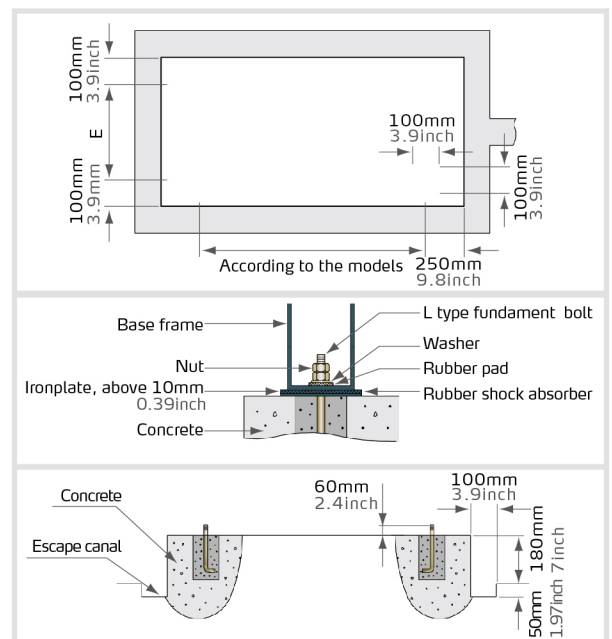

Outline Drawings

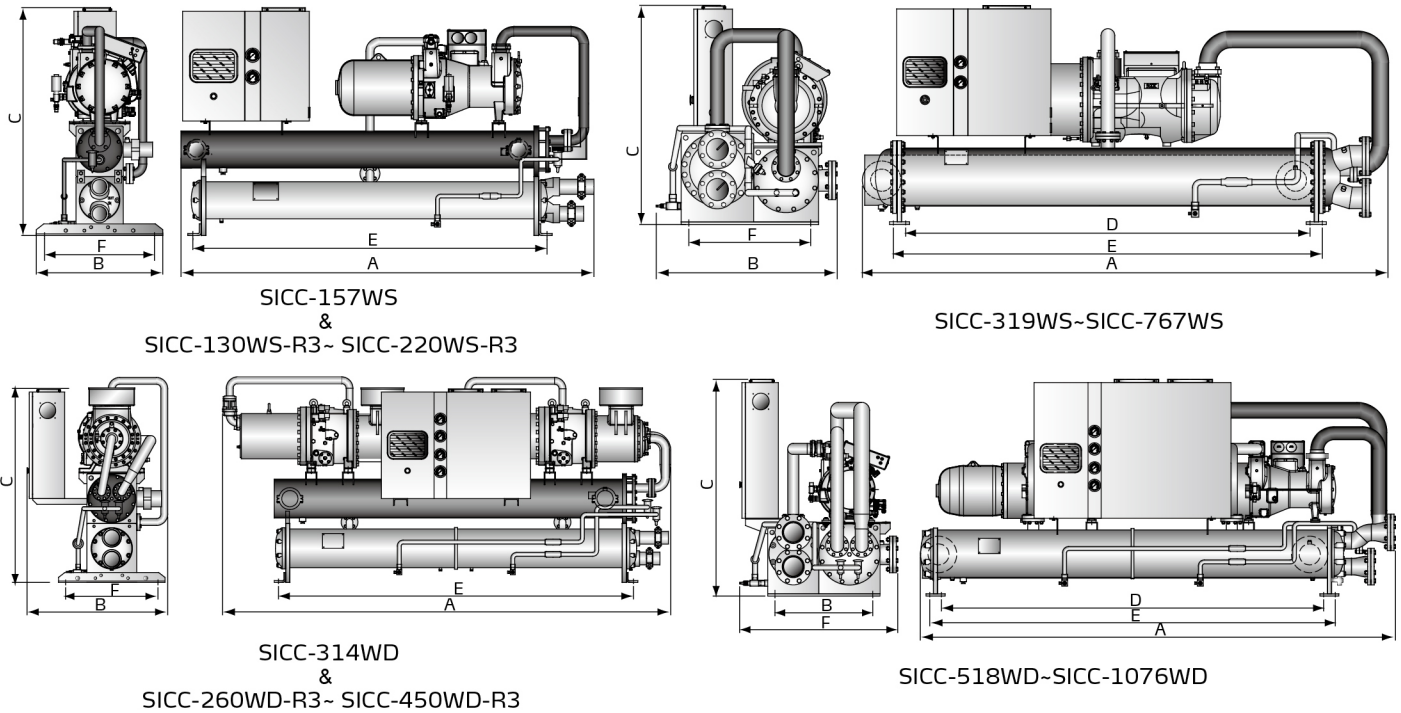

Specifications (Single Compressor R22)

Item		Model SICC-	157WS	319WS	413WS	538WS	611WS	767WS
Refrigeration Capacity	kW ⁽¹⁾		157	319	413	538	611	767
	kW ⁽²⁾		128	251	330	430	488	610
Power Source	—		3Φ 380V 50Hz					
Power Consumption	kW		35.4	68	100.3	120.9	125.9	156.7
Operation Current	A		63	122	179	216	225	280
Start-up Current	A		269	516	579	757	586	805
Power Adjustment	—		Capacity level 4 control					
Refrigeration Oil	Filling Quantity	L	11	17	17	21	21	25
	Type	—	KL320SH					
Refrigerant Filling Quantity	kg		26	46	61	76	91	111
Evaporator	Type	—	U type tube-in-shell style			Tube-in-shell style		
	Process Flow	m ³ /hr	27.0	54.9	71.0	92.5	105.0	131.9
	Pressure Loss	kPa	48	54	63	63	66	80
	Pipe Coupler		Φ3"Clamp	Φ4"Clamp	Φ4"Clamp	DN125	DN150	DN150
Condenser	Type	—	Tube-in-shell style					
	Cooling Flow	m ³ /hr	35.1	71.3	92.3	120.3	136.6	171.5
	Pressure Loss	kPa	20	30	45	45	45	58
	Pipe Coupler		Φ3"Clamp	Φ4"Clamp	Φ4"Clamp	DN125	DN150	DN150
Unit Dimensions	A	mm	2600	3050	3350	3450	3400	3800
	B	mm	750	1150	1250	1250	1350	1400
	C	mm	1500	1370	1450	1500	1650	1700
Installing Dimensions	D	mm	—	2390	2620	2620	2620	2920
	E	mm	2100	2550	2780	2780	2780	3080
	F	mm	650	600	670	790	870	920
Net Weight	kg		1220	1770	1900	2350	2600	3130
Operating Weight	kg		1370	1970	2150	2650	2900	3480
Measures Exchange			1 kW = 860 kcal/hr		1 RT = 3,024 kcal/hr		10,000 Btu/hr = 2,520 kcal/hr	

SICC-W Series

Specifications (Single Compressor R22)

Model		SICC-314WD	SICC-518WD	SICC-638WD	SICC-706WD	SICC-826WD	SICC-1076WD	
Refrigeration Capacity	kW ¹⁾	314	518	638	706	826	1076	
	kW ²⁾	256	408	502	578	660	860	
Power Source	—	3Φ 380V 50Hz						
Power Consumption	kW	70.8	119.2	136.0	162.6	200.6	241.8	
Power Consumption	A	126	213	243	291	359	432	
Operation Current	A	332	530	638	707	758	973	
Power Adjustment	—	Capacity level 8 control						
Refrigeration Oil	Refrigerant Filling Quantity	L	22	26	34	34	42	
	Type	—	KL320SH					
Refrigerant Filling Quantity	kg	51	71	91	111	121	151	
Evaporator	Type	—	U type tube-in-shell style			Tube-in-shell style		
		m ³ /hr	54.0	89.1	109.8	121.4	142.1	185.0
	Pressure Loss	kPa	60	63	66	66	66	80
	Pipe Coupler		Φ4"Clamp	DN125	DN150	DN150	DN150	DN200
Condenser	Type	—	Tube-in-shell style					
	Cooling Flow	m ³ /hr	70.2	115.8	142.7	157.9	184.7	240.6
	Pressure Loss	M	40	40	57	57	57	64
	Pipe Outlet		Φ4"Clamp	DN125	DN150	DN150	DN150	DN200
Unit Dimensions	A	mm	3180	3300	3900	3950	4000	4300
	B	mm	1050	1150	1300	1350	1450	1500
	C	mm	1700	1550	1600	1650	1650	1700
Installing Dimensions	D	mm	—	2620	2920	2920	2920	3190
	E	mm	2700	2780	3080	3080	3080	3350
	F	mm	650	670	870	920	980	1030
Net Weight	kg	2010	2610	3300	3700	3880	4350	
Operating Weight	kg	2210	2910	3600	4200	4380	4900	
Measures Exchange		1 kW = 860 kcal/hr		1 RT = 3,024 kcal/hr	10,000 Btu/hr = 2,520 kcal/hr			

- Notes: 1) Refrigeration capacity 1 is based on the flow of 0.172m³/(h.kW), the chilled water outlet temperature of 15°C/59°F and the environment temperature of 30°C/86°F.
- 2) Refrigeration capacity 2 is based on the flow of 0.172m³/(h.kW), the chilled water outlet temperature of 7°C/44.6°F and the environment temperature of 30°C/86°F.
- 3) Machine operation conditions: outlet chilling water temperature is at 8-25°C, inlet chilling water temperature is at 19-33°C. For special requirements, the machine can be customized.
- 4) The noise level is tested at 1m in front of and 1.5m above the machine.
- 5) As per application needs, stepless compressor output capacity adjusting function can be optionally available.



■ Specifications (Single Compressor R134a)

Model SICC-		130WS-R3	188WS-R3	220WS-R3	260WD-R3	380WD-R3	450WD-R3	
Refrigeration Capacity	kW ¹⁾	130	188	220	260	380	450	
	kW ²⁾	104	150	176	208	300	351	
Power Source	—	3Φ 400V 50Hz						
Power Consumption	kW	24	35.8	40.9	48	71.6	81.8	
Operation Current	A	41.5	60	69	83	120	138	
Start-up Current	A	310	480	600	351.5	540	669	
Power Adjustment	—	Step-less loading capacity control						
Refrigeration Oil	Filling Quantity	L	7	14	16	14	28	32
	Type	—	HBR-B08			HBR-B08		
Refrigerant Filling Quantity	kg	22	26	32	44	52	64	
Evaporator	Type	—	Tube-in-shell style					
	Process Flow	m ³ /hr	22	32	37.5	44	64	75
	Pressure Loss	kPa	46	50	52	58	63	63
	Pipe Coupler		Φ3"Clamp	Φ3"Clamp	Φ3"Clamp	Φ4"Clamp	Φ5"Clamp	Φ5"Clamp
Condenser	Type		Tube-in-shell style					
	Cooling Flow	m ³ /hr	26.5	38.5	45	53	77	90
	Pressure Loss	kPa	20	20	30	40	40	60
	Pipe Outlet		2.5"PT Female	3.0"PT Female	3.0"PT Female	2.5"PT Female	3.0"PT Female	3.0"PT Female
Unit Dimensions	A	mm	2490	2650	2780	2850	3110	3250
	B	mm	750	850	850	1075	1125	1125
	C	mm	1525	1655	1670	1570	1750	1750
Installing Dimensions	D	mm	—	—	—	—	—	—
	E	mm	1100	1266	1327	1260	1467	1467
	F	mm	540	640	640	798	878	878
Net Weight	kg	940	1200	1260	1860	2340	2530	
Operating Weight	kg	1040	1300	1360	2060	2590	2800	
Measures Exchange		1 kW = 860 kcal/hr		1 RT = 3,024 kcal/hr	10,000 Btu/hr = 2,520 kcal/hr			

- Notes: 1) Refrigeration capacity 1 is based on the flow of 0.172m³/(h.kW), the chilled water outlet temperature of 15°C/59°F and the environment temperature of 30°C/86°F.
- 2) Refrigeration capacity 2 is based on the flow of 0.172m³/(h.kW), the chilled water outlet temperature of 7°C/44.6°F and the environment temperature of 30°C/86°F.
- 3) Machine operation conditions: outlet chilling water temperature is at 8~25°C, inlet chilling water temperature is at 19~33°C. For special requirements, the machine can be customized.
- 4) The noise level is tested at 1m in front of and 1.5m above the machine.
- 5) As per application needs, stepless compressor output capacity adjusting function can be optionally available.