



CFC-free Refrigerant Air-cooled Central Water Chiller

SICC-90A-R2



Refer carefully to this manual before operation.

SICC-A-R2 Series

■ Coding Principle

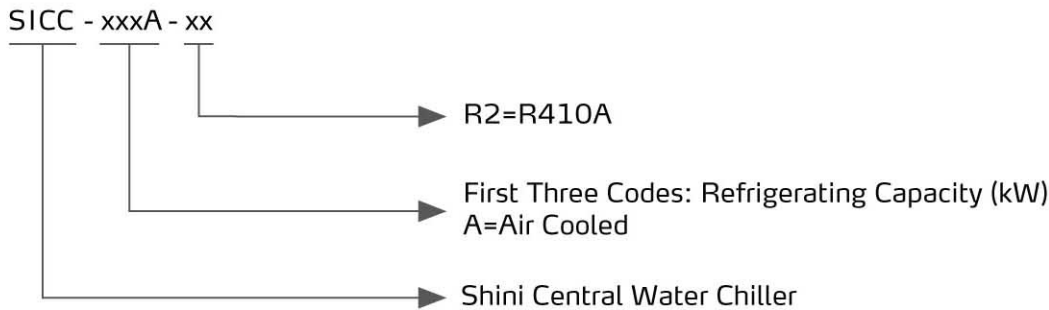

■ Features

Standard configuration

- Modularized design makes it easier to combine module units 1 to 15. Cooling capacity can be enlarged by increasing the number of modules or choose appropriate modules to connect to existing system.
- The water route of the modules can be linked via linking one module to the inlet/outlet water tube. No need to install the inlet/outlet water tube for each module alone. The soft rubber tube is used to connect the modules, thus it is very convenient to construct.
- Adopts imported components like scroll compressor, expansion valve which ensure stable performance. The whole unit will not stop due to one module failure.
- When the whole unit is running, the microcomputer will automatically adjust the performance of each module or open/shut respective module unit according to system load. The module unit adopts double compressors and its power adjustable range is enlarged after combination to save up power whenever possible.
- Wired control system enables the main unit and its controller to be separated from each other.
- Protection grade: IP54

Accessory option

- Optional RS485 communication realizes remote monitoring and network function.

■ Application

SICC-A series are applicable for cooling molds to reduce products molding cycle, also they are available in the cooling of equipments in order to maintain normal temperature. Besides, they are suitable in other industries with the need of cooling.

SICC-A-R2 Series

Working Principle

Cooling circulation: the high temp. high pressure air from compressor's high pressure spraying outlet comes into fin type air side heat exchanger, which works as a condenser to cool down the air into liquid. Then it comes into expansion valve after filtration. There, after a pressure downfall, it comes into shell and tube type evaporator. The low temp. low pressure and saturated refrigerant absorbs the heat from cooling water so to low down its temp.. The state of the shell and tube type evaporator's refrigerant outlet are low temp.. Low pressure air then comes to air and liquid separator to be separated. Therefore, the air comes to compressor's low pressure air suction inlet to get compressed. The high pressure spraying outlet (compressor)→condenser (air side heat exchanger)→filter expansion valve→evaporator (water side heat exchanger)→air and liquid separator→the low pressure air suction inlet.

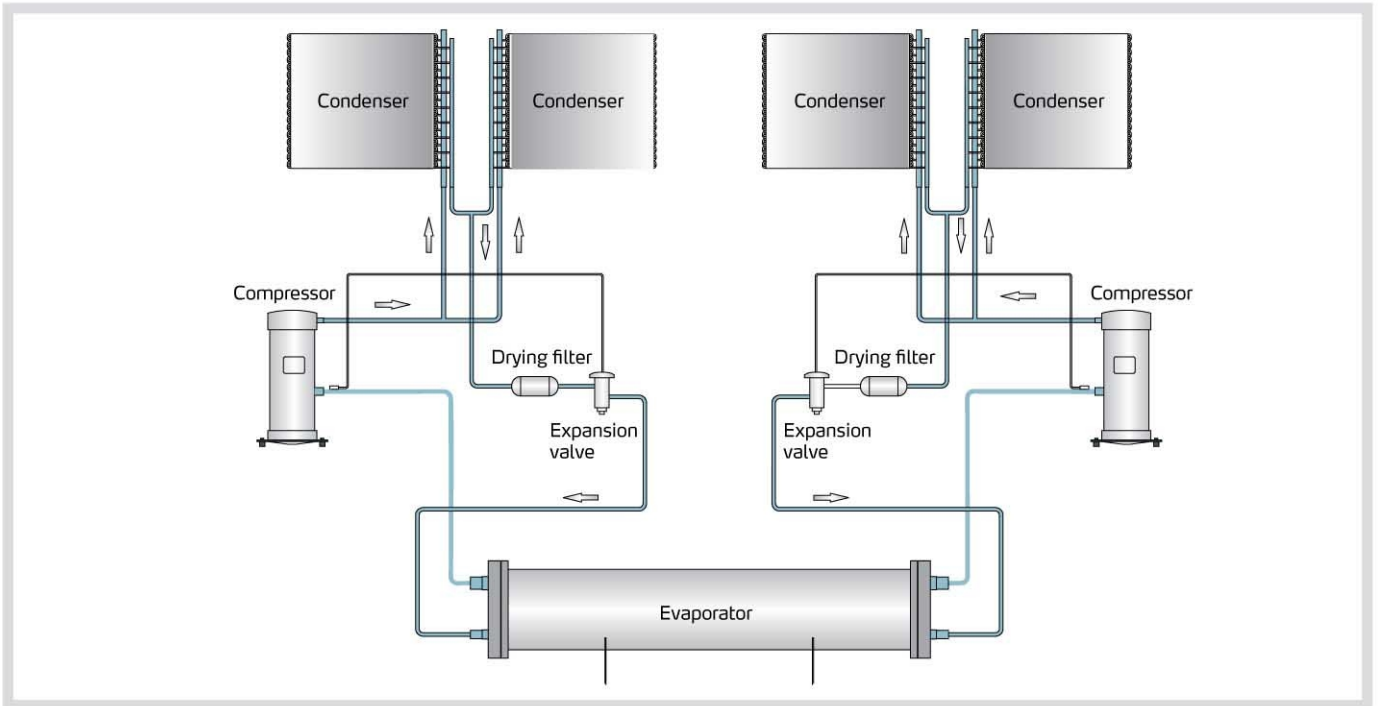

Foundation and Installation

Select Installation Site

- 1) No heat source exists nearby to avoid efficiency reduction due to hot air absorbing.
- 2) No impact imposed by high temperature, vapor or oil stain.
- 3) Avoid being spattering by vapor when choosing installation site near cooling water tower so to avoid any short circuit or creepage.
- 4) Proper ventilation without hindrance for air inhaled or exhaled.
- 5) No existence of inflammable substance.
- 6) When using concrete bearing platform if necessary.
- 7) Set apart some service space. Space recommended as shown in the picture on the right.

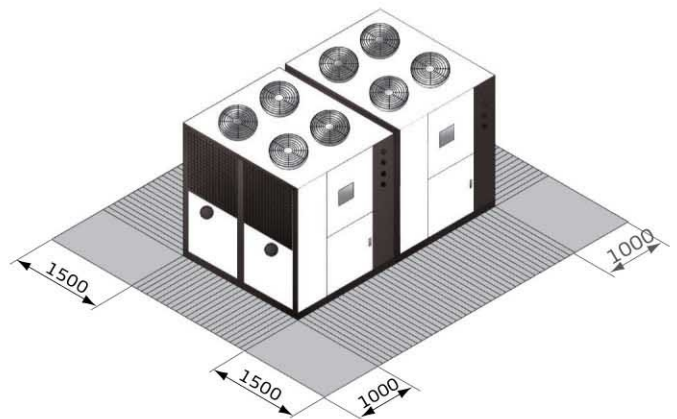

Installation Spece (Unit: mm)

Installation

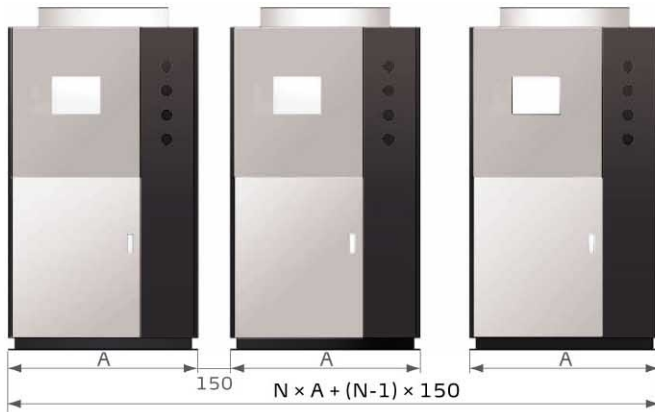

Type	Module Model	Model Dimension (A)	Combination Dimension
Module Unit	SICC-60A-R2	975	$N \times A + (N-1) \times 150$
	SICC-90A-R2	1170	
	SICC-120A-R2	1825	

Notes: Combination of modules unit as shown in left figure. Unit: mm.

Bearing Platform

- 1) The unit should be installed on concrete or steel structure bearing platform that is firm and the surface of the bearing platform should be smooth and flat. The platform should hold the whole unit, if the intensity is not strong enough; it is easy to cause vibration or noise.
- 2) The surface of the concrete base platform normally has been plastered as horizontal ornament, with waterproof treatment. The surrounding of it should have drainage sink placed, and the slope angle should be bigger than 0.5%, and the slope should lead to drainage outlet.
- 3) In order to maintain quiet operation and prevent the vibration and noise transmission from interfering the under floors, the absorber should be laid between the unit base and base platform. Please maintain horizontal when install the unit and mount anti-vibration pad when it is necessary.
- 4) In order to keep connection pipe from being twisted to crack by earthquake, typhoon, or by long time running caused movement. The fixation should be taken into consideration, refer to following examples for platform installation and fixation.

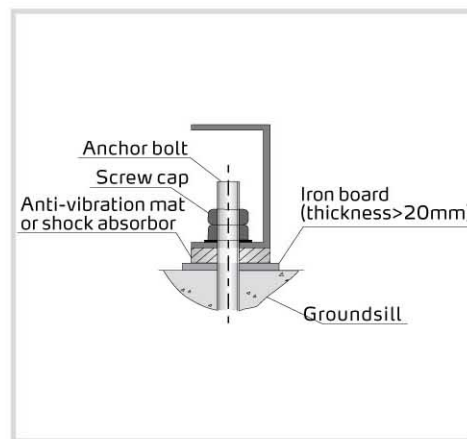
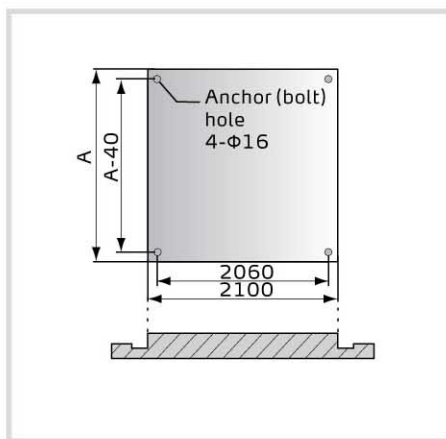

Bearing Platform Installation

SICC-A-R2 Series

Outline Drawings

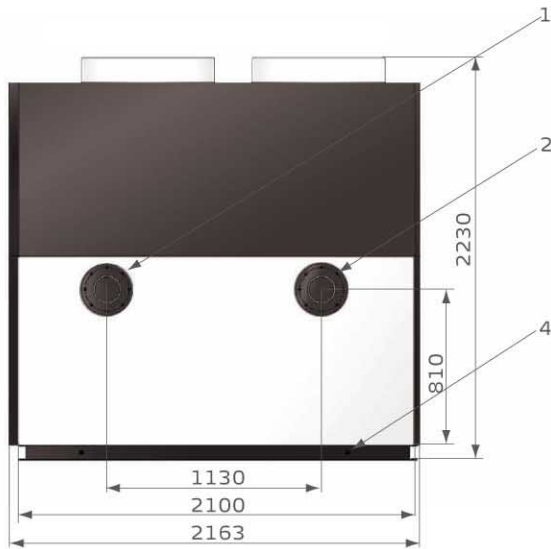

SICC-60A-R2

1. 5 inch Chilled water outlet
2. 5 inch Chilled water inlet
3. $\Phi 16$ Bearing hole
4. M16 Stationary ring bolt

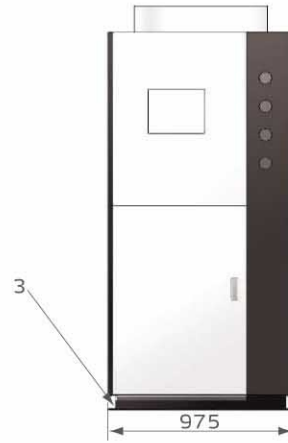

Flange

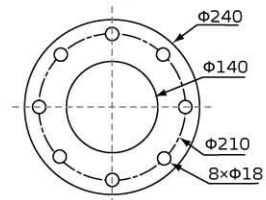

1. 5 inch Chilled water outlet
2. 5 inch Chilled water inlet
3. $\Phi 16$ Bearing hole
4. M16 Stationary ring bolt

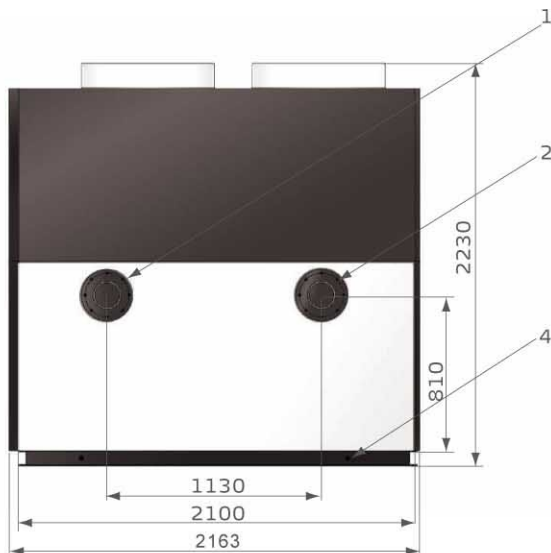

SICC-90A-R2

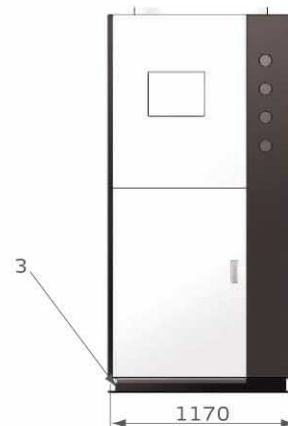

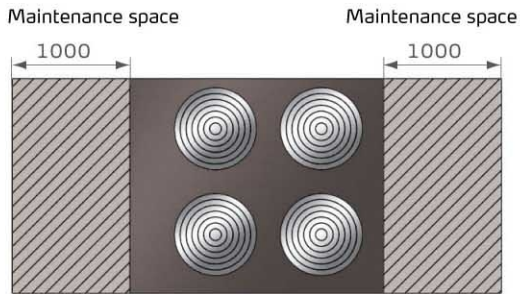

1. 5 inch Chilled water outlet
2. 5 inch Chilled water inlet
3. $\Phi 16$ Bearing hole
4. M16 Stationary ring bolt

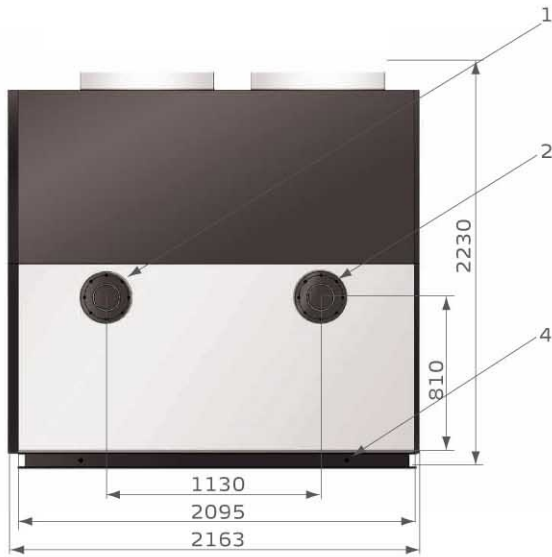

SICC-120A-R2

Module combination

Type	Model	Grouping	Compressor Power (kW)
Module Model	SICC-60A-R2	60A	17.2
	SICC-90A-R2	90A	25
	SICC-120A-R2	120A	34
Module Unit	SICC-150A-R2	60A + 90A	42.2
	SICC-180A-R2	2 × 90A	50
	SICC-210A-R2	90A + 120A	59
	SICC-240A-R2	2 × 120A	68
	SICC-270A-R2	3 × 90A	75
	SICC-300A-R2	2 × 90A + 120A	84
	SICC-330A-R2	3 × 90A + 60A	92.2
	SICC-360A-R2	3 × 120A	102

Type	Model	Grouping	Compressor Power (kW)
Module Unit	SICC-420A-R2	4 × 90A + 60A	117.2
	SICC-450A-R2	5 × 90A	125
	SICC-480A-R2	4 × 120A	136
	SICC-540A-R2	6 × 90A	150
	SICC-570A-R2	4 × 120A + 90A	161
	SICC-600A-R2	5 × 120A	170
	SICC-660A-R2	5 × 120A + 60A	187.2
	SICC-720A-R2	6 × 120A	204
	SICC-780A-R2	6 × 120A + 60A	221.2
	SICC-840A-R2	7 × 120A	238
	SICC-930A-R2	7 × 120A + 90A	263
	SICC-990A-R2	7 × 120A + 90A + 60A	280.2

We reserve the right to change specification without prior notice.

SICC-A-R2 Series

Specifications

Item		Model	SICC-60A-R2	SICC-90A-R2	SICC-120A-R2
Refrigeration Capacity	kW		60	90	120
	kcal/hr		51,600	77,400	103,200
Power			3Φ, 400VAC, 50Hz		
Total Power	kW		19	28	37
Running Current	A		35	50	65
Startup Current	A		140	175	230
Compressor	Type		Hermetic Scroll		
	Power	kW	8.6 × 2	12.5 × 2	17 × 2
	Crank Case Heater	kW	0.08 × 2	0.08 × 2	0.056 × 2
Refrigerant	Type		R410A		
	Filling Quantity	kg	15	17	26
Evaporator	Type		Tube-in-shell Evaporator		
	Cooling Flow	m ³ /hr	10.3	15.5	20.6
	Pressure Loss	kPa	27	40	53
	Pipe Coupler	inch	5	5	5
Condenser	Type		Fin Style Air-cooled Condenser		
	Blower Power	kW	1.6	2.2	3.2
	Air Quantity	m ³ /hr	26,000	39,000	52,000
Machine Dimension	Width (W)	mm	2,163	2,163	2,163
	Depth (D)	mm	975	1,170	1,825
	Height (H)	mm	2,230	2,230	2,230
Weight	Before Packing	kg	810	940	1,300
	After Packed	kg	850	1,000	1,370
Noise Level	dB(A)		78	80	85
Measures Exchange			1 kW = 860 kcal/hr	1 RT = 3,024 kcal/hr	10,000 Btu/hr = 2,520 kcal/hr

Notes: Refrigeration capacity is measured based on the flow (0.172 m³ / h·k W) and the outlet temperature (7 °C) of chilled water under the environment temperature of 35°C.

We reserve the right to change specifications without prior notice.

Shini Group

Addr.: No. 23, Minhe St., Shulin Dist.,
New Taipei, Taiwan

Tel: +886 2 2680 9119

Fax: +886 2 2680 9229

Email: shini@shini.com

Factories:

- Taiwan
- Dongguan
- Pinghu
- Ningbo
- Mumbai

2013-01-04-04 Copyrights Reserved.

www.shini.com