

## Water Flow Regulator

SFR-600



Refer carefully to this manual before operation.

## ■ Coding Principle

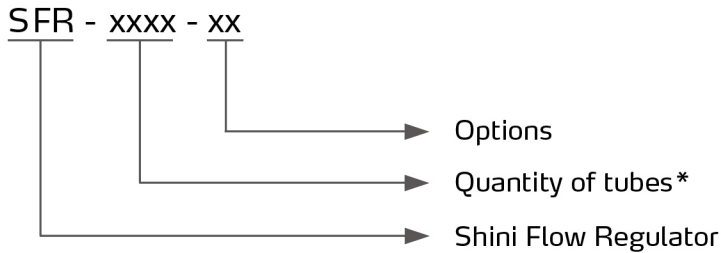

## ■ Features

- Modularized design and great expandability, which can be configured on client's demand.
- Optimal structure design, long service life.
- Flowrate is adjustable according to different demands and has temperature and flowrate display function, which can display immediately whenever there is clogging in the mould circulation loops so as to avoid producing defective products.
- Ensure the conformity of product's shrinkage by accurate and reliable mould temperature control.
- Convenient for both mounting and demounting, easy for cleaning and maintenance.
- Purely mechanical structure with no power consumption.
- Viewable flowrate display helps fast adjusting to required rate.
- Adopt precise adjusting valve, which can adjust the flowrate more accurately.
- Cleaning brush is supplied as standard for easy maintenance of flow tubes.

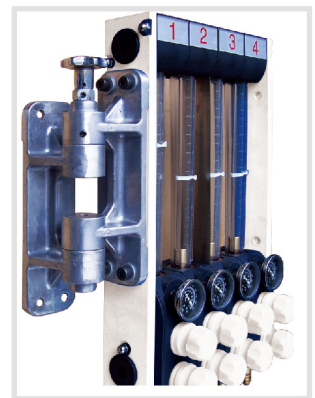

Machine Mounting Bracket (optional)

## ■ Options

- Water connection elbows with quick-release connectors , and machine mounting bracket are optional.
- Mould connector (3/8" male quick-release connector) is supplied as optional.

# SFR Series

## Application

SFR series water flow regulators are designed to work with mould heaters, water chillers and cooling towers, which can be connected to more than one mould connectors. They have the function like temperature and flowrate displays, flowrate control in order to meet the requirements of different working conditions. Modularized combination ensures convenient installation and maintenance. It is indispensable in modern plastic industry to improve its molding efficiency.

## Working Principle

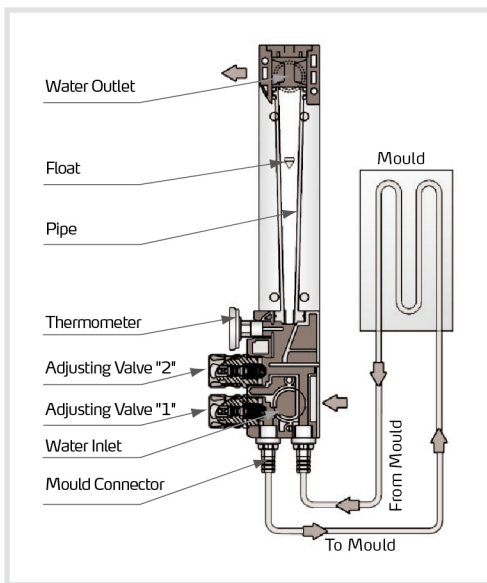

- Circulating water comes into flow regulator via water inlet.
- Then the circulating water comes into mould via the adjusting valve "1".
- After the circulating water completed its circulating in the mould, it will go back to the flow tubes via the flow regulator's return water inlet and the adjusting valve "2". Flowrate can be observed in the flow pipes.
- Circulating water returns to the mould temperature controller, water chiller or cooling tower via water outlet.
- Thermometer displays the temperature of the flow.

## Outline Drawings

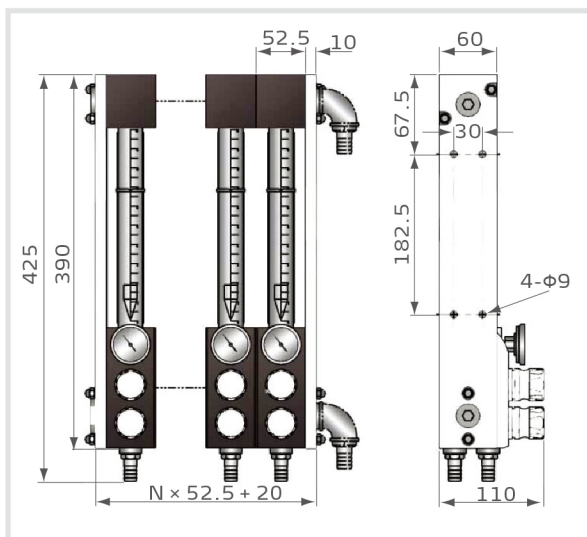

## Specifications

Model	Tube Quantity (N)
SFR-200	2
SFR-400	4
SFR-600	6
SFR-800	8
SFR-1000	10
SFR-1200	12

## ■ Technical Parameters

Max. Temperature: 100°C (212°F)

Max. Pressure: 10kgf/cm<sup>2</sup>

Flowrate Range: 0~18L/min(0~4.8gal/min) (Each pipe)

Quick-release Connector:

3/8" G Male Thread

Water Connectors:

3/4" PT Female Thread

Temp. and pressure Chart

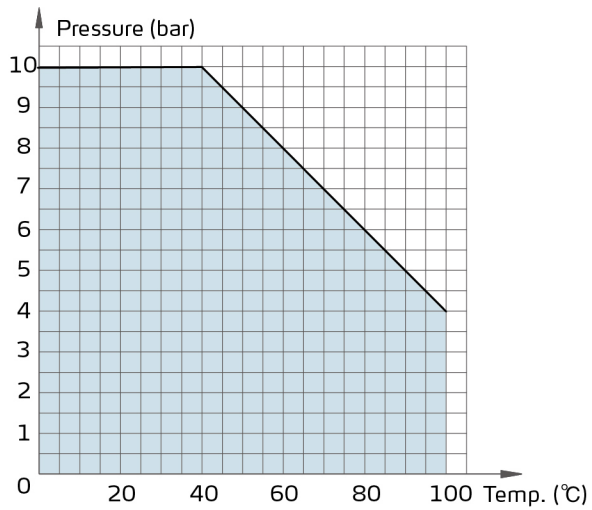

(Accuracy of this curve is within ± 5%)

Grad. and flowrate Chart

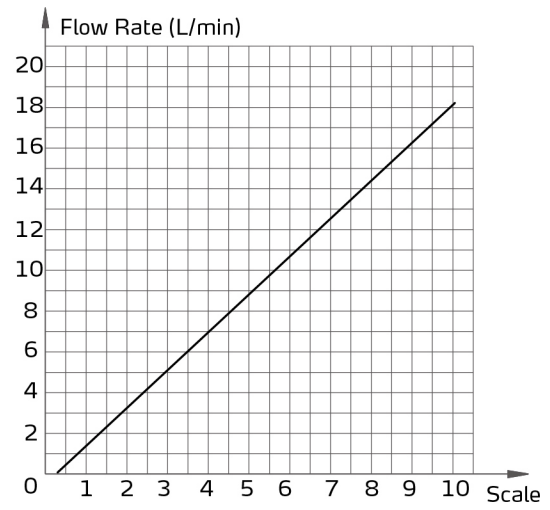

(Accuracy of this curve is within ± 0.5L/min)