



Standard Three Axes Servo Driven Robot

ST3-700-1400-S



Refer carefully to this manual before operation.

■ Coding Principle

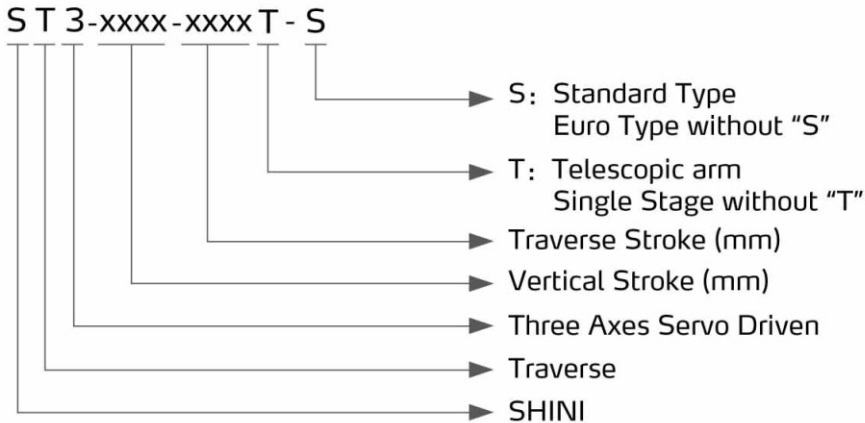

■ Features

- Precision
All linear movements are driven by heavy duty servo motors with cooperation of precise linear guide rails and high power V belts; fast, silent, and precise. Wrist mechanism employs pneumatic driven rack and pinion system, which accomplishes smooth, stabled and precise flipping motion. Vertical arm with telescopic design efficiently minimizes the cycle time and height of the robot.
- Safety
Position limit sensors and blocks effectively prevent mechanical and electrical malfunctions. Control board with short circuit function.
- Intelligence
8.0 inch high definition TFT touch screen. 3-point switch for safer robot operation. CPU modularization, the operator, main control modular and extension modular has independent CPU, improve the system's respond and keep it safety. The hardware used multi-layer PCB and multi-rank high precision electrical modular, strong anti - interference ability. Hardware protect function, each signal output with intelligent detection, avoid short-circuit, overload and high temperature. Base on the VARAN BUS technology, the system can be extended, strong adaptability and flexibility. Teach modules with stacking and matrix locate functions, support conditional judgment, loop control, signal waiting and others logic instructions.
- User Friendly
Multi-languages system and reserved auxiliary equipment slots able to support our global clients' need.



Home Page



Program Page



ST3-700-1400T-S



ST3-1400-2200MT-S



ST3-1800-2400LT-S

■ Application

The ST3-S series robot is designed for rapid and precise removal of products from injection molding machine, and place them at desired locations. Apply to 2-plate mold or hot runner system. Capable of arranging, stacking, quality checking and in mold placement. Suitable for injection molding machine with clamping force under 3600 tons.

ST3-S Series

Outline Drawings

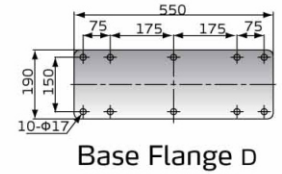
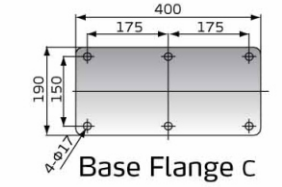
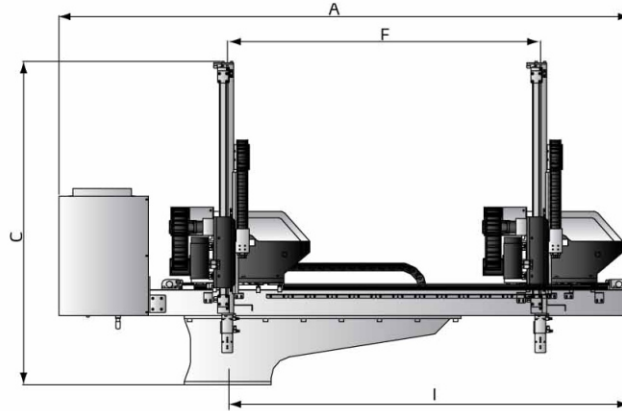
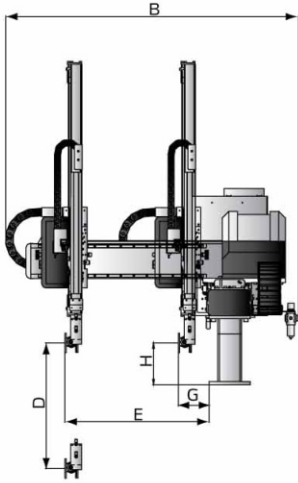

Three Axes Servo

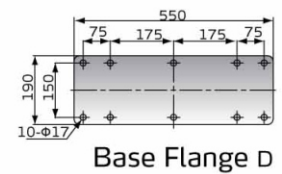
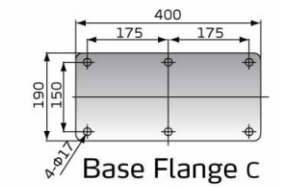
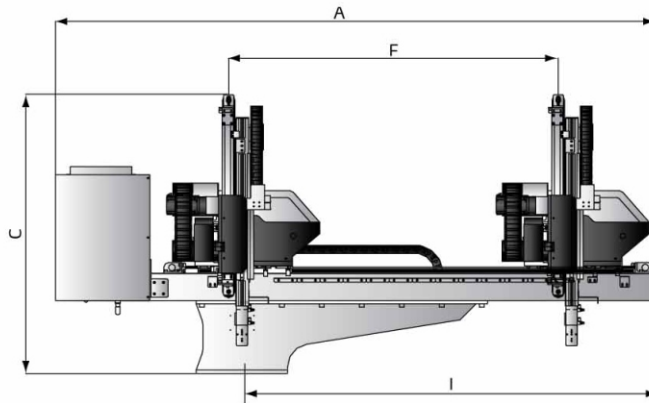
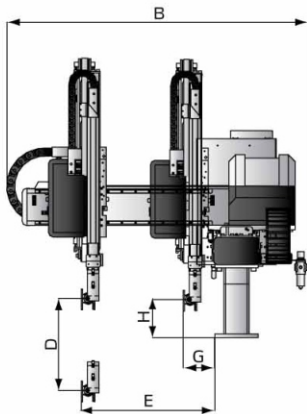

Three Axes Servo Telescopic

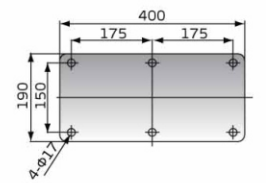
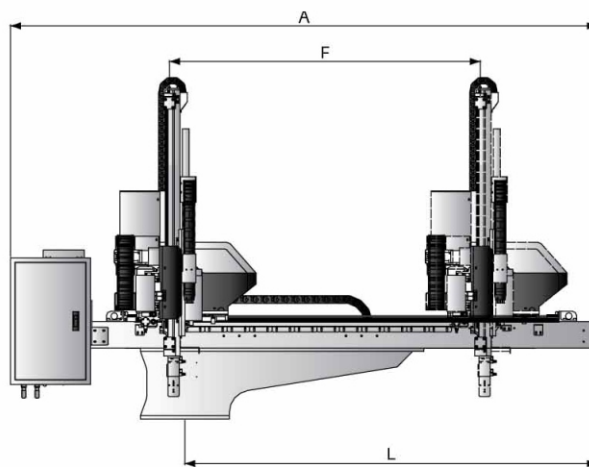
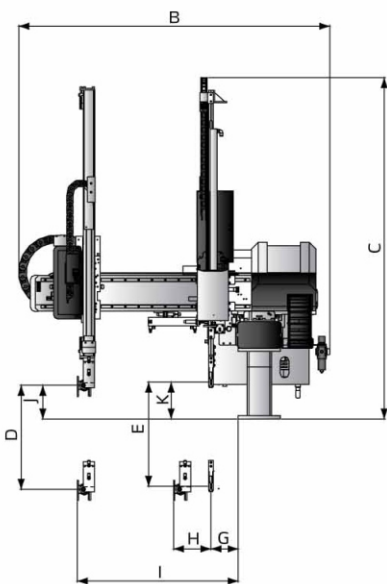

Base Flange C

Three Axes Servo Double-arms

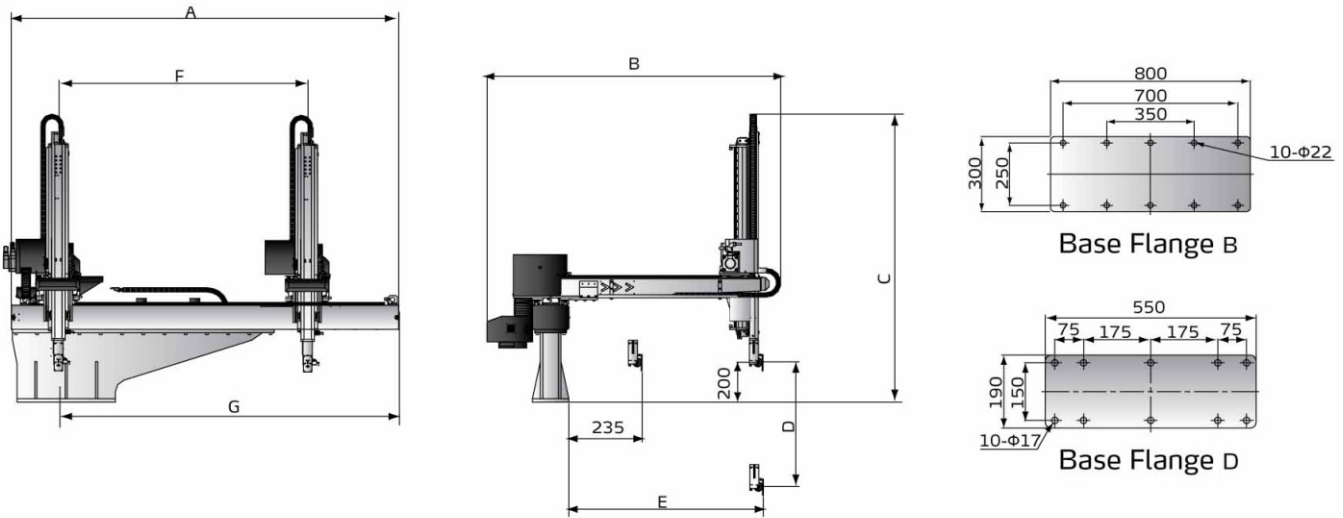

Medium Three Axes Servo Telescopic (Stationary-beam type)

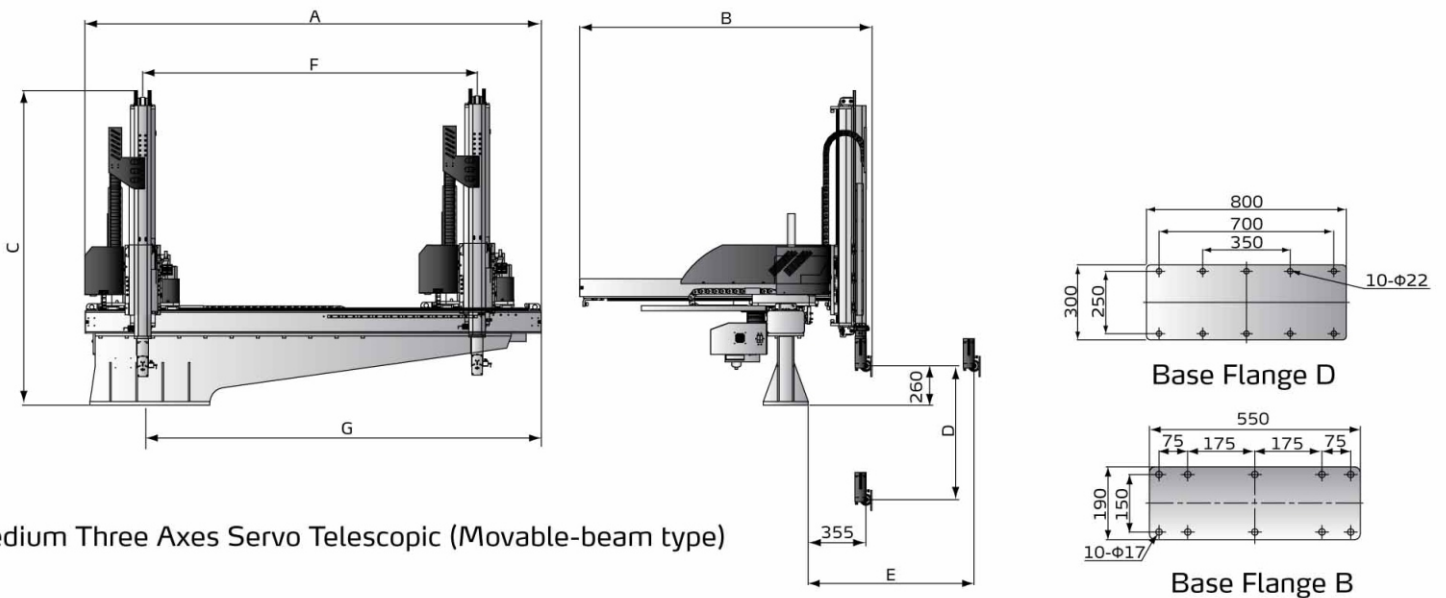

Medium Three Axes Servo Telescopic (Movable-beam type)

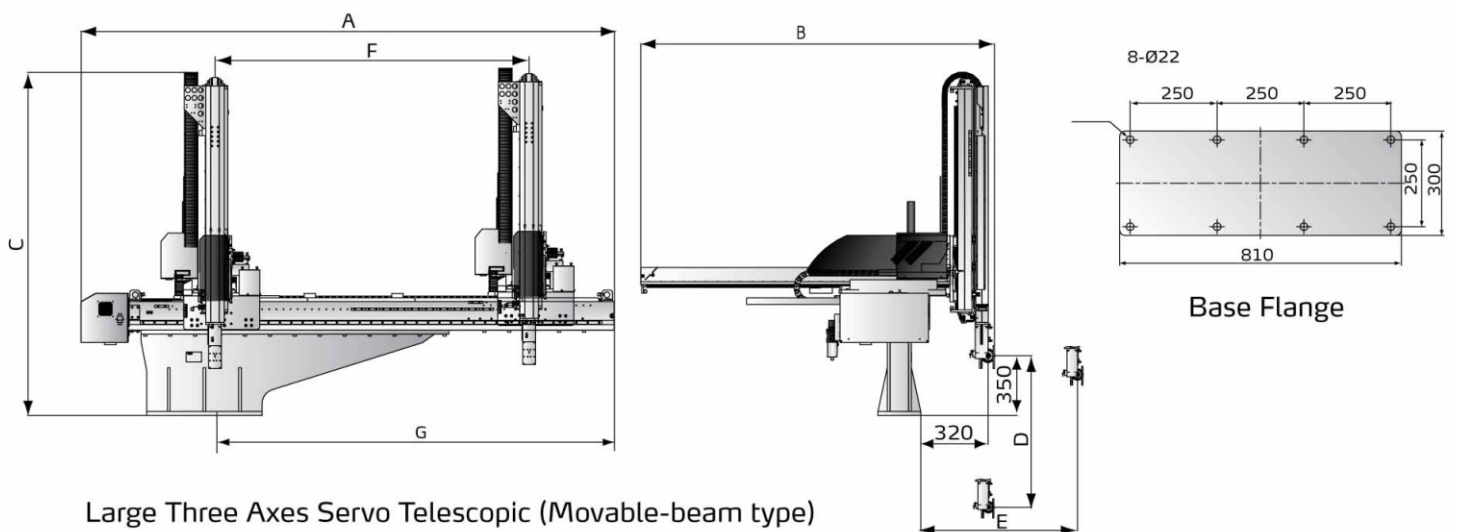

Large Three Axes Servo Telescopic (Movable-beam type)

ST3-S Series

Specifications

Model(Single stage)	ST3-700-1200-S	ST3-700-1400-S	ST3-800-1400-S	ST3-900-1600-S	ST3-1000-1600-S	ST3-1100-1800-S	ST3-1200-1800-S	
IMM (ton)	50~80	80~180	180~220	220~280	280~320	320~400	400~450	
Traverse Stroke (mm)	1200	1400	1400	1600	1600	1800	1800	
Crosswise Stroke (mm)	470	470	470	560	610	690	690	
Vertical Stroke (mm)	700	700	800	900	1000	1100	1200	
Max Load (with tool) (kg)	3	3	3	5	5	5	5	
Min Pick-out Time (sec)	1.3	1.3	1.3	1.4	1.4	1.6	1.6	
Min Cycle Time (sec)	5.2	5.2	5.2	5.8	6.2	6.5	6.8	
Air Pressure (bar)	4~6	4~6	4~6	4~6	4~6	4~6	4~6	
Max. Air Consumption (NI/cycle)*	4	4	4	4	4	4	4	
Weight (kg)	240	240	250	270	280	300	310	
Base Type	Base C	Base C	Base C	Base C	Base C	Base D	Base D	
Dimensions (mm)	A	2480	2680	2680	2880	2880	3120	3120
	B	1350	1350	1350	1450	1490	1570	1570
	C	1490	1490	1590	1690	1800	1900	2000
	D(max)	700	700	800	900	1000	1100	1200
	E(max)	610	610	610	710	775	855	855
	F(max)	1200	1400	1400	1600	1600	1800	1800
	G	155	155	155	155	165	165	165
	H	200	200	200	200	180	180	180
	I	1660	1860	1860	2060	2060	2260	2260

Model(Small telescopic)	ST3-700-1200T-S	ST3-700-1400T-S	ST3-800-1400T-S	ST3-900-1600T-S	ST3-1000-1600T-S	ST3-1100-1800T-S	ST3-1200-1800T-S	
IMM (ton)	50~80	80~180	180~220	220~280	280~320	320~400	400~450	
Traverse Stroke (mm)	1200	1400	1400	1600	1600	1800	1800	
Crosswise Stroke (mm)	425	425	425	525	650	680	680	
Vertical Stroke (mm)	700	700	800	900	1000	1100	1200	
Max Load (with tool) (kg)	3	3	3	5	5	5	5	
Min Pick-out Time (sec)	1.2	1.2	1.2	1.3	1.3	1.5	1.5	
Min Cycle Time (sec)	5	5	5	5.5	6	6.2	6.5	
Air Pressure (bar)	4~6	4~6	4~6	4~6	4~6	4~6	4~6	
Max. Air Consumption (NI/cycle)*	4	4	4	4	4	4	4	
Weight (kg)	240	240	250	270	280	300	310	
Base Type	Base C	Base C	Base C	Base C	Base C	Base D	Base D	
Dimensions (mm)	A	2480	2680	2680	2880	2940	3120	3120
	B	1365	1365	1365	1465	1550	1610	1610
	C	1220	1220	1270	1330	1380	1440	1490
	D	700	700	800	900	1000	1100	1200
	E	630	630	630	720	805	865	865
	F	1200	1400	1400	1600	1600	1800	1800
	G	155	155	155	155	155	155	155
	H	170	170	170	180	200	200	200
	I	1660	1860	1860	2060	2060	2260	2260

Notes: 1) "M" stands for middle mold detector. (suitable for three-plate mold.)

"EM12" stands for EUROMAP 12 communication interface.

"EM67" stands for EUROMAP 12 communication interface.

"N" stands for non-operation side, operation side without "N"

2) Power supply: 1Φ, 200~240V, 50/60Hz.

3) " * " Max. air consumption for vacuum device 60NI/min.

We reserve the right to change specifications without prior notice.



Model(Double-arm)	ST3-700-1400D-S	ST3-800-1400D-S	ST3-900-1600D-S	ST3-1000-1600D-S	ST3-700-1400DT-S	ST3-800-1400DT-S	ST3-900-1600DT-S	ST3-1000-1600DT-S	
IMM (ton)	80-180	180-220	220-280	280-320	80-180	180-220	220-280	280-320	
Traverse Stroke (mm)	1400	1400	1600	1600	1400	1400	1600	1600	
Crosswise Stroke (mm)	Main Arm	320	320	310	310	290	290	280	280
	Sub Arm	100	100	150	150	100	100	150	150
Vertical Stroke (mm)	Main Arm	700	800	900	1000	700	800	900	1000
	Sub Arm	750	850	950	1050	750	850	950	1050
Rated(Max)Load (with tool)(kg)	3	3	5	5	3	3	5	5	
Min Pick-out Time (sec)	1.3	1.3	1.4	1.4	1.2	1.2	1.3	1.3	
Min Cycle Time (sec)	5.2	5.4	5.8	6.2	5	5	5.5	6	
Air Pressure (bar)	4~6	4~6	4~6	4~6	4~6	4~6	4~6	4~6	
Max. Air Consumption (Nl/cycle)*	10	12	14	16	8	10	12	14	
Weight (kg)	260	270	280	320	280	290	320	350	
Base Type	Base C	Base C	Base C	Base C	Base C	Base C	Base C	Base C	
Dimensions (mm)	A	2460	2460	2840	2840	2460	2460	2840	2840
	B	1400	1400	1460	1460	1400	1400	1460	1460
	C	1535	1635	1735	1835	1220	1270	1340	1400
	D(max)	700	800	900	1000	700	800	900	1000
	E(max)	750	850	950	1050	750	850	950	1050
	F(max)	1400	1400	1600	1600	1400	1400	1600	1600
	G(max)	120	120	120	120	160	160	160	160
	H(max)	185	185	185	185	145	145	145	145
	I(max)	725	725	770	770	690	690	740	740
	J	150	150	150	150	175	175	175	175
	K	100	100	100	100	125	125	125	125
L	1860	1860	2060	2060	1860	1860	2060	2060	

Notes: 1) "M" stands for middle mold detector. (suitable for three-plate mold.)

"EM12" stands for EUROMAP 12 communication interface.

"EM67" stands for EUROMAP 12 communication interface.

"N" stands for non-operation side, operation side without "N"

2) Power supply: 1Φ, 200~240V, 50/60Hz.

3) " * " Max. air consumption for vacuum device 60Nl/min.

ST3-S Series

Model (Stationary-beam Type)	ST3-1300-2000T-S	ST3-1400-2000T-S	ST3-1500-2200T-S	ST3-1600-2200T-S	ST3-1700-2200T-S	
IMM (ton)	450-600T	450-600T	600-700T	700-850T	700-850T	
Traverse Stroke (mm)	2000	2000	2200	2200	2200	
Crosswise Stroke (mm)	800	900	900	1000	1100	
Vertical Stroke (mm)	1300	1400	1500	1600	1700	
Rated(Max)Load(with tool)(kg)	10	10	12	12	12	
Min Pick-out Time (sec)	3	3	3.2	3.3	3.4	
Min Cycle Time (sec)	12.5	13	13.5	14	15	
Air Pressure (bar)	4~6	4~6	4~6	4~6	4~6	
Max. Air Consumption (NI/cycle) *	6	6	6	6	6	
Weight (kg)	500	530	550	580	600	
Base Type	Base D	Base D	Base D	Base B	Base B	
Dimensions (mm)	A	2800	2800	3000	3000	3000
	B	2000	2100	2100	2250	2350
	C	1700	1750	1800	2050	2150
	D(max)	1300	1400	1500	1600	1700
	E(max)	1050	1150	1150	1250	1250
	F(max)	2000	2000	2200	2200	2200
	G	2700	2700	2900	2900	2900

Model (Movable-beam Type)	ST3-1200-1800MT-S	ST3-1300-2000MT-S	ST3-1400-2000MT-S	ST3-1500-2200MT-S	ST3-1600-2200MT-S	ST3-1700-2200MT-S	
IMM (ton)	300-450T	450-600T	450-600T	600-700T	700-850T	700-850T	
Traverse Stroke (mm)	1800	2000	2000	2200	2200	2200	
Crosswise Stroke (mm)	800	800	900	900	1000	1000	
Vertical Stroke (mm)	1200	1300	1400	1500	1600	1700	
Rated(Max)Load(with tool)(kg)	10(15)	10(15)	10(15)	10(15)	20(30)	20(30)	
Min Pick-out Time (sec)	2.8	3	3	3.2	3.3	3.4	
Min Cycle Time (sec)	12	12.5	13	13.5	14	15	
Air Pressure (bar)	4~6	4~6	4~6	4~6	4~6	4~6	
Max. Air Consumption (NI/cycle) *	6	6	6	6	6	6	
Weight (kg)	480	500	530	550	580	600	
Base Type	Base D	Base D	Base D	Base B	Base B	Base B	
Dimensions (mm)	A	2847	3047	3047	3247	3247	3247
	B	1617	1617	1717	1717	1817	1817
	C	1790	1840	1890	1940	2020	2070
	D(max)	1200	1300	1400	1500	1600	1700
	E(max)	1155	1155	1255	1255	1355	1355
	F(max)	1800	2000	2000	2200	2200	2200
	G	2250	2450	2450	2650	2650	2650

Notes: 1) "M" stands for middle mold detector. (suitable for three-plate mold.)

"EM12" stands for EUROMAP 12 communication interface.

"EM67" stands for EUROMAP 12 communication interface.

"N" stands for non-operation side, operation side without "N"

2) Power supply: 1Φ, 200~240V, 50/60Hz.

3) " * " Max. air consumption for vacuum device 60NI/min.

We reserve the right to change specifications without prior notice.

Model (Movable-beam Type)	ST3-1800-2400MT-S	ST3-1900-2400MT-S	ST3-2000-2800MT-S	ST3-2100-2800MT-S	ST3-2200-3000MT-S	
IMM (ton)	850-1400T	850-1400T	1400-1800T	1400-1800T	1800-2400T	
Traverse Stroke (mm)	2400	2400	2800	2800	3000	
Crosswise Stroke (mm)	1200	1200	1200	1400	1400	
Vertical Stroke (mm)	1800	1900	2000	2100	2200	
Rated(Max)Load(with tool)(kg)	20(30)	20(30)	20(30)	20(30)	20(30)	
Min Pick-out Time (sec)	3.6	3.6	3.8	3.8	4	
Min Cycle Time (sec)	16	17	17.5	18	19	
Air Pressure (bar)	4-6	4-6	4-6	4-6	4-6	
Max. Air Consumption (NL/cycle) *	6	6	6	6	6	
Weight (kg)	650	670	690	720	750	
Base Type	Base B	Base B	Base B	Base B	Base B	
Dimensions (mm)	A	3447	3447	3847	3847	4047
	B	2017	2017	2017	2270	2270
	C	2120	2170	2220	2270	2320
	D(max)	1800	1900	2000	2100	2200
	E(max)	1555	1555	1555	1755	1755
	F(max)	2400	2400	2800	2800	3000
	G	2850	2850	3250	3250	3450

Model(Large telescopic)	ST3-1800-2400LT-S	ST3-2000-2800LT-S	ST3-2200-3000LT-S	ST3-2600-3200LT-S	ST3-3000-3400LT-S	
IMM (ton)	850 ~ 1400T	1400 ~ 1800T	1800 ~ 2400T	2400 ~ 3000T	3000 ~ 3600T	
Traverse Stroke (mm)	2400	2800	3000	3200	3400	
Crosswise Stroke (mm)	1340	1500	1500	1660	1820	
Vertical Stroke (mm)	1800	2000	2200	2600	3000	
Rated(Max)Load(with tool)(kg)	40(60)	40(60)	40(60)	40(60)	40(60)	
Min Pick-out Time (sec)	3.8	4.0	4.2	4.5	5.0	
Min Cycle Time (sec)	20	22	24	26	28	
Air Pressure (bar)	4 ~ 6	4 ~ 6	4 ~ 6	4 ~ 6	4 ~ 6	
Max. Air Consumption (NL/cycle) *	8	8	8	8	8	
Weight (kg)	920	950	990	1010	1080	
Dimensions (mm)	A	3800	4200	4400	4600	4800
	B	2500	2650	2650	2820	2980
	C	2400	2500	2600	2800	3000
	D (max)	1800	2000	2200	2600	3000
	E (max)	1750	1900	1900	2050	2250
	F (max)	2400	2800	3000	3200	3400
	G	2900	3300	3500	3700	3900

Notes: 1) "M" stands for middle mold detector. (suitable for three-plate mold.)

"EM12" stands for EUROMAP 12 communication interface.

"EM67" stands for EUROMAP 12 communication interface.

"N" stands for non-operation side, operation side without "N"

2) Power supply: 1Φ, 200-240V, 50/60Hz.

3) " * " Max. air consumption for vacuum device 60NL/min.

We reserve the right to change specifications without prior notice.

Shini Group

Addr: No. 23, Minhe St., Shulin Dist.,
New Taipei, Taiwan

Tel: +886 2 2680 9119

Fax: +886 2 2680 9229

Email: shini@shini.com

Factories:

- Taiwan
- Dongguan
- Pinghu
- Ningbo
- Chongqing
- Pune

2017-08-15-04 Copyrights Reserved.

www.shini.com