



Volumetric Doser

SCM Single Color Doser



Refer carefully to this manual before operation.

SCM Series

■ Coding Principle

SCM - x- xx - xx - xx

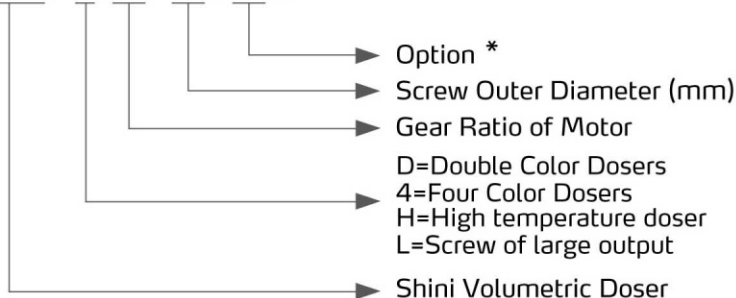

Notes: *

MS=Equipped with Mixer

CE=CE Conformity

■ Features

- Dosing screws are chrome plated for durability.
- Unit is comprised of standard modules for ease of cleaning, disassembly and interchangeability.
- Hopper magnets are equipped in standard base to avoid molding machine screw damage.
- External signals can be directly input to control box.
- The current mode can be recorded without interrupted by power failure.
- Compulsory material cleaning makes it easier to replace masterbatch.
- Applicable on extrusion machines, just need to make a few wire replacements.
- Rotating speed can be automatically adjusted according to extruder processing speed, which maintains the fixed proportion of masterbatch.
- 50 recipes are available for permanent recording of material discharging time and finished products weight (for extruder, it is max. throughput per minute).
- Use brushless DC motor and free from maintenance.
- Both masterbatch blockage and overload can be detected, then machine will halt and sound an alarm.
- Based on customers demand, mold cycles can be set to add additives periodically so that micro-metering can be achieved.
- SCM-4 is standard equipped with a main hopper and a blender.
- Equipped with RS485 communication function (SCM-4 excluded).



SCM-4



SCM-D Double-color Doser



Heavy Base (optional)

Options

- For collocating with SHD-100~300 or SHD-160U~450U dryers, heavy base should be selected.
- SCM-4 is capable of adding four kinds of masterbatch at most.
- High temperature doser SCM-H is optional for applying to PET high temperature situation; the water runs in its cooling part must be room temperature water.
- Blender is an option for customers to make materials evenly mixed.
- Main material hopper is optional equipment for customers to feed main material.
- Low level sensor can be opted to give an alarm when masterbatch is insufficient.
- Screws with diameter of 30mm/1.18inch can meet customers' requirements of large output.
- Optional 100kg/220lb base to satisfy maximum discharge volume(without mixing function).



SCM-H

Application

SCM series volumetric dosers are suitable for auto-proportional mixing of virgin materials, regrinds, master batch or additives. A gear motor with gear ratio of 38:1 is coupled to a dosing screw of 12, 16, 20 or 30mm (0.47, 0.63, 0.79 or 1.18 inch) in diameter to give a total of four models with output ranging from 0.1~110kg/hr (0.22~242.5lb). Double-color dosers is available for collocating with any two of single color dosers if required. Five components automatic mixing can be realized if customers adopt four-color dosers.

Working Principle

Signals from control cabinet are sent to motor, and then motor begins to work. The rotary force is transferred to the dosing screw through shaft connector. Color additives in hopper fall into the groove of conveying screw, then are taken to hopper base by rotating action of the screw.

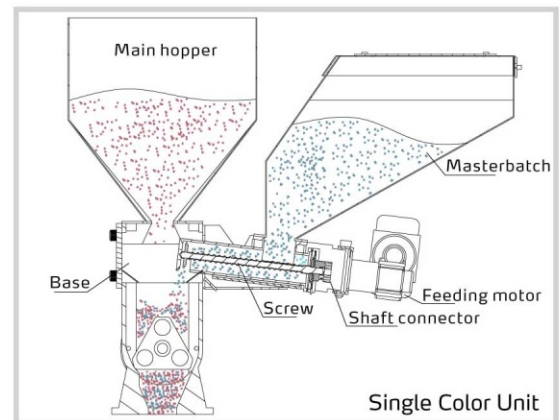

SCM Series

Outline Drawings

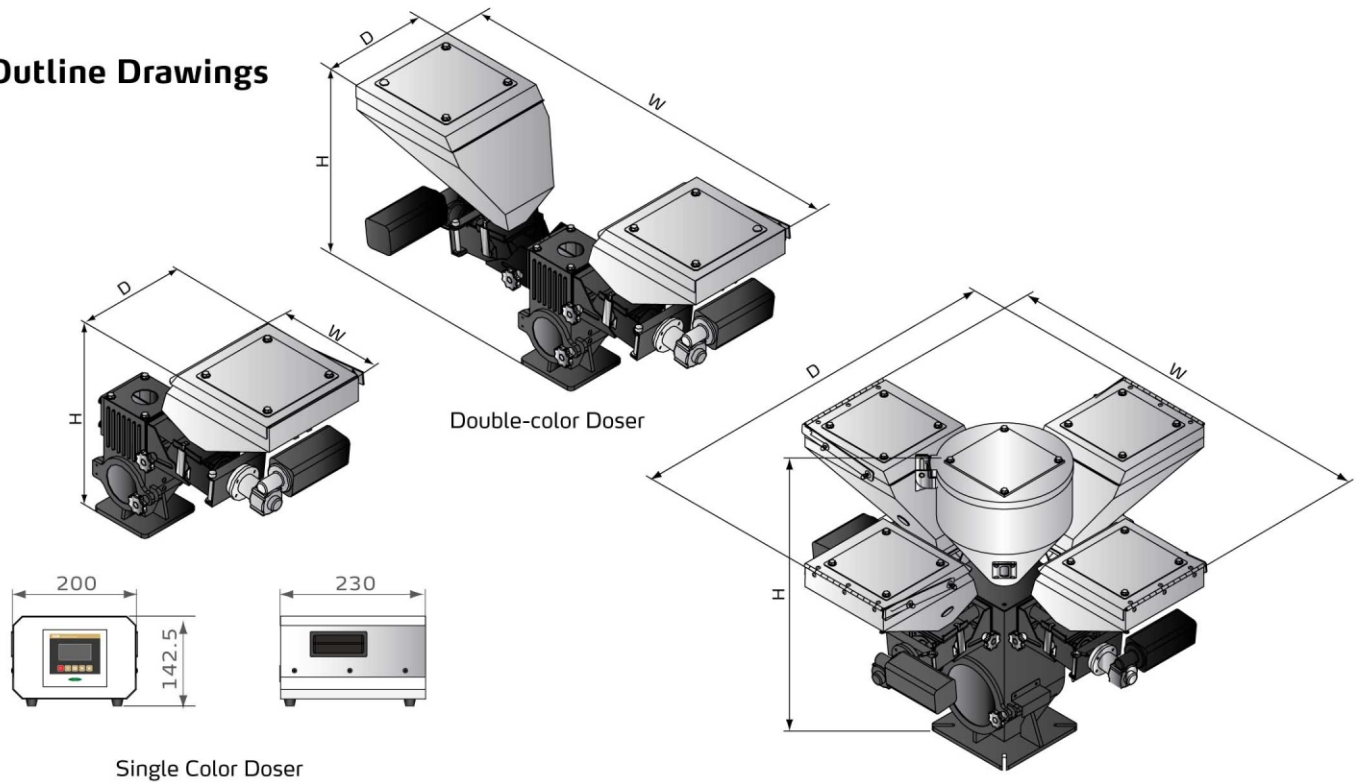

Single Color Doser

Four color Doser

Specifications

Model		SCM-12	SCM-16	SCM-20	SCM-30	SCM-D	SCM-4	
Motor Power (kW, 50/60Hz)		0.06	0.06	0.06	0.06	0.06 × 2	0.06 × 2	
Output Power of Mixer (kW, 50 / 60Hz)		0.09	0.09	0.09	0.09	0.09	0.09	
Screw External Dia.		12mm/0.47"	16mm/0.63"	20mm/0.79"	30mm/1.18"	**	**	
Output Capacity	kg/hr	0.1-10	0.5-30	3-60	8-110	*	*	
	lb/hr	0.22-22	1.1-66	6.6-132	17.6-242.5	*	*	
Storage Hopper	L	10	10	10	10	10	10	
	gal	2.6	2.6	2.6	2.6	2.6	2.6	
Gear Ratio		38:1	38:1	38:1	38:1	38:1 / 38:1	38:1	
Main Material Hopper	L	Optional(15)	Optional(15)	Optional(15)	Optional(15)	Optional(15)	Standard(15)	
	gal	Optional(4.0)	Optional(4.0)	Optional(4.0)	Optional(4.0)	Optional(4.0)	Standard(4.0)	
Mixer		Optional	Optional	Optional	Optional	Optional	Standard	
Heavy-duty Base		Optional	Optional	Optional	Optional	Optional	-	
Dimensions	H(mm)	mm	520	520	520	520	736	
		inch	20.5	20.5	20.5	20.5	29	
	W(mm)	mm	610	610	610	610	1045	1125
		inch	24	24	24	24	41	44.3
	D(mm)	mm	335	335	335	335	410	1125
		inch	13	13	13	13	16	44.3
Weight	kg	29	29	29	29	50	75	
	lb	64	64	64	64	110	165	

Notes: 1) "*" stands for the output capacity depends on model selected, data of the single color doser can be a reference. For example: SCM-D-12 / 16, output capacity 0.6~40kg/hr(1.3~88lb/hr).

2) "*" stands for external dia. of screw is up to model selected.

3) For additional mixer, add "MS" at the end of model code.

4) When selecting screws with diameter of 30mm/1.2inch, the machine model should be followed by "L" to distinguish it from other three kinds of interchangeable screws.

5) All output capacities of above models are base on data from bulk density 1.2kg/L(10lb/gal), dia.

2-3mm/0.08-0.12inch masterbatch in a test criteria of continuous running.

6) Power supply: 1Φ, 115/230V, 50/60Hz.

Shini Group

Addr: No. 23, Minhe St., Shulin Dist.,
New Taipei, Taiwan

Tel: +886 2 2680 9119

Fax: +886 2 2680 9229

Email: shini@shini.com

Factories:

- Taiwan
- Dongguan
- Pinghu
- Ningbo
- Mumbai

2016-09-15-04 Copyrights Reserved.

www.shini.com