

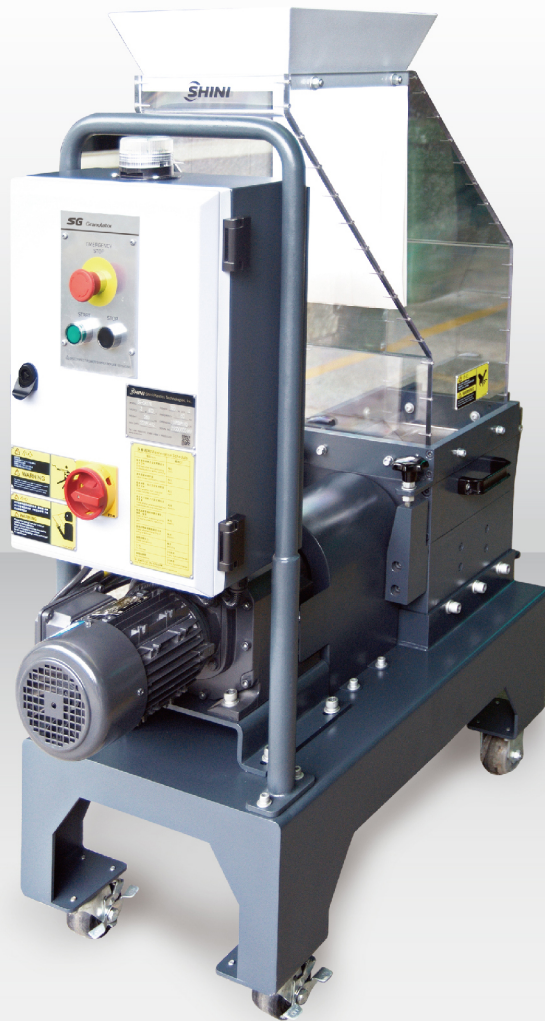

Screenless Granulator

SG-2427N



Refer carefully to this manual before operation.

SG-14/24N/24T

■ Coding Principle

SG - xx xx x - xx

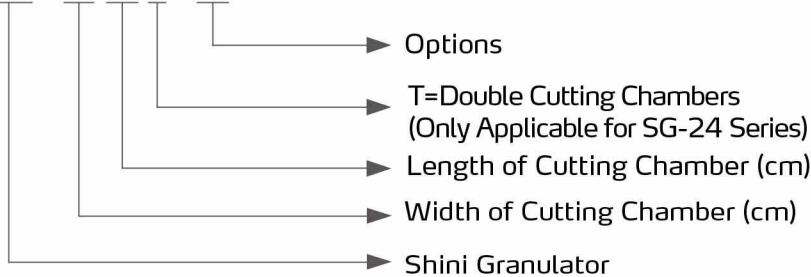

SG-1417

■ Features

- Adopt well-known gear motor of foreign brand, SG-14/24N series features steady performance, long service life and large transfer torque.
- Adopt two well-known gear motors, SG-24T series have two cutting chambers working simultaneously to provide reliable performance and high torque.
- SG-14/24N series teeth cutters and cutting blades are integrally fitted in one cutting chamber. SG-24T series feature integral design of double teeth cutters and cutting blades. Staggered blades make the initial cutting and teeth cutters cut the materials into desired size. Regrinds could be used with virgin materials.
- New-type inclined teeth cutter reduces the possibility of stress concentration, then enhance cutter lifespan and reduction in dust .
- SG-14/24T/24N series motor shaft and rotor shaft are connected by shaft coupling thus ensuring smooth cutting action and convenient motor replacement.
- SG-24N series adopt moment arm flange to secure reduction gear and ensure smooth running with low noise.
- When motor blockage occurs, the machine will alarm visibly and enable motor to run reversely. It will return to normal operation automatically after the trouble is clear.
- Compact design, small footprint for easy cleaning and maintenance.
- Transparent PC feeding hopper.



SG-2446T

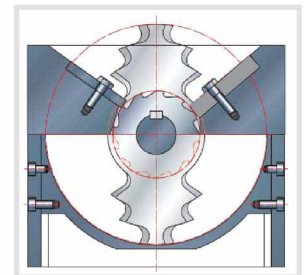

Section View of
Trapezoid Teeth Cutter

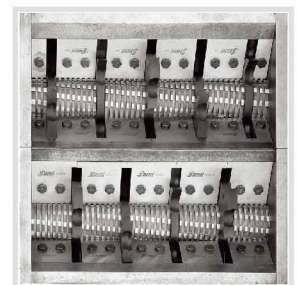

SG-24T
Double Teeth Cutter

Application

1. Material storage tank
2. Material pipe
3. Proportional valve
4. Photosensor hopper
5. Vacuum pipe
6. Auto loader
7. Screenless granulator
8. Vacuum hopper
9. Hopper dryer

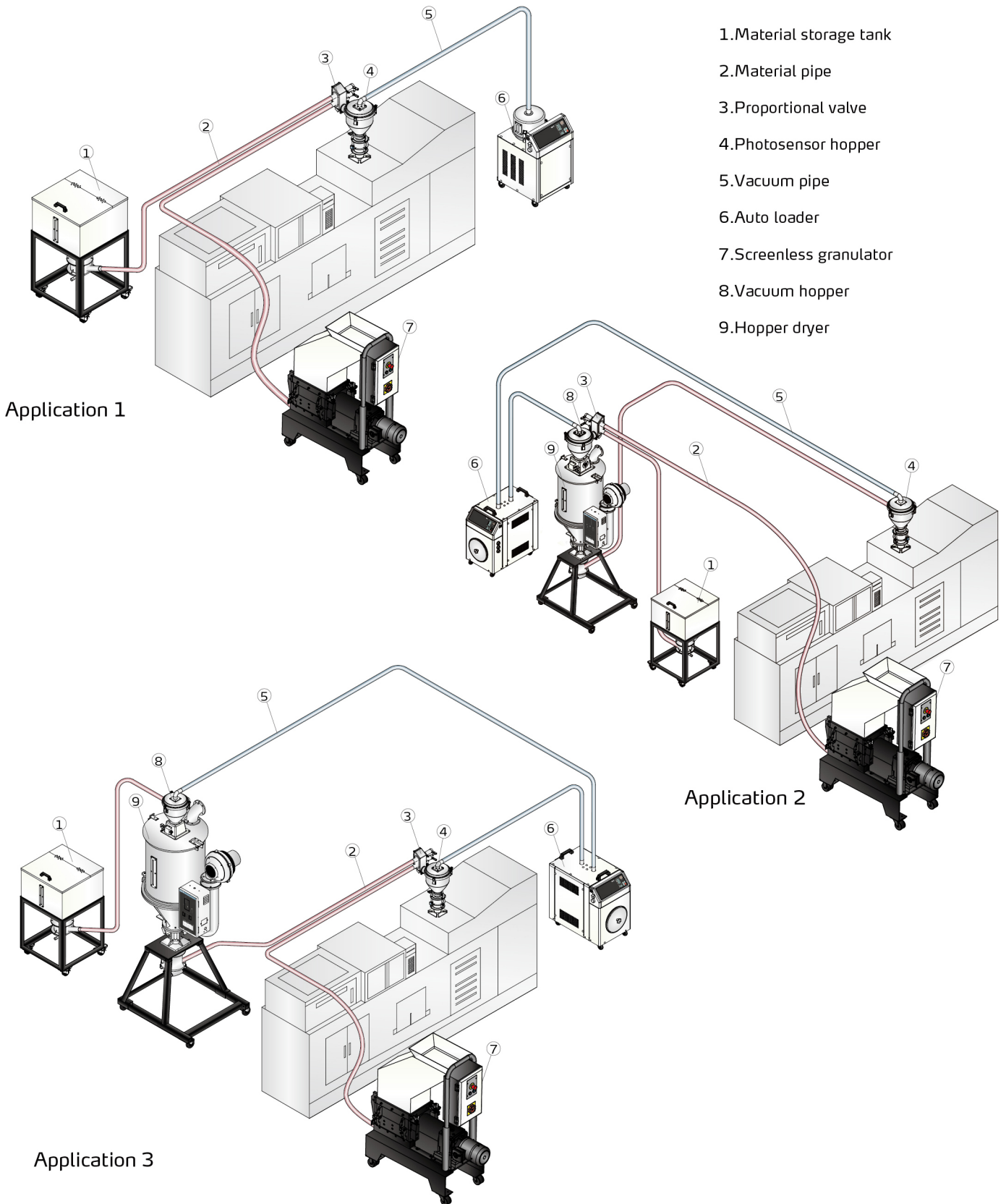

Application 1

Application 2

Application 3

SG-14/24N/24T

Options

30-Sec Instant Recycling System (Patented Product)

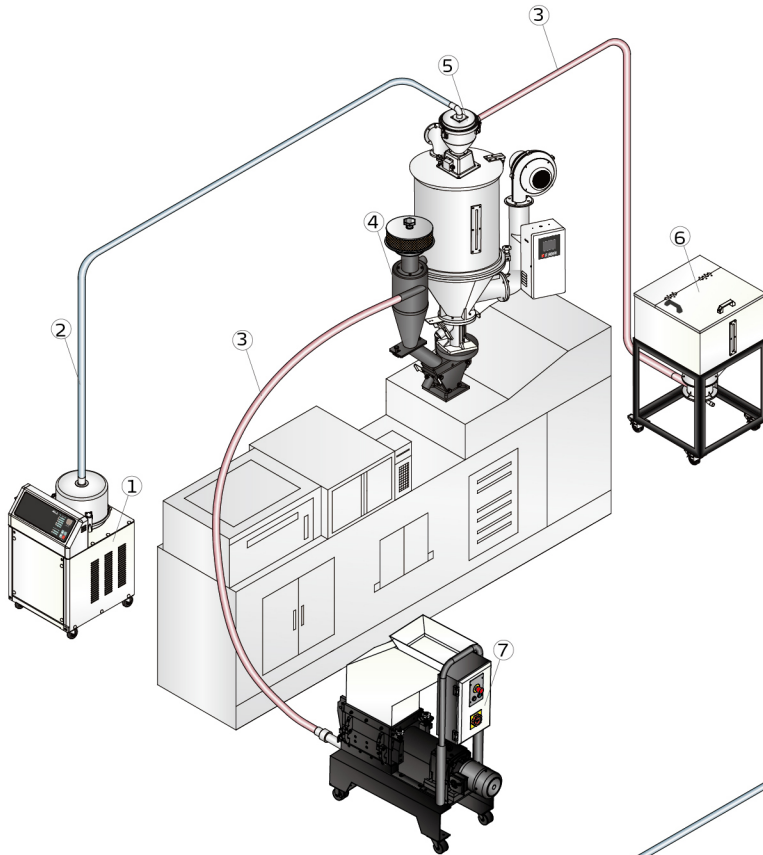

1. Hopper loader
2. Vacuum pipe
3. Material pipe
4. 30-Sec instant recycling system
5. Vacuum hopper
6. Material tank
7. Screenless granulator

VR Type 30-Sec Instant Recycling

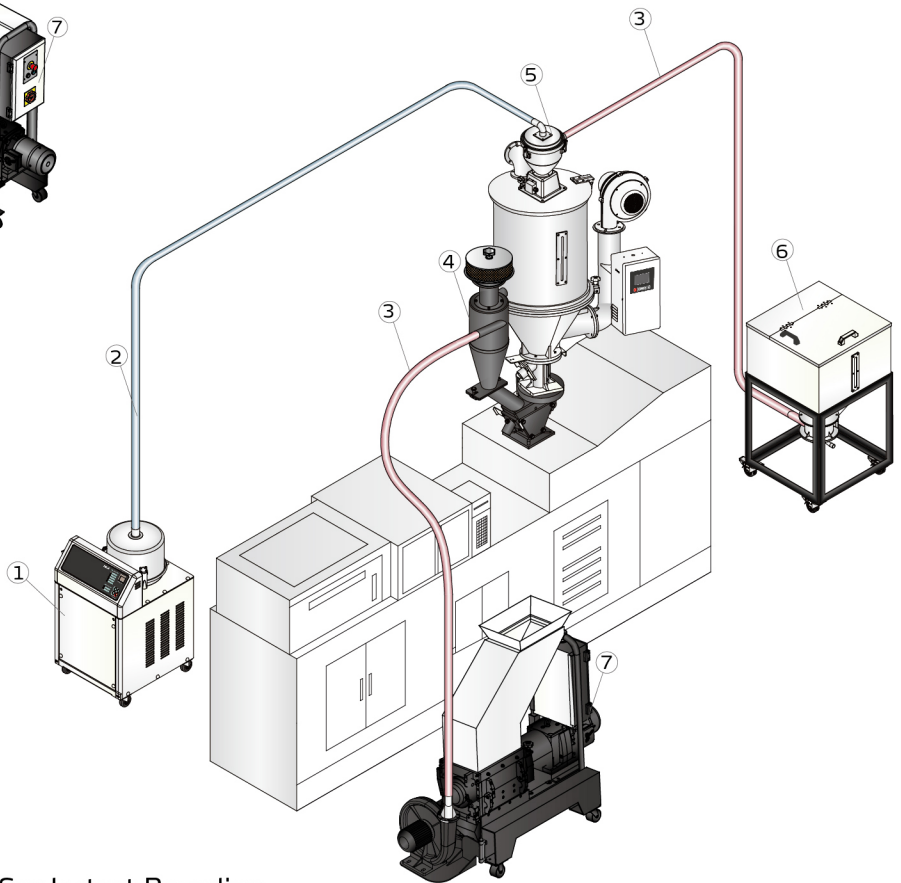

BR Type 30-Sec Instant Recycling

Regrind Conveying via Blower & Cyclone (BC Type)



This device utilizes loading blower to convey regrind into the cyclone dust collector to separate the regrind from the air and then the regrind will fall into storage hopper or cloth bag. Applicable to SG-24N/24T series.

Dust Separator (DS Type)

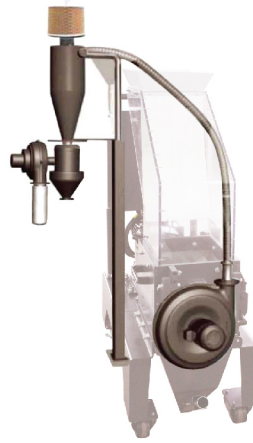

Dust Separator (DS type) can separate the dust in the regrind for immediate recycle use. The dust will be kept in filter bag, thus working environment will be maintained clean. This device ensures full use of regrind to avoid material wasting and enhance the economical returns. Applicable to SG-24N/24T series.

Full-receiver Alarm Device

Full-receiver alarm device can help to realize unmanned operation and no materials will be wasted. Whenever the regrind level reaches the motor position, the machine will be forced to stop and be cut off via it is sensor, thus stop the granulator and warn the user by sounding an alarm. Applicable to SG-24N/24T series.



Manual Collection Bin

Manual collection bin helps to collect and store regrind. Applicable to SG-24T series.

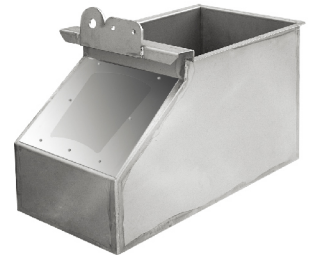

Teeth Cutter

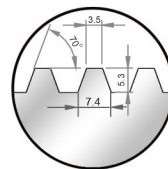

Narrow

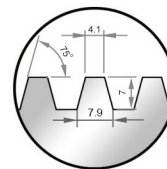

Standard

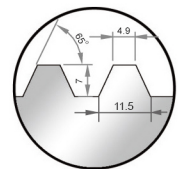

Dilated

- Stainless Steel Made Feed Port and Storage Tank, add "R" at the end of the model code.

SG-14/24N/24T

Outline Drawings

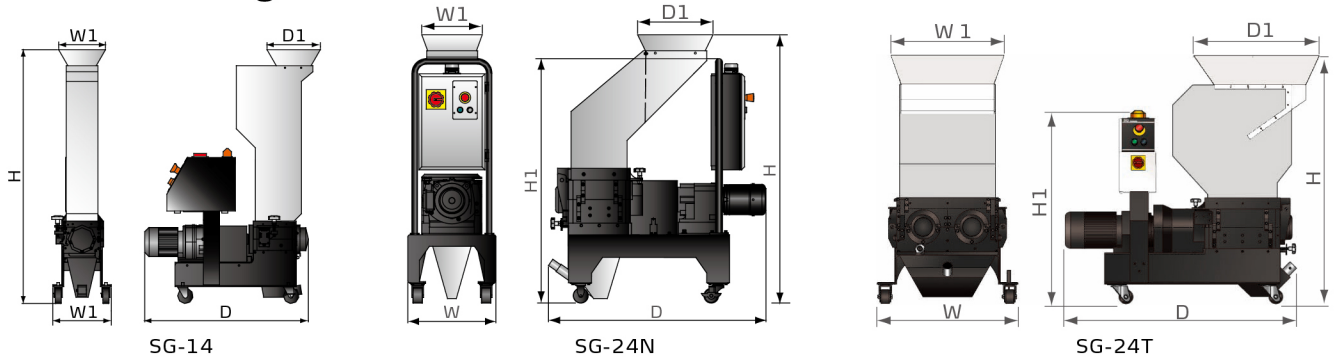

SG-14/24N/24T Specifications

Model	SG-1411	SG-1417	SG-2417N	SG-2427N	SG-2436N	SG-2446N	SG-2436T	SG-2446T		
Motor Power (kW, 50/60Hz)	0.37/0.45	0.37/0.45	0.75/0.86	0.75/0.86	1.5/1.75	2.2/2.57	2.2x2/2.55x2			
Rotating Speed (rpm, 50/60Hz)	26/32	26/32	27/33	27/33	27/33	27/33	27/33	27/33		
Material of Teeth Cutter	SKD11	SKD11	SKD11	SKD11	SKD11	SKD11	SKD11	SKD11		
Quantity of Staggered Cutter	1	2	1	2	3	4	7	9		
Quantity of Teeth Cutter	2	3	2	3	4	5	/	/		
Quantity of Large Teeth Cutter	/	/	/	/	/	/	7	9		
Quantity of Small Teeth Cutter	/	/	/	/	/	/	2	2		
Cutting Chamber	mm	140 x 110	140 x 175	240 x 175	240 x 270	240 x 365	240 x 460	505 x 365	505 x 460	
	inch	5.5 x 4.3	5.5 x 6.9	9.4 x 6.9	9.4 x 10.6	9.4 x 14.4	9.4 x 18.1	19.9x14.4	19.9x18.1	
Max. Output Capacity (kg/hr, 50/60HZ)	2	3	3.5	6/6.5	8.5/9	11/11.6	20	25		
Noise Level dB(A)	60-68	60-68	80-85	80-85	80-85	80-85	80-85	80-85		
Dimension	H	mm	1080	1080	1370	1370	1400	1410	1360	1360
		inch	42.5	42.5	53.9	53.9	55.1	55.5	53.5	53.5
	H1	mm	/	/	1248	1248	1248	1248	1060	1060
		inch	/	/	49.1	49.1	49.1	49.1	41.7	41.7
	W	mm	290	290	425	425	425	425	773	773
		inch	11.4	11.4	16.7	16.7	16.7	16.7	30.4	30.4
	W1	mm	235	235	308	308	308	308	620	620
		inch	9.3	9.3	12.1	12.1	12.1	12.1	24.4	24.4
	D	mm	740	785	977	1112	1253	1410	1269	1365
		inch	29.1	30.9	38.5	43.8	49.3	55.5	50	53.7
	D1	mm	210	266	289	385	475	546	688	785
		inch	8.3	10.5	11.4	15.2	18.7	21.5	27	30.9
Weight	kg	83	92	215	240	257	330	530	560	
	lb	183	203	474	529	567	728	1168	1235	

- Notes: 1) Max. Capacity of the machine is subject to the size and composition of the material.
 2) Noise level will varies with different materials and motor types.
 3) SKD11 is JIS steel grade.
 4) Teeth cutter with width of 3mm is standard, and 4mm is optional (SG-14).
 Trapezoidal teeth cutter is standard; narrow and dilated one are optional (SG-14N/24T).
 5) To avoid plastic from sticking to the blades, all materials should be crushed at normal temperature.
 6) Power supply: 3Φ, 230/400/460/575 VAC, 50/60Hz.

We reserve the right to change specifications without prior notice.