



# Shredder

SGS-6080S



Refer carefully to this manual before operation.

## ■ Coding Principle

SGS - xx xxx S

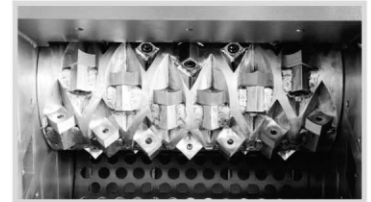
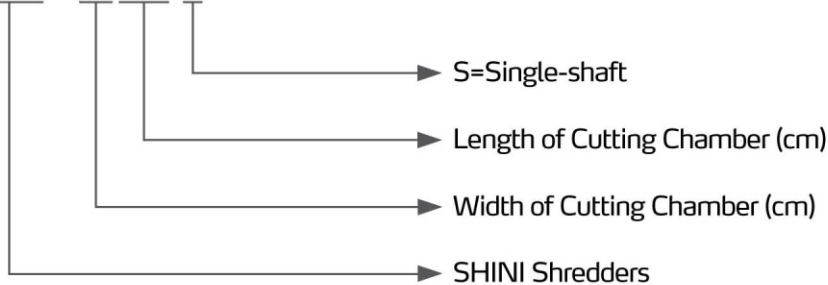

Cutters of Single-shaft Shredder

## ■ Features

- Milling smashing design, cutting in medium speed, low noise, low energy consumption, smashing in uniform size. Screen mesh will be chosen in accordance with customer's requirement.
- Rotor uses the square knife block of indentation on the surface to reduce the friction heat. When one of the angles of the cutter is broken, it can simply inter-change the cutter to improve the cutting efficiency.
- The automatically hydraulic device can be adjusted to achieve optimum production.
- Equipped with independent control panel, there are automatic and manual operational modes to choose, quite flexible and safe.
- Machine connects the transmission shaft and belt wheel through V-shape belt to make operating balance and dismantle convenient.
- Mount anti-vibration pads at the machine feet for reducing vibration during shredding.
- Have reverse alarm function for making the machine fail to start and flashing the alarm light when the power supply is mistakenly connected.
- Possess multiple protections, such as current relay and motor overload protection.



SGS-4860S

## ■ Application

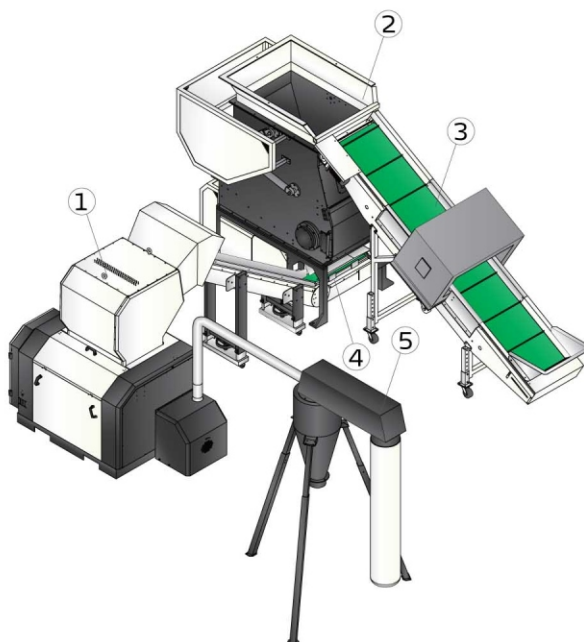

- 1.Sound-proof central granulator
- 2.Shredder
- 3.Belt conveyors with metal detector
- 4.Up-feed belt conveyor
- 5.Dust separator

## Outline Drawings

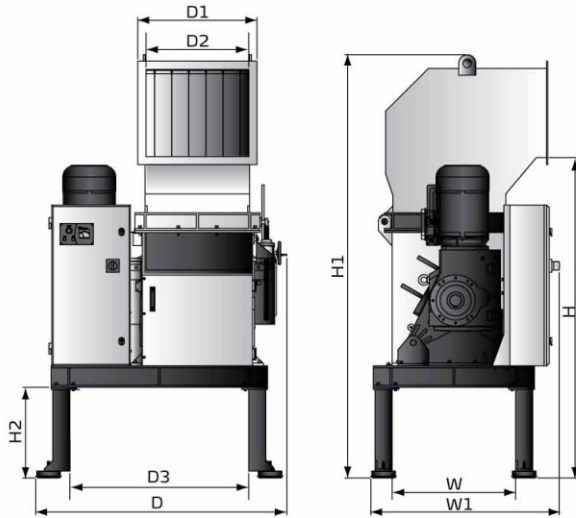

SGS-4860S

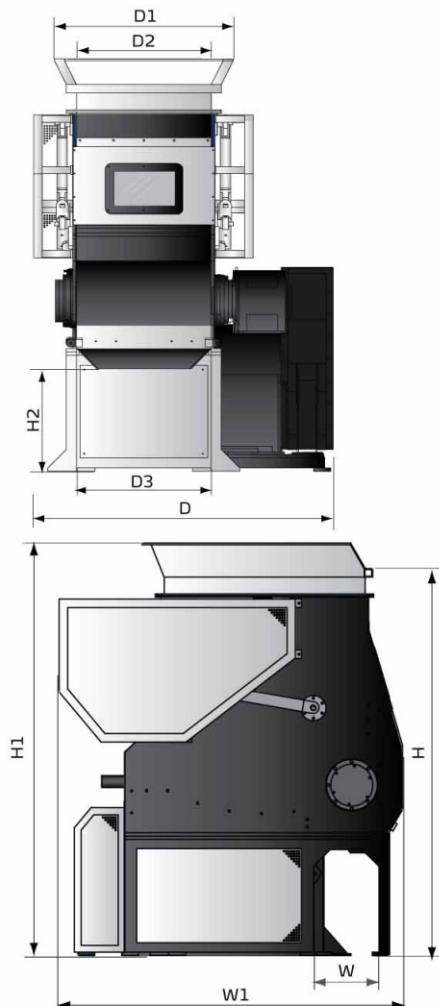

SGS-6080S/SGS-75120S

## Specifications

Model	SGS-4860S	SGS-6080S	SGS-75120S		
Motor Power (kW, 50/60Hz)	15	37	55		
Speed of Main Shaft (rpm, 50/60Hz)	65	73	73		
Motor Power of Hydraulic System (kW)	-	3.7	3.7		
Material of Cutters	SKD11	SKD11	SKD11		
Number of Fixed Blades	2	4	6		
Number of Rotating Blades	39	57	93		
Cutting chamber size	mm	480 × 600	600 × 800	750 × 1200	
	inch	18.9 × 23.6	23.6 × 31.5	29.5 × 47.2	
Max Throughput Capacity (kg/hr, 50/60Hz)	400	1000	1500		
Noise Level dB(A)	110	110	110		
Dia. of Screen Hole (Φ30 mm)	√	√	√		
Dia. of Screen Hole	mm	○ Φ20, Φ25, Φ35			
	inch	○ Φ0.79, Φ0.98, Φ1.38			
Regrind Conveying Device	-	○	○		
Dimensions	H (mm)	mm	1900	2300	2560
		inch	74.8	90.6	100.8
	H1 (mm)	mm	2500	2455	2715
		inch	98.4	96.7	106.9
	H2 (mm)	mm	530	610	770
		inch	20.9	24	30.3
	W (mm)	mm	720	390	440
		inch	28.3	15.4	17.3
	W1 (mm)	mm	1100	2040	2410
		inch	43.3	80.3	94.9
	D (mm)	mm	1450	1780	2265
		inch	57	70	89
	D1 (mm)	mm	600	1060	1460
		inch	23.6	41.7	57.5
	D2 (mm)	mm	700	800	1200
		inch	27.6	31.5	47.2
	D3 (mm)	mm	1045	800	1200
		inch	41.1	31.5	47.2
Weight (kg)	kg	1620	3970	5500	
	lb	3,571	8,752	12,125	

Notes: 1) "√" standard, "○" Stands for options.

2) Max capacity of the machine is subject to diameter of screen mesh and composition of material. The above data is based on 5 mins continually shredding of PVC sprue, 300-500KG capacity generally ranges from 300-500kg for granulating piping tube.

3) Noise level will vary with different materials and motor types.

4) SKD11 are JIS code number.

5) For avoiding plastic to adhibit the blade, all materials should be crushed at normal temperature.

6) Power supply: 3Φ, 230 / 400 / 460 / 575VAC, 50 / 60Hz.

## 信易集團

地址: 台灣省新北市樹林區民和街23號

電話: +886 2 2680 9119

傳真: +886 2 2680 9229

Email: [shini@shini.com](mailto:shini@shini.com)

### 製造工廠

- 台灣
- 東莞
- 平湖
- 寧波
- 重慶
- 浦那

2016-03-15-04 版權所有 翻版必究

[www.shini.com](http://www.shini.com)