

"Budget" Hopper Dryer

SHD-12-EB



Refer carefully to this manual before operation.

SHD-EB "Budget"

■ Coding Principle

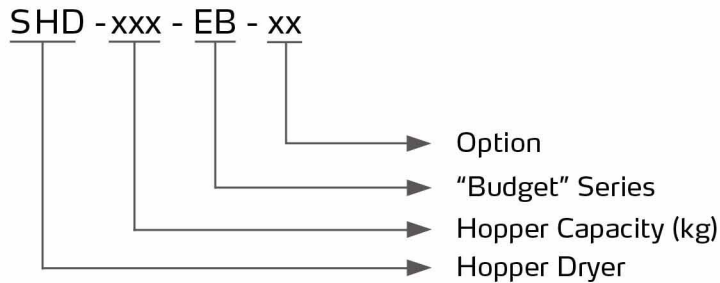

■ Features

- Adopt hot air diffuser to gain an even hot air flow to improve drying efficiency.
- Hot air inlet elbow design can prevent dust piling up at bottom of the pipe heaters so as to avoid burning.
- All material contact surfaces are made of stainless steel to eliminate material contamination.
- Hopper separated from its base, ensuring convenient cleaning.
- Adopts heat-insulated blower to prolong blower lifespan.
- SHD-EB series has standard timer
- SHD-EB series of blowers equip with overheat protectors



Hopper Inside

■ Working Principle

In the drying process, hot air with constant temperature is blown by a blower into a two-layer insulated hopper to dry the materials. Moisture will be separated out and taken away by hot air, thus to gain a satisfied drying effect.

Air blown out of blower became high temperature drying air after being heated. Through screen protector and hole screen, hot air can be equably dispersed in the material of storage tank (see picture). Hot air recycler is optional so the air enter drying blower after being filtered to form a closed loop circle and save electricity.

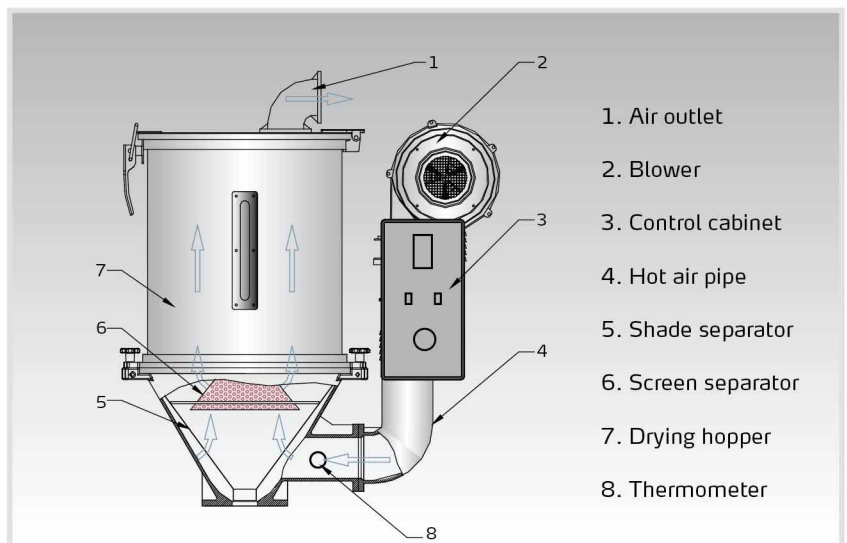

■ Application

SHD-EB hopper dryers are used for drying hygroscopic plastics, such as PS, PP, and ABS etc., which can reach the highest drying temperature up to 160°C. In addition, multiple accessories are optional to realize different functions, such as recycling hot air and filtering metal impurities in the materials. Moreover, with the floor stand, it makes floor mount of the machine available.

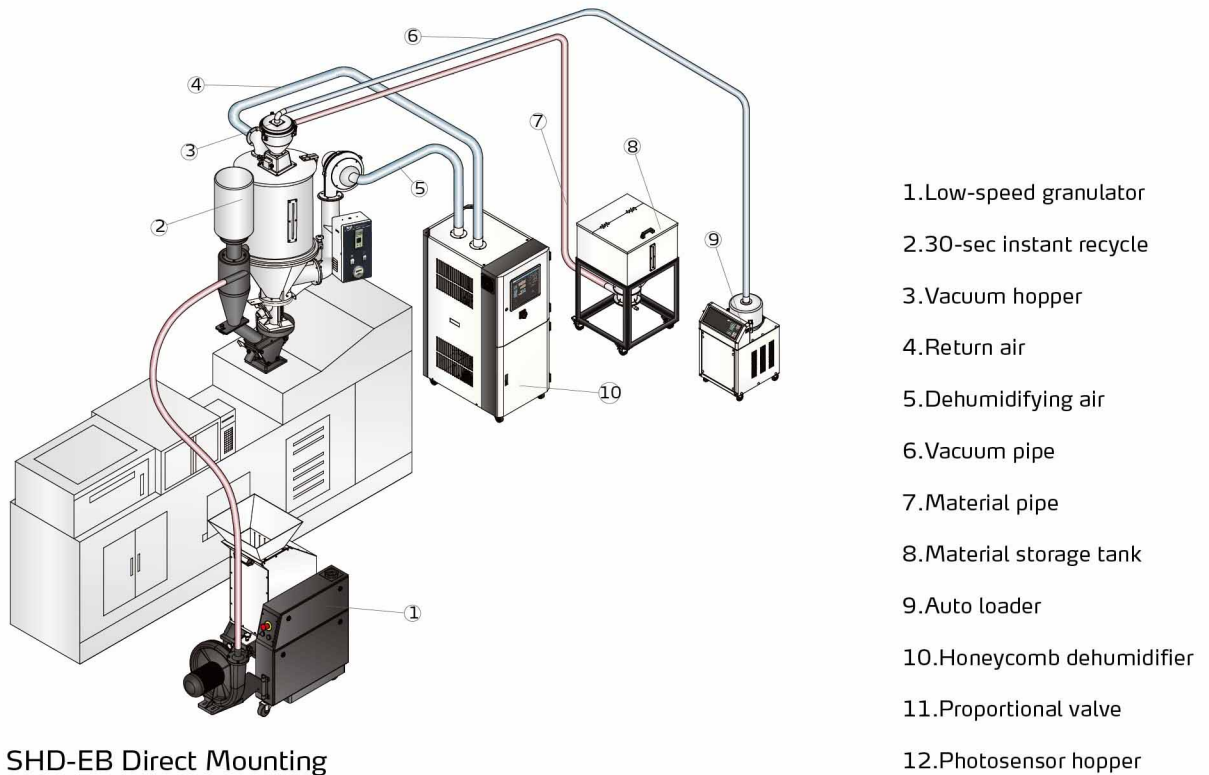

SHD-EB Direct Mounting

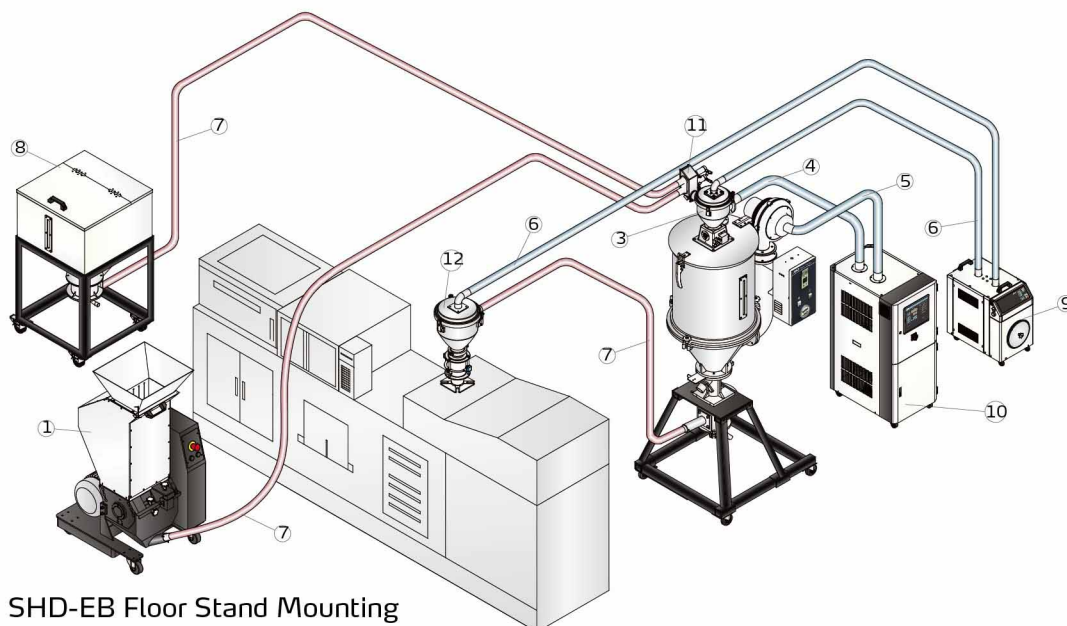

SHD-EB Floor Stand Mounting

SHD-EB "Budget"

Options

Magnetic Base

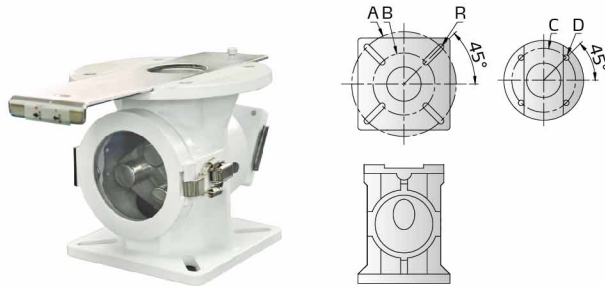

Air exhaust Filter



It can effectively filter the dust air discharged from the dryer to avoid air contamination, and the efficiency reaches 99%.

Model	Applied to	mount size				
		A	B	C	D	R
MB-12EB	SHD-12E	-	-	Ø104	4×Ø9EQS	-
MB-50	SHD-25E-75E	-	-	Ø140	4×Ø9EQS	-
MB-100EB	SHD-100E/150E	Ø213	Ø126	Ø190	4×Ø12EQS	6
MB-200EB	SHD-200E/300E	-	-	Ø255	4×Ø14EQS	-
MB-400EB	SHD-400E/500E	-	-	Ø255	4×Ø16EQS	-
MB-600EB	SHD-600E	-	-	Ø255	4×Ø16EQS	-

Model	Applied to	mount size	
		A	B
ADC-1	SHD-12E	Ø65	4×Ø7EQS
ADC-2EB	SHD-25E-150E	Ø95	4×M6EQS
ADC-3EB	SHD-200E-500E	Ø120	4×M6EQS
ADC-3	SHD-600E	Ø160	4×Ø6.5EQS

Hot Air Recycler

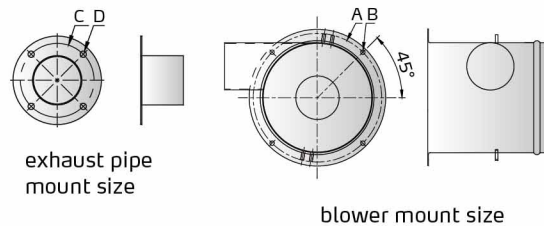

exhaust pipe
mount size

blower mount size

Work with hopper dryer to make the hot air form a semi-closed circulated loop and has features as follows:

- 1) Hot air recycling and circulating avoids indoor temperature rising up.
- 2) Keep air in factory clean and ensure good product quality.
- 3) The energy consumption can be reduced by fast heating speed of the hot air circulation, which saves 40% of the energy.

Model	Filtering Barrel Dia. (mm)	Inlet Air Pipe Dia. (inch)	Flange of Air Outlet (inch)	Applied to	mount size			
					A	B	C	D
HAR-12	157		2	SHD-12E	Ø165	4×Ø7EQS	Ø65	4×Ø7EQS
HAR-25EB	157		2.5	SHD-25E	Ø207	4×Ø6EQS	Ø95	4×Ø7.5EQS
HAR-50	177		3	SHD-50E/75E	Ø207	4×Ø7EQS	Ø95	4×Ø7.5EQS
HAR-100EB	219		3	SHD-100E/150E	Ø207	4×Ø7EQS	Ø95	4×Ø7.5EQS
HAR-200EB	249		4	SHD-200E/300E	Ø255	6×Ø6EQS	Ø120	4×Ø8EQS
HAR-400EB	221		4	SHD-400E/500E	Ø255	6×Ø7EQS	Ø120	4×Ø8EQS
HAR-600EB	221		4	SHD-600E	Ø292	6×Ø7EQS	Ø160	4×Ø8EQS

Blower Inlet Filter

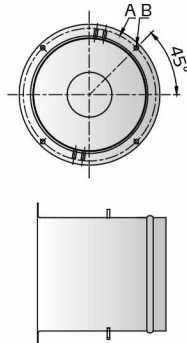

Model	Filtering Barrel Dia. (mm)	Overall height (mm)	Applied to	mount size	
				A	B
AIF-12	157/6.2"	195/7.7"	SHD-12E	Ø165	4×Ø7EQS
AIF-25EB	157/6.2"	195/7.7"	SHD-25E	Ø207	4×Ø6EQS
AIF-50	177/7.0"	201/7.9"	SHD-50E/75E	Ø207	4×Ø7EQS
AIF-100EB	219/8.6"	191/7.5"	SHD-100E/150E	Ø207	4×Ø7EQS
AIF-200EB	249/9.8"	268/10.6"	SHD-200E/300E	Ø255	6×Ø6EQS
AIF-400EB	221/9.0"	380/15.0"	SHD-400E/500E	Ø255	6×Ø7EQS
AIF-600EB	221/9.0"	380/15.0"	SHD-600E	Ø292	6×Ø7EQS

Notes: refill air input of the blower is adjustable.

Hopper Magnet



Model	Applied to	Aluminum Holder×2(mm)
MR-5	SHD-12E	(148×80×2.3)
MR-7	SHD-25E\50E\75E	(190×80×2.3)
MR-9	SHD-100E\150E\200E\300E\400E\500E	(240×80×2.3)
MR-11	SHD-600E	(290×80×2.3)

Material Suction Box/Shut-off Suction Box



Model	Applied to	SHD-12EB-75EB	SHD-100EB-400EB
SBU		-20-38S	-160-38S
SBU		-20-50S	-160-50S
SBU		-20-38S	-160-38D
SBU		-20-50S	-160-50D

- Notes: 1) Install pneumatic shut off valve (add "V" at the end of the model code).
 2) Change into stainless steel material (add "S" at the end of the model code).
 3) Stainless steel polishing (add "P" at the end of the model code).
 4) "S" stands for single tube suction box and "D" stands for double tubes suction box.
 5) It needs to work with the floor stand.

Outline Drawings

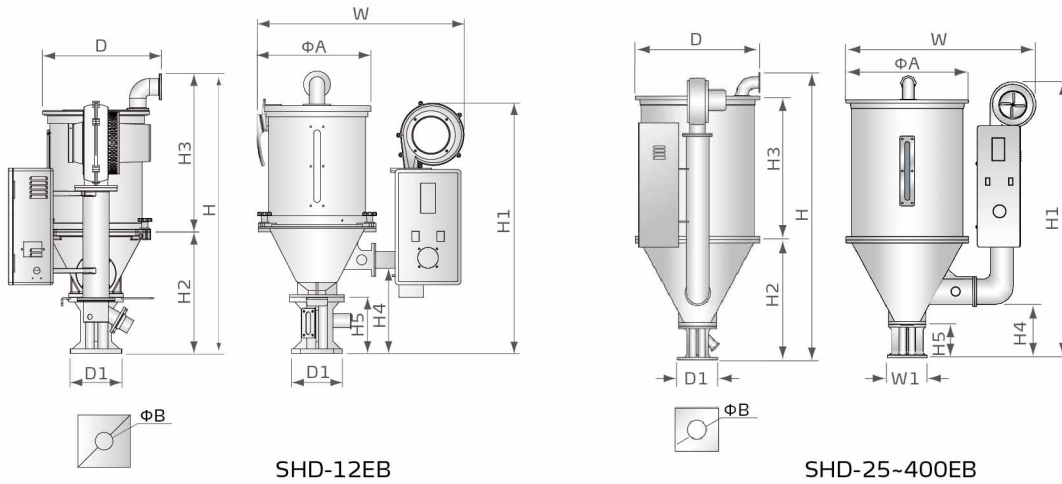

SHD-12EB

SHD-25~400EB

Specifications

Model SHD-	12EB	25EB	50EB	75EB	100EB	150EB	200EB	300EB	400EB	500EB	600EB
Drying heater (kw)	2.2/3*	3/3.3*	3.9/4.2*	4.2/4.8	6/6.6*	6.6/7.2*	8.4/9.6*	9.6	18	19.5	21
Blower(w)	100	155	155	155	215	215	350	350	450	450	1030
Loading Capacity(kg)	12	25	50	75	100	150	200	300	400	500	600
H (mm)	825	1015	1145	1445	1330	1650	1730	2180	1940	2480	2170
H1 (mm)	810	925	1045	1045	1360	1360	1590	1590	1760	1760	2080
H2 (mm)	325	410	380	380	535	535	635	635	710	710	815
H3 (mm)	380	460	520	820	650	970	920	1370	1040	1040	1335
H4 (mm)	160	194	206	206	313	313	338	338	435	435	344
H5 (mm)	110	150	150	150	175	175	195	195	205	205	245
W (mm)	670	725	840	840	1020	1020	1210	1210	1400	1400	1560
D (mm)	350	405	490	490	640	640	780	780	920	920	1033
D1 (mm)	110	158	158	158	180	180	230	230	280	280	280
W1 (mm)	110	158	158	158	180	180	230	230	280	280	280
ΦA (mm)	330	385	470	470	600	600	750	750	910	910	1050
ΦB (mm)	45	53	53	53	85	85	110	110	120	120	120
Weight(kg)	25	28	31	38	49	52	70	84	115	115	115

- Notes
- 1) Above loading capacity is based on particles of 0.65kg/L(5.5lb/gal) bulk density in diameter of 3-5mm (0.1-0.2 inch).
 - 2) "*"High-temp. model option up to max. 180°C.
 - 3)The max. temp. of SHD-EB-EH is 150°C.
 - 4)Power: 3 Φ, 400VAC, 50HZ.

We reserve the right to change specifications without prior notice.