



## "Budget" Series SG-EB

SG-2130EB



Refer carefully to this manual before operation.

# SG-EB Series

## ■ Coding Principle

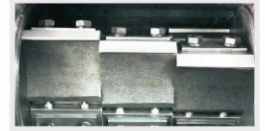
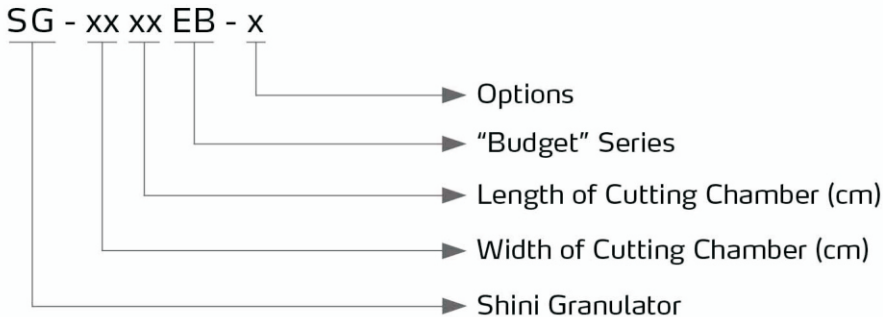

Staggered Cutter

## ■ Features

- Staggered blades design can decentralize working load when granulating to increase cutting efficiency. (SG-60110EB adopts paddle-blade structure.)
- Cutters adjustment are available. Shaping after blunt ensures longer life service.
- Adopt adjustable bearing with base, mounted outside of cutting chamber's side plate of bearing for convenient installation and maintenance.
- Optimal design can effectively reduce vibration during operation of granulator.
- Equipped with motor overload relay and multiple safety devices to ensure machine safe operation.
- SG-3260EB and the models below are equipped with castor wheels. They have small footprint and are easy to move.



SG-4880EB

## ■ Application

The granulators are applicable to granulate various kinds of plastic materials from injection molding, blow molding or wasted materials.

## ■ Options

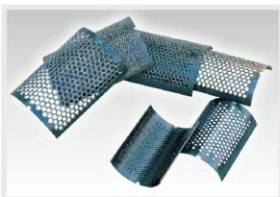

### Special Screen

Φ6, Φ10, Φ12 and Φ16 are special diameters of screen, being able to meet different production demands. Φ10, Φ14 and Φ16 are optional for SG-4880&SG-60110EB, add "SS + screen diameter" at the end of the model code, e.g.: Φ8mm, add "SS08".

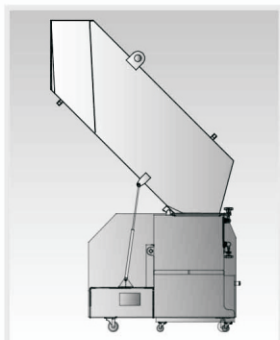

### Direct feed box

As to meet customer's demands on cutting strip thin-wall scraps (e.g. thin-walled strip automobile products), the direct feed box is optional for SG-3260EB, add "DF" at the end of the model code.

- For Fiber Reinforced materials, full fiber reinforced model is optional. Adopt surface-hardening treatment on the material contacting components blade material is V-4E joint with S50C, add "F" at the end of the model code.
- Feed port and storage tank are made of stainless steel, add "R" at the end of the model code.

## Outline Drawings

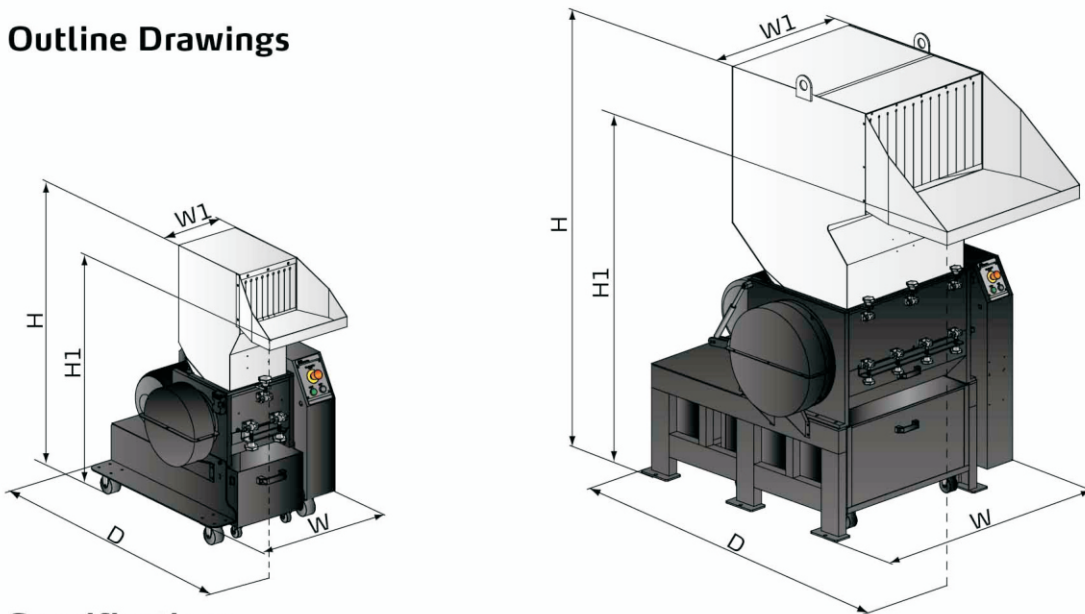

## Specifications

Model		SG-2130EB	SG-2540EB	SG-2950EB	SG-3260EB	SG-4880EB	SG-60110EB	
Motor Power		5.5	7.5	11	15	22	30	
Rotating Speed (rpm, 50/60Hz)		540	540	540	450	525	525	
Material of Blades		Cr12Mo1V1	Cr12Mo1V1	Cr12Mo1V1	Cr12Mo1V1	Cr12Mo1V1	Cr12Mo1V1	
Blade Type		Staggered	Staggered	Staggered	Staggered	Staggered	Paddle	
Quantity of Fixed Blades		2	2	2	4	4	4	
Quantity of Rotating Blades		3 × 3	3 × 4	3 × 5	3 × 6	3 × 8	3 × 2	
Cutting Chamber	mm	210 × 300	250 × 400	290 × 500	320 × 600	480 × 800	600 × 1100	
	inch	8.3 × 11.8	9.8 × 15.7	11.4 × 19.7	12.6 × 23.6	18.9 × 31.5	23.6 × 43.3	
Max. Output	kg/hr	150~200	200~250	250~300	300~350	450~600	700~1000	
	lb/hr	331~441	441~551	551~661	661~772	992~1323	1543~2205	
Noise Level dB(A)		105~ 110	105~ 110	105~ 110	105~ 110	105~110	110~115	
Screen Dia.	mm	√(Φ8)	√(Φ8)	√(Φ8)	√(Φ8)	√(Φ12)	√(Φ12)	
	inch	√(Φ0.3)	√(Φ0.3)	√(Φ0.3)	√(Φ0.3)	√(Φ0.47)	√(Φ0.47)	
Flywheel		√	√	√	√	√	√	
Dimension	H	mm	1200	1385	1450	1600	2320	2758
		inch	47.2	54.5	57	63	91.3	108.6
	H1	mm	1008	1156	1173	1293	1725	2200
		inch	39.7	45.5	46.2	50.9	67.9	86.6
	W	mm	694	795	904	1029	1302	1670
		inch	27.3	31.3	35.6	40.5	51.3	65.7
	W1	mm	300	400	500	600	800	1100
		inch	11.8	15.7	19.7	23.6	31.5	43.3
	D	mm	1105	1330	1430	1515	2049	2472
		inch	43.5	52.4	56.3	59.6	80.7	97.3
Weight	kg	400	470	550	720	1600	2000	
	lb	882	1,036	1,213	1,587	3,527	4,409	

Notes: 1) "√" stands for standard.

2) Cr12Mo1V1 is corresponding to SKD11 under Japanese JIS standard.

3) When granulating fibers reinforced plastics or materials alike (e.g. CPVC), it is suitable to select granulators with special quenching process in for cutting chamber and blades, and also add "F" at end of the model code.

4) Max. capacity of the machine is subject to diameter of screen mesh and composition of material.

5) Noise level varies with different materials and motor types.

6) To avoid plastic from sticking to the blades, all materials should be crushed at normal temperature.

7) Power supply : 3Φ, 230/400/460/575VAC, 50/60Hz.

We reserve the right to change specifications without prior notice.