



## Declined Belt Conveyor

SC-300W-2000L



Refer carefully to this manual before operation.

## ■ Coding Principle

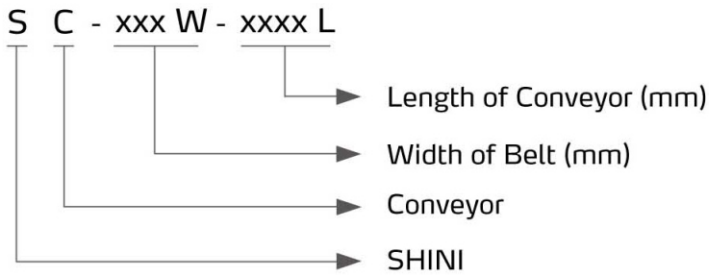

## ■ Features

- Employs high precision aluminum alloy profile, anodization of sand blast, elegant appearance.
- The belt is made of high quality PVC material, improve the appearance and wearable.
- The height can be easily adjusted by using hand wheels.
- Universal casters work with brake casters, fixed or movable as ease.
- Control speed though knob speed governor, easily and conveniently.
- With automatic and manual function, can working with robot or independently.

## ■ Application

The SC Series declined belt conveyor is designed for delivery products after robot picks them out from injection molding machine. The signals connect with robot achieves full automatic operation, improve the production efficiency and protect products.

# SC Series

## Outline Drawings

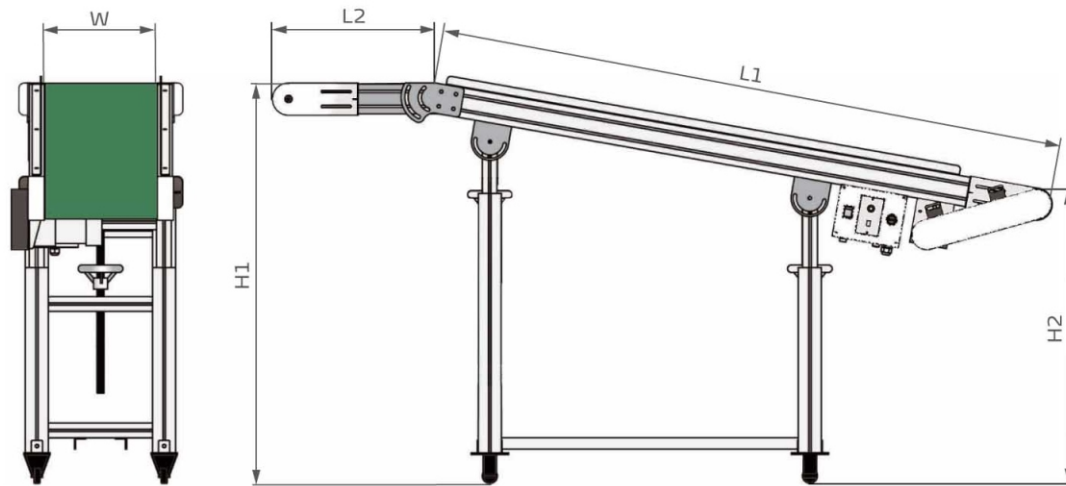

## Specifications

Model	SC - 200W	SC - 300W	SC - 400W	SC - 500W	SC - 600W
Width of Belt W (mm)	200	300	400	500	600
Length of Horizontal Plane L2 (mm)	400 / 600 / 800				
Total Length L1+L2 (mm)	2000 / 3000 / 4000 / 6000				
Height of Higher End H1 (mm)	1000 ~ 1600				
Height of Lower End H2 (mm)	700 ~ 1000				
Max Load (with tool) (kg)	20 (Uniform)				
Max Speed (m/min)	12				
Belt Description	Material: PVC / Thickness: 2mm / Color: Green Rating of Temperature: -10°C~+80°C / Static-free, ard Wearing, Oil proof				
Power Source	AC220V ± 10V 50/60Hz				
Motor Rated Power (W)	60				

We reserve the right to change specifications without prior notice.

## Shini Group

Addr: No. 23, Minhe St., Shulin Dist.,  
New Taipei, Taiwan

Tel: +886 2 2680 9119

Fax: +886 2 2680 9229

Email: [shini@shini.com](mailto:shini@shini.com)

### Factories:

- Taiwan
- Dongguan
- Pinghu
- Ningbo
- Mumbai

2013-09-15-04 Copyrights Reserved.

[www.shini.com](http://www.shini.com)