



Dehumidifying Dryer

SDD-80U/40H



Refer carefully to this manual before operation.

SDD Series

■ Coding Principle

SDD-xxxU/xxxH-xxx

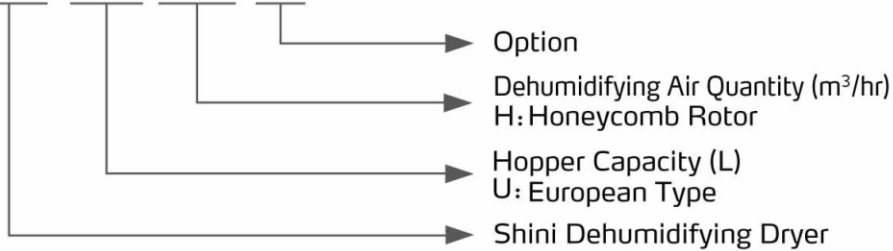

■ Features

- TAdopt molecular sieve structure honeycomb, which provides low dew-point dry air and is superior to double-barrel dehumidifier that will contaminate raw material due to damaged molecular sieve.
- Dehumidifying and drying function are integrated to ensure high efficiency.
- Insulated drying hopper features dry air down-blowing and cyclone exhaust design. This improves drying efficiency and reduces heat loss, saving energy.
- The dehumidifying section of the SDD series adopt cooler to ensure a low return air temperature and low dew-point.
- Microprocessor is the standard equipment, with a temperature controlling accuracy of $\pm 1^{\circ}\text{C}$.
- Equipped with weekly timer, machine can automatically operate.



Control Panel

■ Application

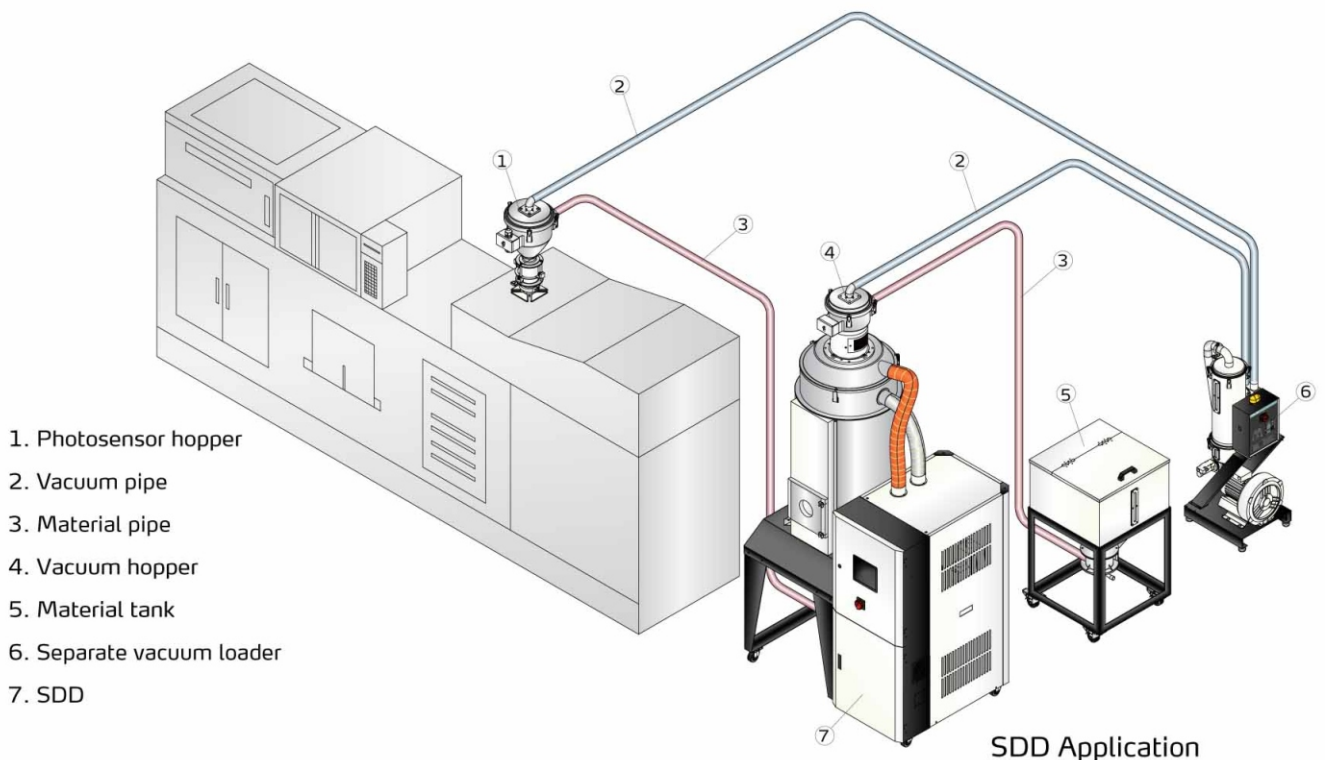

Working Principle

Damp and hot air from dry material barrel is blown into rotor after cooled. Moisture from the air is absorbed by rotor and is then adsorbed by regeneration heating air. Two strands of airflow function on the rotor. And with the rotation, moisture from the air is absorbed and expelled after absorbed regeneration air to form stable low dew-point air, which is dried to the drying temperature and then is blown into material barrel to closed circle to dry material.

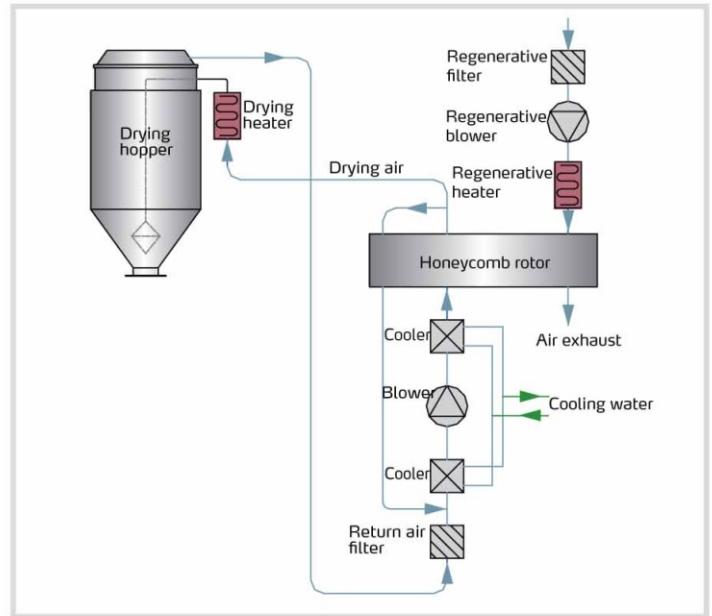

Outline Drawings

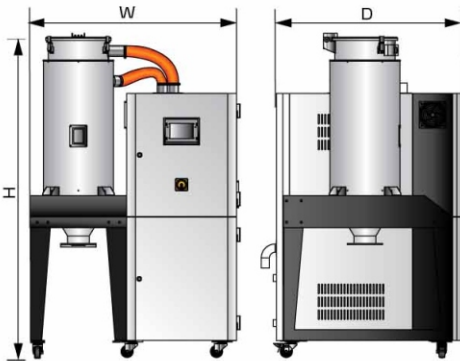

SDD-40U/40H-230U/120H



SDD-300U/200H-1200U/700H

Specifications

Model	40U/40H	80U/40H	120U/80H	160U/80H	160U/120H	230U/120H	300U/200H	450U/200H	600U/400H	750U/400H	900U/700H	1200U/700H		
Regen. Heater (kW)	3			4			7.2		10					
Regen. Blower (kW, 50/60Hz)	0.12		0.4			0.75		1.5		7.5				
Drying Heater (kW)	4			6			12		18		24			
Drying Blower (kW, 50/60Hz)	0.12		0.75			1.5		3.75		7.5				
Dry Air Volume (m ³ /hr)	40		80			120		200		400		700		
Insulated Hopper	L	40	80	120	160	230	300	450	600	750	900	1200		
	gal	10.6	21	31.7	42.3	60.8	79.3	119	158.5	198	238	317		
Dimension	H	mm	1509	1796	1817	1740	2070	2052	2040	2440	2380	2610	2640	3070
		inch	59.4	70.7	71.5	68.5	81.5	80.8	80.3	96	93.7	102.8	104	121
	W	mm	978	1060	1061	1220	1061	1210	1450	1745	2140			
		inch	38.5	41.7	41.8	48	41.8	47.6	57	68.7	84.3			
D	mm	931	1030	893			1050	1255	1380					
	inch	36.7	40.6	35.2			41.3	49.4	54.3					
Weight	kg	165	190	250	255	265	295	420	550	620	650	830	870	
	lb	364	419	551	562	584	650	926	1213	1367	1433	1830	1918	

Notes: 1) Plastic materials can be fully dried by drying air with dew-point temperature $\leq -20^{\circ}\text{C}$.
2) Power: 3 Φ , 230/400/460/575VAC, 50/60Hz.