



Vertical Batch Mixer

SVM-300U



Refer carefully to this manual before operation.

SVM-U Series

■ Coding Principle

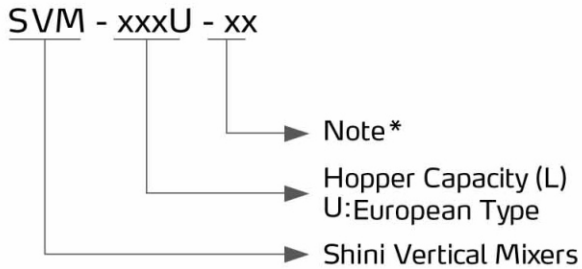

■ Features

- Vertically mounted blending screw and cylinder ensure even mixing of materials.
- Removable top assembly (lid, motor, and control box) for easy cleaning.
- Function of feeding plus mixing simultaneously can save time significantly.
- 0~30 min auto-stop function.
- Equipped with main power switch and safety interlock protective device to ensure operator's safety and no damage to the machine.

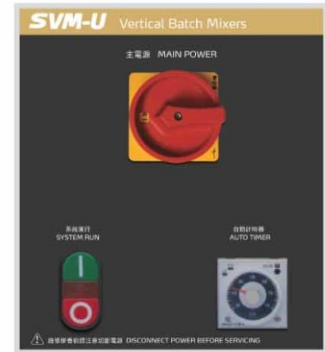

Control Panel

■ Options

- Rotary level sensor is optional. Add "HL" at the end of model code.
- For SVM-1000U and above models optional with the heating function, add "HA" at the end of the model code.

■ Application

SVM-U is mainly used for mixing plastics as raw materials, masterbatch and recycled materials. SVM-U can not be used dealing with plastic powder and all kinds of foods, chemicals, and inflammable, explosive and volatile materials. Bulk density should be taken into account when the dimension of material is uneven or in other forms.

■ Working Principle

To achieve the aim of mixing material, screw blades are used to generate vortex. Materials are sucked towards mixing screws at the center of hopper bottom by vortex, then materials whirl upward to the top and fall down so that the evenly mixing can be fulfilled in a short period.

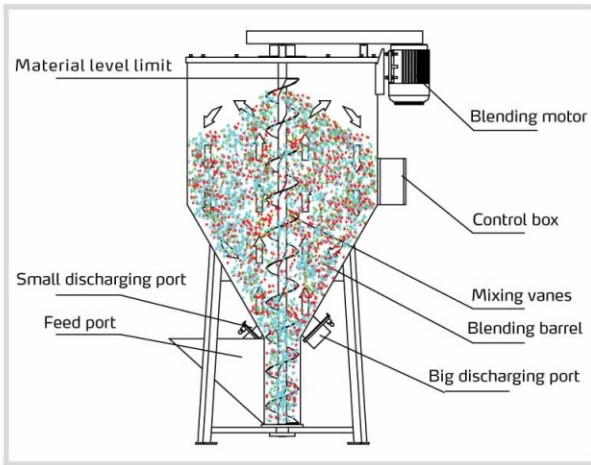

Signals from the control cabinet is sent to blending motor which drives the blending screw to start material blending. Then material are conveyed along the cylinder up to the top is evenly spread in the blending barrel. This process mixes material evenly in a short time and saves energy. After blending, pull open the shut-off plate to discharge the material.

Outline Drawings

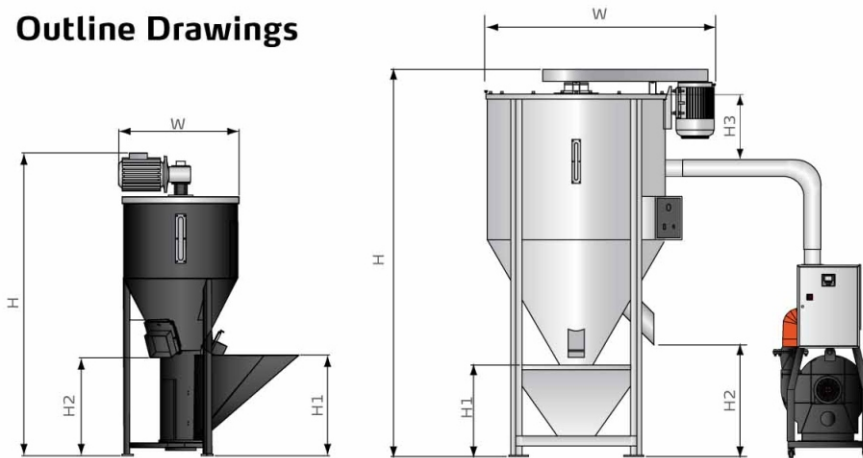

SVM-300U and below

SVM-1000U(-HA) and above

Model	Pipe diameter (inck)	H3 (mm)
SVM-1000U-HA-700	4	860
SVM-2000U-HA-1000	5	875
SVM-3000U-HA-1500	6	885
SVM-4000U-HA-2000	8	915
SVM-6000U-HA-3000	8	915
SVM-10000U-HA-4000	10	1600

Specifications

Model		SVM-160U	SVM-300U	SVM-1000U	SVM-2000U	SVM-3000U	SVM-4000U	SVM-6000U	SVM-10000U	
Motor Power (kW,50/60Hz)		1.1	1.1	4	5.5	5.5	5.5	7.5	11	
Max. Throughput	kg/hr	400	800	2600	3900	5800	7800	9750	13000	
	lb/hr	882	1764	5732	8598	12787	17196	21495	28660	
Blending Barrel*	L	160	300	1000	2000	3000	4000	6000	10000	
	gal	42	79	264	529	793	1057	1585	2642	
Dimensions	H	mm	1620	1700	2600	2850	3200	3200	3800	4300
		inch	63.8	67	102	112.2	126	126	149.6	169.3
	H1 (mm)	mm	553	583	710	720	770	770	710	780
		inch	21.8	23	28	28.3	30.3	30.3	30.3	30.7
	H2 (mm)	mm	557	528	650	650	650	650	650	650
		inch	21.9	20.8	25.6	25.6	25.6	25.6	25.6	25.6
W (mm)	mm	955	1050	1200	1550	1680	1880	2050	2350	
	inch	37.6	41.3	47.2	61	66	74	80.7	92.5	
Weight	kg	150	200	455	750	890	1000	1270	1700	
	lb	331	441	1003	1653	1962	2205	2800	3748	

Notes: 1) Max. noise level is 70dB (A).

2) Max. mixing capacity is tested based on continuous processing material of 0.65kg/L(5.5lb/gal) in bulk density and 2~3mm/0.08~0.12inch in size.

3) Power 3 Φ , 230 / 400 / 460 / 575VAC, 50 / 60Hz.

We reserve the right to change specifications without prior notice.

Shini Group

Addr: No. 23, Minhe St., Shulin Dist.,
New Taipei, Taiwan

Tel: +886 2 2680 9119

Fax: +886 2 2680 9229

Email: shini@shini.com

Factories:

- Taiwan
- Dongguan
- Pinghu
- Ningbo
- Chongqing
- Pune