



## "Budget" Series Heater

STM-607-EB



Refer carefully to this manual before operation.

# STM-EB Series

## ■ Coding Principle

STM- xxxx(W) - EB - XX

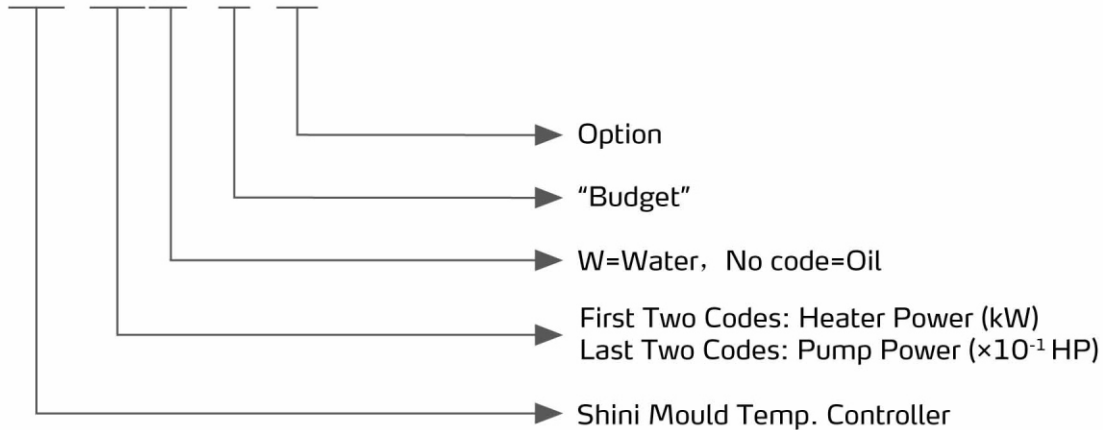

## ■ Features

- Full digital P.I.D. temp. control system maintains stable mould temp. with control accuracy up to  $\pm 0.5^{\circ}\text{C}$ .
- High-efficiency high temp. pump achieves the high efficiency heat exchange.
- Equipped with power phase reverse protector, pump overload protector and overheat protector and other safety devices, the machine can automatically detect the abnormalities with indicator lights when failure occurs.
- STM-W-EB is equipped with the low level protector.
- STM-W-EB is equipped with high pressure release valve to ensure the system safety.

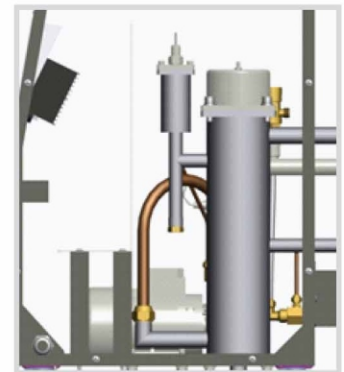

STM-W-EB Inner Structure

## ■ Options

Water manifolds, Teflon hose and transfer oil are optional.

## ■ Application

STM-EB series are applicable for heating up moulds and maintaining temperature, and they also can be used in other similar applications. Firstly, these series adopt different cooling methods to cool down media, then media are conveyed to the moulds after pressurized by pump and heated up by electrical heated tube. As medium, the water could reach  $120^{\circ}\text{C}/248^{\circ}\text{F}$  and oil could reach  $200^{\circ}\text{C}/392^{\circ}\text{F}$ .

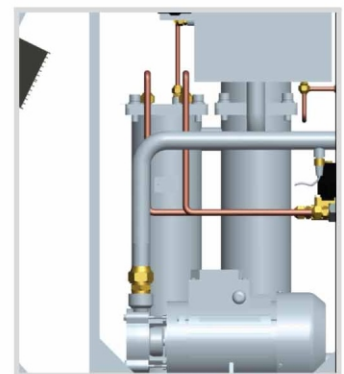

STM-EB Inner Structure

## Working Principle

The high temperature oil returns to the heater through pipe and then be pressured by pump to mold after being heated. This cycle repeats. In the process, if the temp. is too high, the system will activate the solenoid valve to let cooling water lower the temperature indirectly until the it reaches the system requirement. If the temperature keeps increasing and reaches the set point of EGO, the system will alarm and stop operation. The system will sound low level alarm and stop working if oil level falls down below the set point.

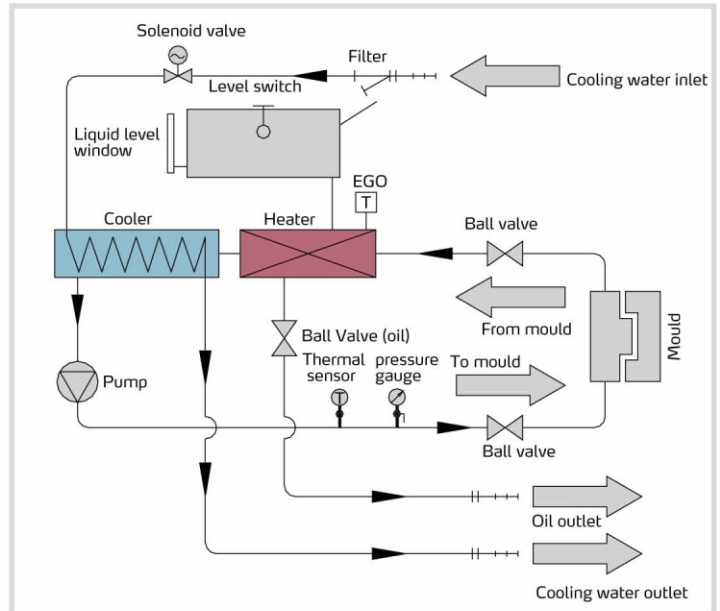

System Flow for STM-EB (Indirect Cooling)

The water in the heating tank is delivered to the mould by pump after it is headed, and then return to the heating tank after it heats up the mould, and so on. In the circulation, if the water temp. is too high, it will be sent to the control system via the temp. sensor, and then the system will activate the solenoid valve. The cold water enters the system for cooling, and the solenoid valve will close once the cooling water temp. reaches the set valve, thus achieving the constant purpose of the whole circulation. If the temp. exceeds the limit of the temp. protector (snap action temp. controller), the system will alarm and halt. When system pressure is too high, the safety valve will open as to release the pressure as to ensure the safety. If the water is lost during the process, the water level in this system will decrease. When the level sensor detects the decreased water level, the system will open the solenoid valve to refill the water. When the level sensor detects the water level, the solenoid valve will close to prevent heating up without water.

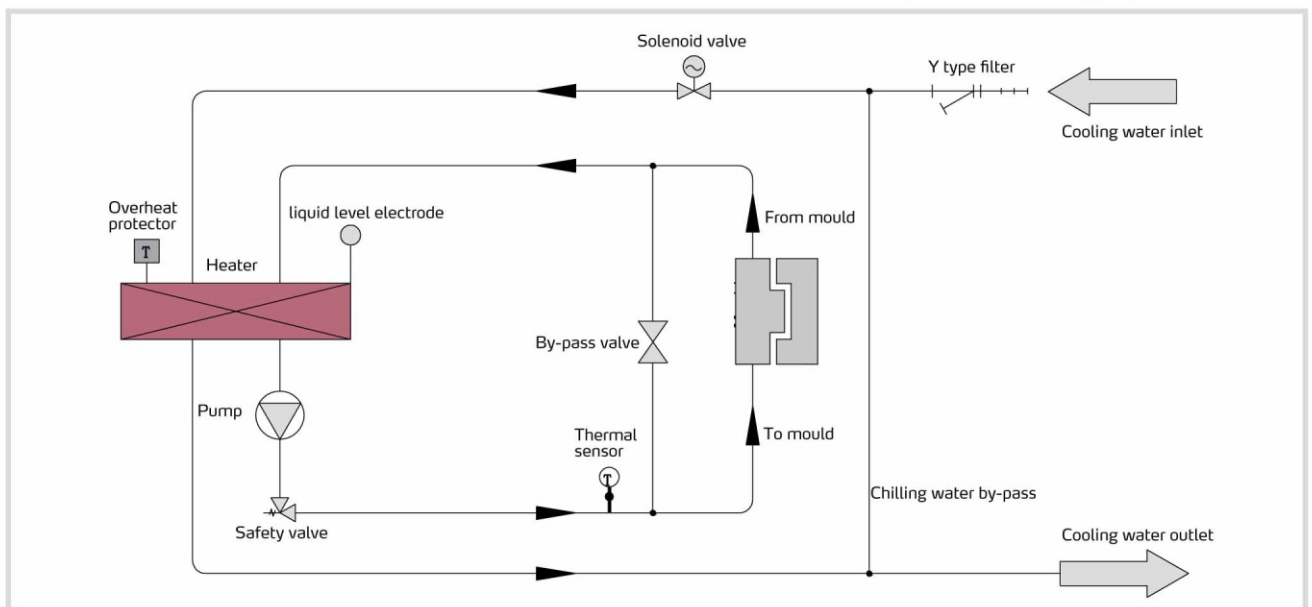

System Flow for STM-607W-EB (Direct Cooling)

# STM-EB Series

## Specifications

Model		STM-607-EB	STM-607W-EB	STM-910-EB	STM-910W-EB	STM-1220-EB	STM-1120W-EB
Max. Temp.		200°C/392 °F	120°C/248°F	200°C/392 °F	120°C/248°F	200°C/392 °F	120°C/248°F
Pipe Heater (kW)		6		9		12	
Pump Power (kW)		0.55		0.75		1.5	
Max. pump Flow	L/min	27		42		74	
	gal/min	7.1		11		19.5	
Max. pump Pressure (bar)		3.8		5.0		6.2	
Heating Tank Quantity		1		1		1	
Main/Sub. Oil Tank	L	6.0 / 3.3	-	6.0 / 3.2	-	6.8 / 11.8	-
	gal	1.6 / 0.9	-	1.6 / 0.8	-	1.6 / 3.1	-
Water Heating Tank Capacity	L	-	2.0	-	3.0	-	3.0
	gal	-	0.53	-	0.8	-	0.8
Cooling Method		Indirect	Direct	Indirect	Direct	Indirect	Direct
Inlet/Outlet(inch)		3/4 / 3/4		3/4 / 3/4		1/1	
Dimensions (H × W × D)	mm	686×325×563	575×285×505	705×365×655	670×305×620	705×365×700	665×320×635
	inch	27×12.7×22.2	22.4×11.1×19.7	27.8×14.4×25.8	26.4×12×24.4	27.8×14.4×27.6	26.2×12.6×25
Weight	kg	49	38	70	60	80	75
	lb	108	83.8	154	132	176	165

- Notes: 1) Pump testing standard: Power of 50/60Hz, purified water at 20°C/68°F.  
(There is ±10% deviation for both max. flow rate and max. pressure).  
2) "\*" stands for options.  
3) Power supply: 3Φ, 230/400/460/575VAC, 50/60Hz.

## Pump Performance Curve

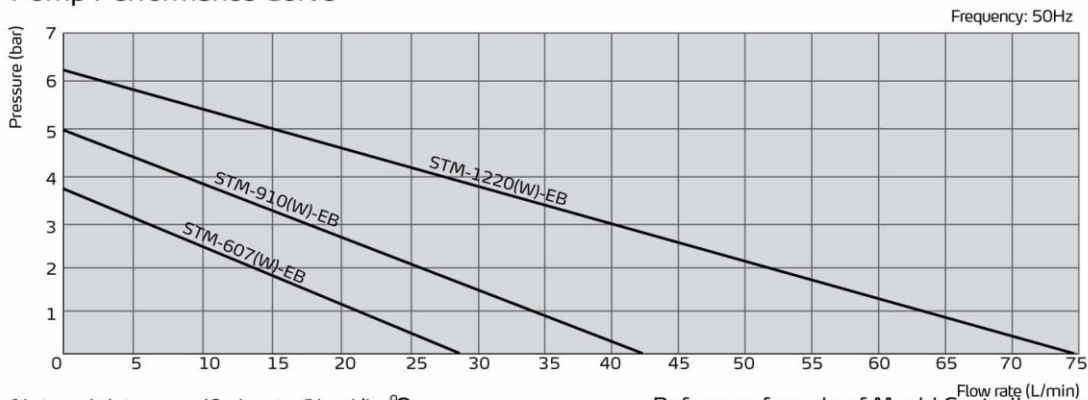

- Notes: Water specific heat =1kcal/kg°C  
Heating medium oil specific heat =0.49kcal/kg°C  
Water density =1kg/L  
Heating medium oil density =0.842kg/L  
Time for heating=the time needed to heat from room temperature to set temperature

Reference formula of Mould Controllers model selection

Heater Power (kW) = mould weight (kg) × mould specific heat (kcal/kg°C) × temperature difference between mould and environment (°C) × safety coefficient / heating duration / 860

Notes: Safety coefficient range 1.3~1.5.

Flow Rate (L/min) = heater power (kW) × 860 / [(heating medium specific (kcal/kg°C) × heating medium density (kg/L) × in/outlet temperature difference (°C) × time (60)]