



"Budget" Series SG-18EB

SG-1830EB



Refer carefully to this manual before operation.

SG-EB Series

■ Coding Principle

SG - xx xx EB - x

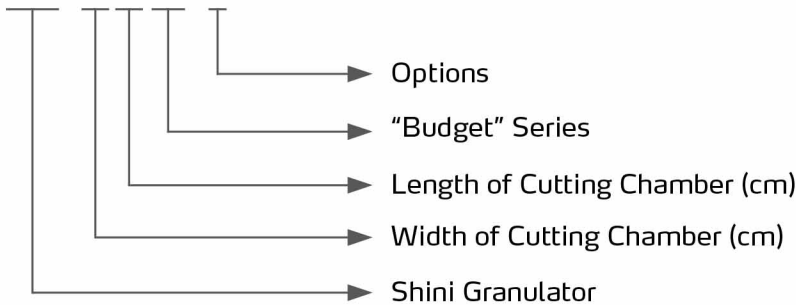

■ Features

- Staggered blade design increase cutting efficiency. Cutters re-adjustments are available. It can be resharpener when it is blunt to ensures a longer life span.
- Adjustable bearing and holder. it is mounted on the out-sides of the cutting chamber is side plate for convenient installation and maintenance.
- The optimal cutting angle reduces resistance and avoids blockage, which improves cutting efficiency.
- The symmetry design can effectively reduce vibration during the operation of the granulator.
- It is equipped with a motor overload relay and multiple safety devices to ensure the unit runs safely and smoothly.
- The unit is portable and takes a small footprint.

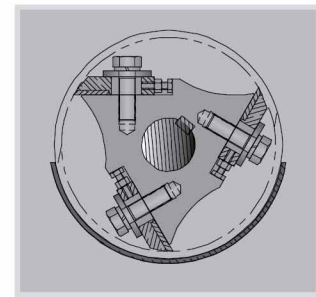

Cutting Chamber

■ Application

The granulators are suitable to granulate various kinds of small rejected plastic materials from injection molding, blow, blow molding....etc.

■ Options

Special Screens

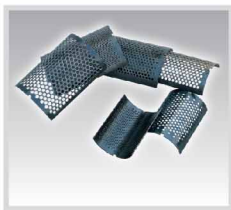

Special screen mesh sizes: $\Phi 8$, $\Phi 10$, $\Phi 12$, $\Phi 16$ (mm).

Add "SS + screen diameter" at the end of the model code, e.g.: $\Phi 8$ mm, add "SS08".

- To filter thin materials, a screen with slanting holes is optional. Add "SH05" at the end of the model code.
- Optional Blower feeding (BC type)

30-Sec Instant Recycling System

The 30-Sec Instant Recycling System utilize compressed air to convey the regrind material form the storage box to the neckpiece for immediate result of material. AS a result, it can reduce regrind form regining too much moisture, improving the overall quality of end products, and zero material waste.

Add "BR" at the end of the model code.

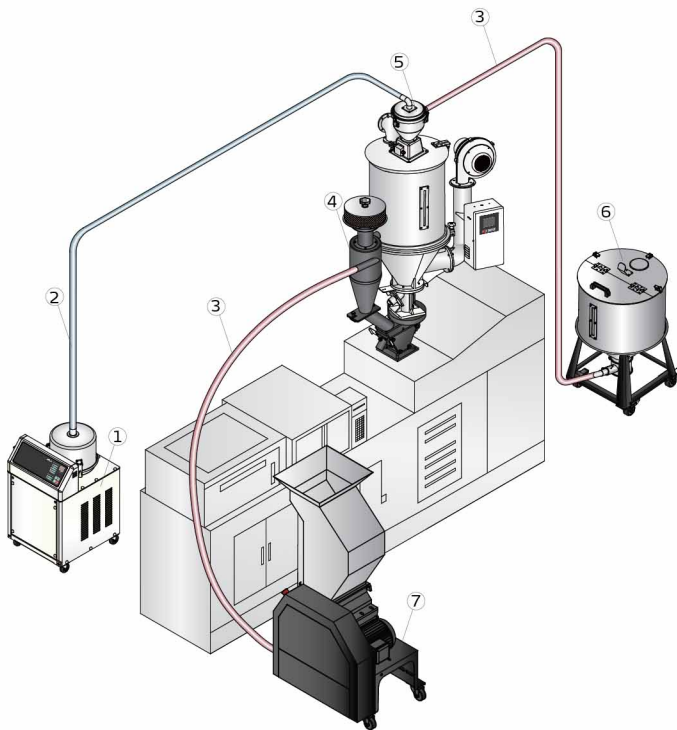

1. Autoloader main unit
2. Vacuum pipe
3. Material pipe
4. 30-Sec instant recycling system
5. Hopper receiver
6. Material tank
7. SG-1830EB

BR Type 30-Sec Instant Recycling

Outline Drawings

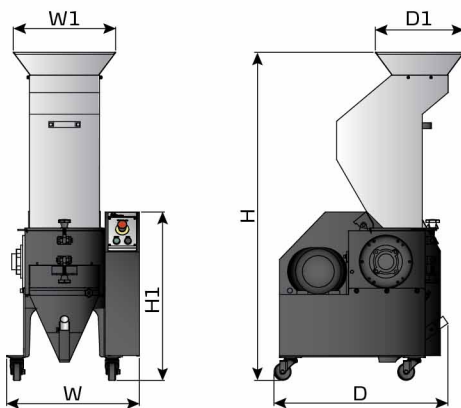

SG-1830EB

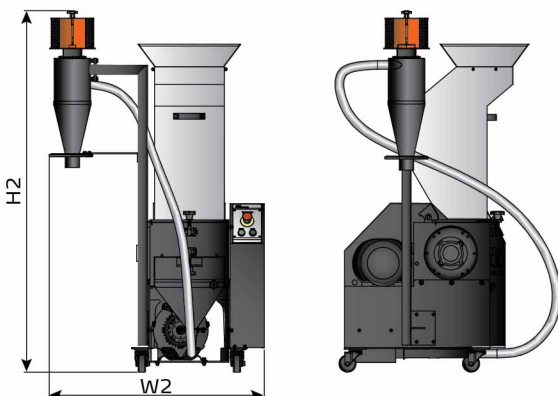

Optional blower conveying + cyclone dust collector (BC type)

Specifications

Model	SG-1830EB		
Motor Power (kW, 50/60Hz)	1.5/1.72		
Rotating Speed (rpm, 50/60Hz)	230/278		
Material of blade	Cr12Mo1V1		
Blade type	Staggered		
Quantity of Fixed Blades	2		
Quantity of Rotating Blades	3 x 3		
Cutting Chamber (mm)	180 x 300		
Max. Output (kg/hr)	50		
Noise Level dB(A)	≤90		
Screens (mm)	φ6		
Dimensions	H	1441mm	56.7"
	H1	740mm	29.1"
	H2	1587mm	62.5"
	W	583mm	23"
	W1	450mm	17.7"
	W2	944mm	37.2"
	D	764mm	30"
	D1	390mm	15.4"
Weight	150kg	331lb	

- Note: 1) Cr12Mo1V1 is corresponding to SKD11 under Japanese JIS standard .
 2) Max. Capacity of the machine is subject to the size and composition of the material.
 3) Noise level varies according to different granules.
 4) To avoid plastic from sticking to the blades, all materials should be crushed at normal temperature.
 5) Power supply: 3Φ, 230/400/460/575VAC, 50/60Hz.

Shini Group

Addr: No. 23, Minhe St., Shulin Dist.,
New Taipei, Taiwan

Tel: +886 2 2680 9119

Fax: +886 2 2680 9229

Email: shini@shini.com

Factories:

- Taiwan
- Dongguan
- Pinghu
- Ningbo
- Chongqing
- Pune

2021-06-15-04 Copyrights Reserved.

www.shini.com