



Three Axes Servo Driven Robot



ST3-700-1400



Refer carefully to the Manual before using products.



■ Coding Principle

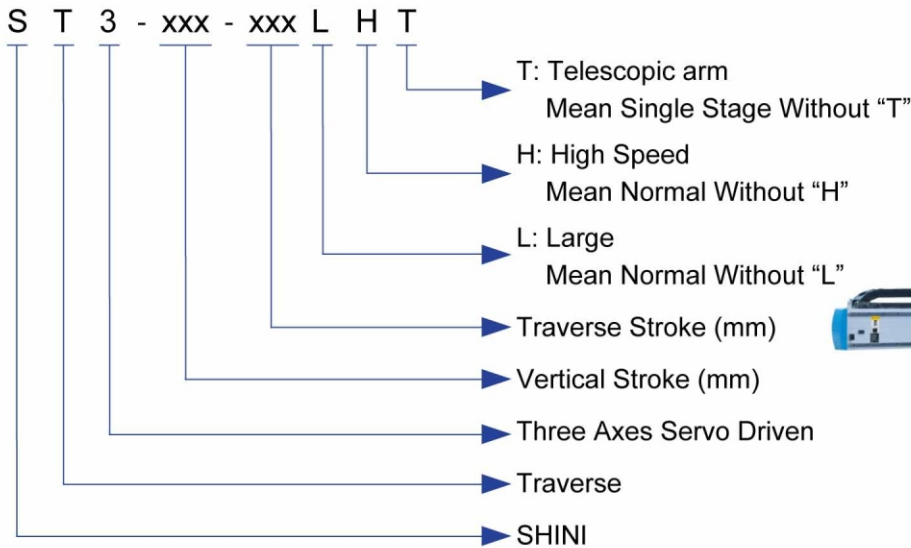

ST3-700-1400T

■ Features

● Appearance

Designed with elegant appearance; Aluminium profiles are largely used to provide compact and streamlined appearance.

● Precision

All linear movements are driven by heavy duty servo motors with cooperation of precise linear guide rails and high power V belts; Fast, silent, and precise. Wrist mechanism employs pneumatic driven rack and pinion system, which accomplishes smooth, stable and precise flipping motion. Vertical arm with telescopic design efficiently minimizes the cycle time and height of the robot.

● Safety

Position limit sensors and blocks effectively prevent mechanical and electrical malfunctions. Control board is designed to CE EMC test with short circuit and noise proof functions.

● Convenience

Control hardware fixtures are designed with flyer structure which provides benefit to maintenance. Cable drag chains help with cable management and ease for maintenance.



ST3-2600-2800LT



Control Panel

- Standardization

All pneumatic accessories, electric accessories, and communication Protocols meet the global standards. Interface between injection molding machine and robot is designed to EUROMAP 12, EUROMAP 67 and SPI.

- Intelligence

Base on VARAN BUS technology with world class 8.4 inch true color touch screen and object oriented program editor, complex and continuous projection can be easily programmed within minimum time. Closed circuit control system cooperating with plug and use hardware modules provides reliable movement that is capable of arranging, stacking, quality checking, in mold inserting etc. Real time remote monitoring and telediagnosis assist better equipment management. USB port allows fast data updating, saving and loading.

- User Friendly

Plug and use industrial connectors achieve simple installation and uninstallation. Servo driven axis provides the possibility of multi points for positioning products and sprues. Multi languages displays and spared communication connections with surrounds machines offer more flexibilities to global customers.



Flip Cylinder

■ Application

The ST3 Series robot is designed for rapid and precise removal of products from injection molding machine, and place them at desired locations. Standard and telescopic arm are selectable to cooperate with 2-plate mold or hot runner system. Capable of arranging, stacking, quality checking and in mold placement. Suitable for injection molding machine under 3600T clamp force.

■ Outline Drawings

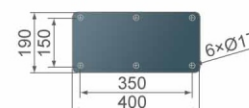
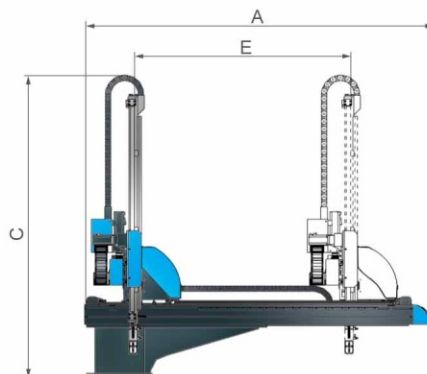
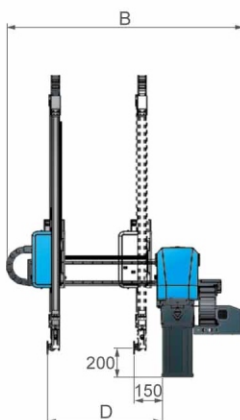

Base Flange

Three Axes Servo

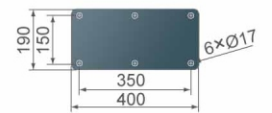
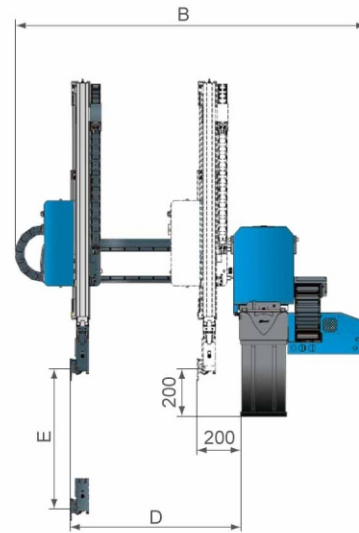
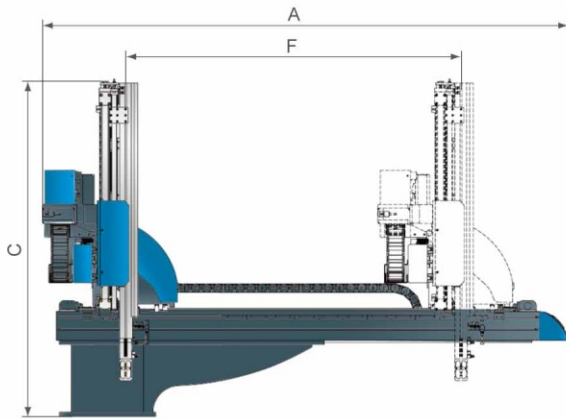

Base Flange

Three Axes Servo Telescopic

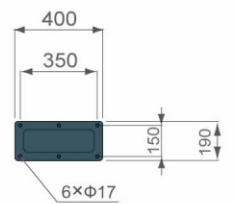
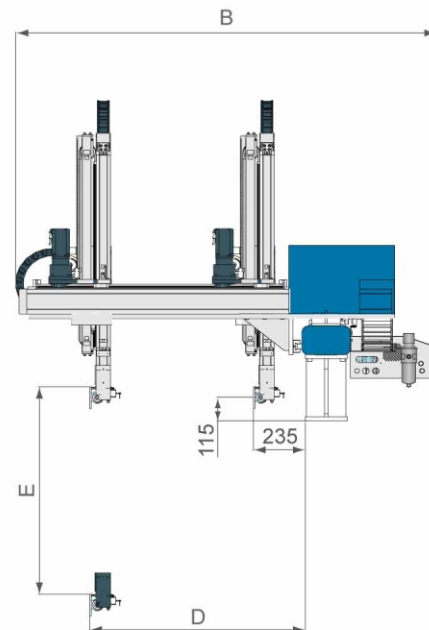
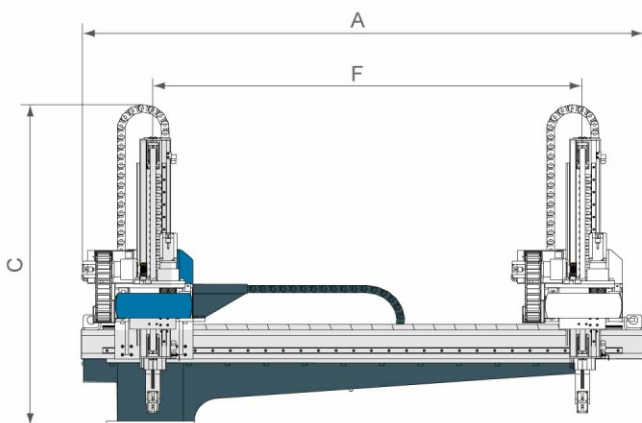

Base Flange

Three Axes Servo Medium Telescopic

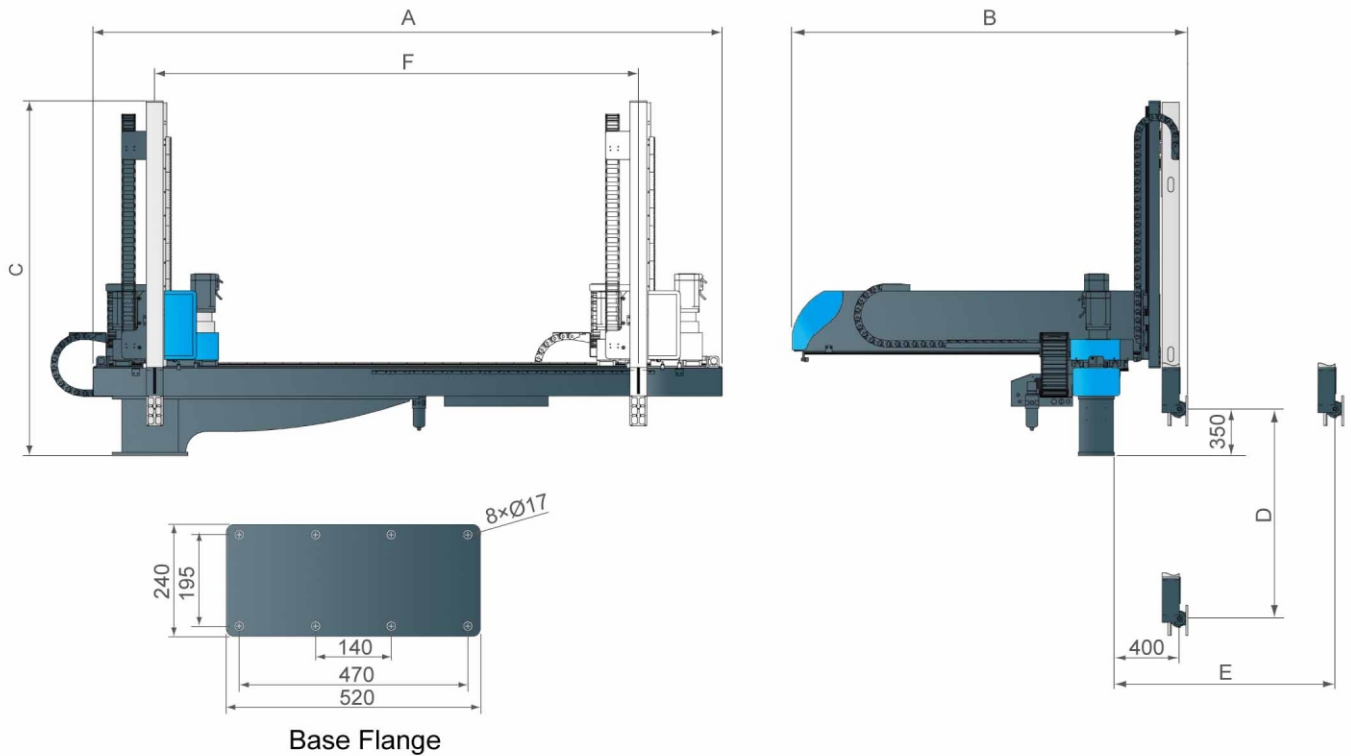

Three Axes Servo Large Telescopic

■ Specifications

Model	ST3-700-1400	ST3-900-1600	ST3-1100-1800	
IMM (ton)	100 ~ 200	200 ~ 300	300 ~ 450	
Traverse Stroke (mm)	1400	1600	1800	
Crosswise Stroke (mm)	500	700	900	
Vertical Stroke (mm)	700	900	1100	
Max Load (with tool) (kg)	3	5	5	
Min Pick-out Time (sec)	2.5	2.7	3	
Min Cycle Time (sec)	7	8	8.5	
Air Pressure (bar)	4 ~ 6	4 ~ 6	4 ~ 6	
Max Air Consumption (NI/cycle) *	4	4	4	
Weight (kg)	260	270	300	
Dimensions (mm)	A	2450	2350	2550
	B	1300	1620	1860
	C	1850	2050	2290
	D	700	900	1100
	E	1400	1600	1800

Note: 1. "M" stands for middle mold detector. (Suitable for three-plate mold.)
 "EM12" stands for EUROMAP 12 communication interface.
 "EM67" stands for EUROMAP 67 communication interface.
 2. Power supply requirement: 1Φ, 200~240V, 50/60Hz.
 3. " * " Max air consumption for suction device 60NI/min.

We reserve the right to change specifications without prior notice.

Model	ST3-700-1400T	ST3-700-1400HT	ST3-900-1600T	ST3-900-1600HT
IMM (ton)	100 ~ 200	100 ~ 200	200 ~ 300	200 ~ 300
Traverse Stroke (mm)	1400	1400	1600	1600
Crosswise Stroke (mm)	480	480	680	680
Vertical Stroke (mm)	700	700	900	900
Max Load (with tool) (kg)	3	3	3	3
Min Pick-out Time (sec)	2.1	0.8	2.3	1
Min Cycle Time (sec)	6	4.3	6.2	4.5
Air Pressure (bar)	4 ~ 6	4 ~ 6	4 ~ 6	4 ~ 6
Max Air Consumption (NI/cycle) *	4	4	4	4
Weight (kg)	240	240	260	260
Dimensions (mm)	A	2450	2300	2300
	B	1300	1540	1540
	C	1360	1550	1550
	D (max)	690	890	890
	E (max)	700	900	900
	F (max)	1400	1400	1600

- Note: 1. "M" stands for middle mold detector. (Suitable for three-plate mold.)
 "EM12" stands for EUROMAP 12 communication interface.
 "EM67" stands for EUROMAP 67 communication interface.
 2. Power supply requirement: 1Φ, 200~240V, 50/60Hz.
 3. "*" Max air consumption for suction device 60NI/min.

We reserve the right to change specifications without prior notice.

Model	ST3-1100-1800T	ST3-1300-2000T	ST3-1500-2200T
IMM (ton)	300 ~ 450T	450T ~ 650T	650T ~ 850T
Traverse Stroke (mm)	1800	2000	2200
Crosswise Stroke (mm)	700	800	900
Vertical Stroke (mm)	1100	1300	1500
Max Load (with tool) (kg)	8	10	12
Min Pick-out Time (sec)	3	3.2	3.5
Min Cycle Time (sec)	8.5	9	9.5
Air Pressure (bar)	4 ~ 6	4 ~ 6	4 ~ 6
Max Air Consumption (NI/cycle) *	5	5	5
Weight (kg)	450	500	550
Dimensions (mm)	A	2600	3000
	B	1900	2100
	C	1600	1700
	D (max)	950	1050
	E (max)	1100	1300
	F (max)	1800	2000

- Note: 1. "M" stands for middle mold detector. (Suitable for three-plate mold.)
 "EM12" stands for EUROMAP 12 communication interface.
 "EM67" stands for EUROMAP 67 communication interface.
 2. Power supply requirement: 1Φ, 200~240V, 50/60Hz.
 3. "*" Max air consumption for suction device 60NI/min.

We reserve the right to change specifications without prior notice.

■ Specifications

Model	ST3-1600-2200LT	ST3-1800-2400LT	ST3-2200-2600LT
IMM (ton)	650 ~ 850T	850 ~ 1600T	1600 ~ 2400T
Traverse Stroke (mm)	2200	2400	3000
Crosswise Stroke (mm)	1180	1340	1500
Vertical Stroke (mm)	1600	1800	2200
Max Load (with tool) (kg)	15	15	20
Min Pick-out Time (sec)	3.2	3.5	3.8
Min Cycle Time (sec)	9	9.5	10
Air Pressure (bar)	4 ~ 6	4 ~ 6	4 ~ 6
Max Air Consumption (NI/cycle) *	6	6	6
Weight (kg)	750	820	890
Dimensions (mm)	A	3430	4230
	B	2350	2650
	C	1960	2260
	D (max)	1600	2200
	E (max)	1500	1900
	F (max)	2200	3000

Model	ST3-2600-2800LT	ST3-3000-3000LT
IMM (ton)	2400 ~ 3000T	3000 ~ 3600T
Traverse Stroke (mm)	3200	3400
Crosswise Stroke (mm)	1660	1820
Vertical Stroke (mm)	2600	3000
Max Load (with tool) (kg)	20	35
Min Pick-out Time (sec)	4	4.3
Min Cycle Time (sec)	10.5	11
Air Pressure (bar)	4 ~ 6	4 ~ 6
Max Air Consumption (NI/cycle) *	6	6
Weight (kg)	960	1030
Dimensions (mm)	A	4430
	B	2820
	C	2460
	D (max)	2600
	E (max)	2050
	F (max)	3200

Note: 1. "M" stands for middle mold detector. (Suitable for three-plate mold.)

"EM12" stands for EUROMAP 12 communication interface.

"EM67" stands for EUROMAP 67 communication interface.

2. Power supply requirement: 1Φ, 200~240V, 50/60Hz.

3. " * " Max air consumption for suction device 60NI/min.



SHINI PLASTICS TECHNOLOGIES, INC.

Headquarters:

Shini Plastics Technologies, Inc.

No.23 Minhe St, Shulin Dist.,
New Taipei City 23852, Taiwan

tel: +886 2 2680 9119

fax: +886 2 2680 9229

email: shini@shini.com

Factories:

- Taipei
- Dongguan
- Ningbo
- Pinghu
- Mumbai