

加熱圈編碼原則 Heater code principle

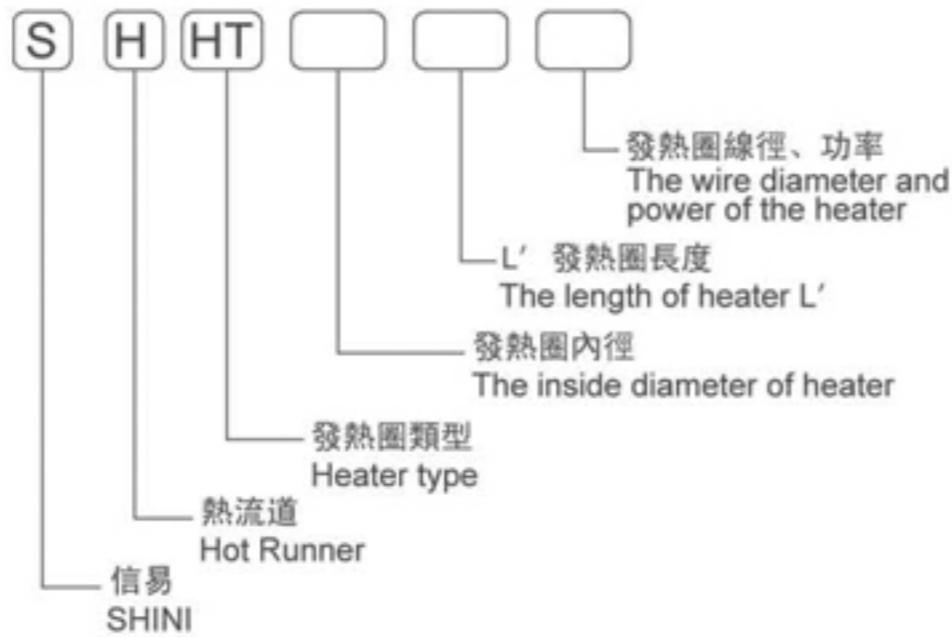

感溫線編碼原則 Thermocouple code principle

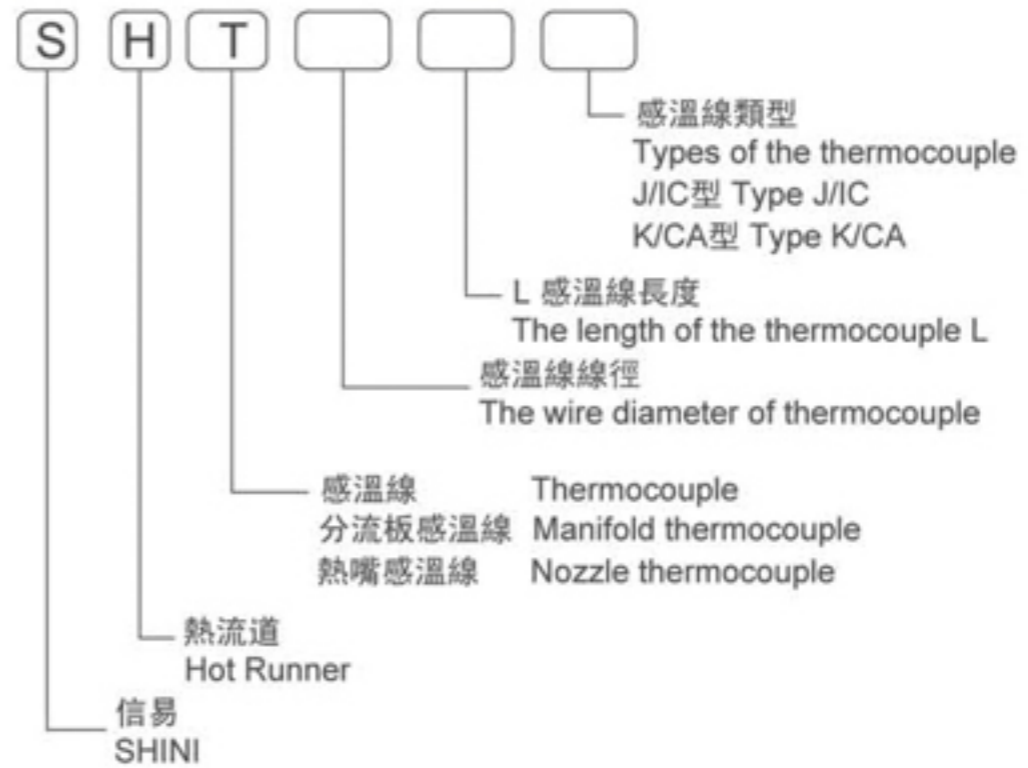

計算加熱圈長度的公式：
 $(\text{ØD} + K) \cdot \pi \cdot \text{圈數} = \text{加熱長度}$
 $(\text{ØD} + K) \cdot \pi \cdot \text{Number of windings} = \text{Heated length}$

測點：底部未接地
 Measuring point: At bottom ungrounded
 溫度範圍：最大值420°
 Temperature range: Max 420°
 導線結構：玻璃棉絕緣附帶保護性金屬套管
 Structure of leads: Glass silk insulated with protective metal sleeve

發熱圈型號 Heater Type	K x C	L'(MM)	ØD(MM)
SHMI	1.3 x 2.3	30-180	Ø10~Ø50
SHC	1.8 x 3.2	30-180	Ø10~Ø50
SHF	2.2 x 4.2	30-180	Ø10~Ø50
SHQ	3.0 x 3.0	30-180	Ø10~Ø50
SHMA	4.6 x 8.6	30-180	Ø18~Ø50

感溫線型號 T/C Type	ØX	L(MM)	R(MM)
SHT	Ø1.0/Ø1.5	100/150/250	2000

All rights reserved.Errors excepted.For a specific application,please consult SHINI.

For design and application information, see the SHINI Hot Runner Guide.

信易熱流道技術規範

SHINI Hot Runner Stack Mold

日期 Date: 年 月 日

基本資料 Basic Information

編號 No.

客戶名稱 Company		電話號碼 Tel		客戶模號 Mold No.	
傳真號碼 Fax		聯繫人 Name		電子郵箱 E-mail	
設計圖號 Designing No.		交圖日期 Sketch Requested Date		交貨日期 Requested Delivery Date	
銷售工程師 Sales Engineer		ID 號 ID No.		送貨單號 Delivery No.	
技術規範性質 (請選擇並在括弧中打√) Nature(Choose and tick √ in bracket)					
報價 Offer()		訂單 Order()		修改 Modify()	
				取消 Cancel()	

產品資料 Product Information

產品名稱 Description		產品重量 Part Weight		產品厚壁 Wall Thickness	
塑膠名稱 Material		出口國家 Exportation Country		產品顏色 Color	

模具資料 Mold Condition

模具尺寸 Mold Size		型腔數量 Cavity No.		球頭半徑 Nose Radius	
模具溫度 Mold Temp		澆口點數 Gate No.		成型要求 Processing Demand	

熱流道系統資料 (請選擇並在括弧中打√) Hot Runner System(Choose and tick √ in bracket)

分流板形狀 Manifold Type I () T () Y () H () X () 非標 Nonstandard ()	澆口位置 Gate Position 產品上 Part () 流道上 Runner ()	三視圖 Three View 主射嘴方向 Main sprue () 分型面方向 Parting surface ()
模具選項 Mold 新模 New () 修改模 Modify () 重複 Repeat ()	模具動力系統 Power System 氣動 Air - powered () 液壓 Hydraulic ()	感溫線 Thermocouple TC () CA ()
模胚尺寸 Mold Base Size		
A板 A Plate	B板 B Plate	C板 C Plate
		D板 D Plate

澆口 Gate	熱嘴型號 Nozzle Type	X	Y	L	澆口直徑 Gate Dia
G1					
G2					
G3					
G4					
G5					
G6					
G7					
G8					

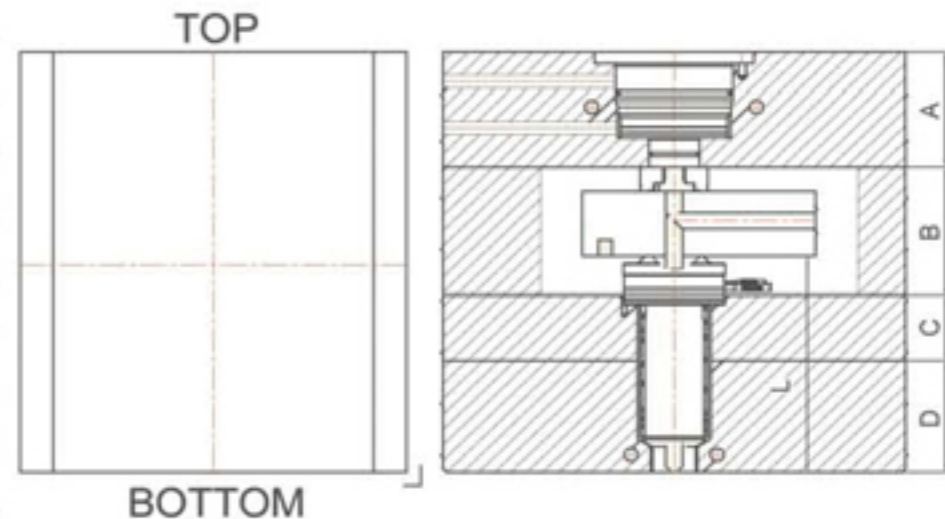

備註(Note):

1. 請客戶先複印此表并填寫好產品資料、模具資料、熱流道系統規格的需求。

Duplicate the form and fill it.

2. 客戶的聯繫電話對我們來說十分重要，請填寫清楚電話號碼。

Your telephone number is very important for us. Please write it clearly.

3. 請將填寫好的表格傳真到 0769 - 83313589 或 E-mail: alex.liu@shinichina.com。

Please fax the completed form to 0769 - 83313589 or set E-mail to: alex.liu@shinichina.com.