

机型版本 Ver. A

					制图	版号	0	标题	SG-L17	图号	比例	第 1 张
					设计	核	准	电气原理图	SG-L17-GB-230V-0-1		标准	共 3 张
					校对	日期					20211115	机器电压
标记	更改前	更改后	更改人	日期	审核	日期	20211115	 信易电热机械股份有限公司 Shini Plastics Technologies, Inc.		机器频率	50Hz	

1 2 3 4 5 6 7 8

1/PE/230V 50/60Hz

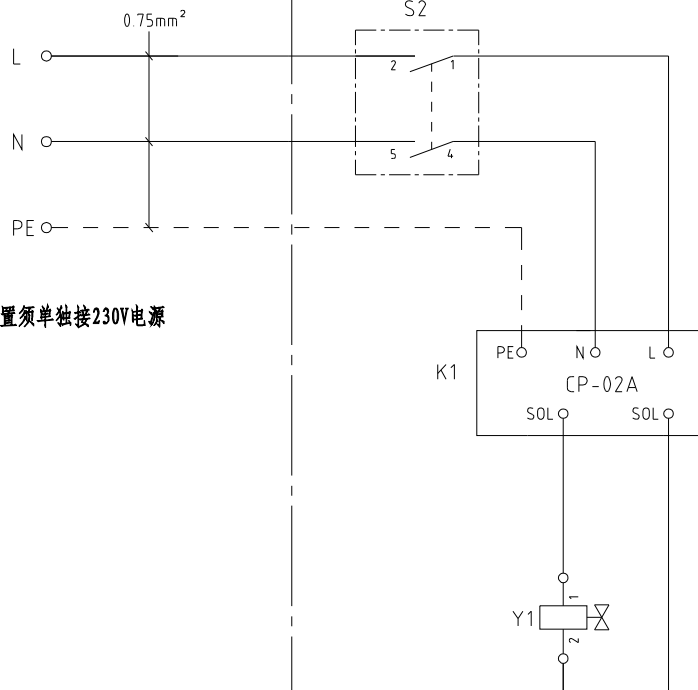

注：VR立即回收装置须单独接230V电源

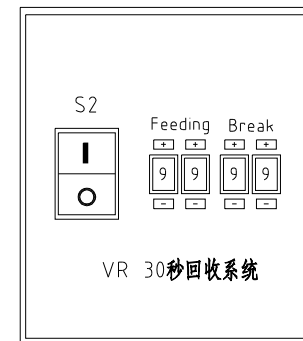

机型版本 Ver.A 选配VR立即回收装置。

					制图		版号	0	标题	SG-L17	图号	比例	第 2 张	
					设计		核 准		电气原理图	SG-L17-GB-230V-0-2		标准	GB	共 3 张
					校对							机器电压	3φ230V	
标记	更改前	更改后	更改人	日期	审核		日期	20211115	 信易電熱機械股份有限公司 Shini Plastics Technologies, Inc.		机器频率	50Hz		

1

2

3

4

5

6

7

8

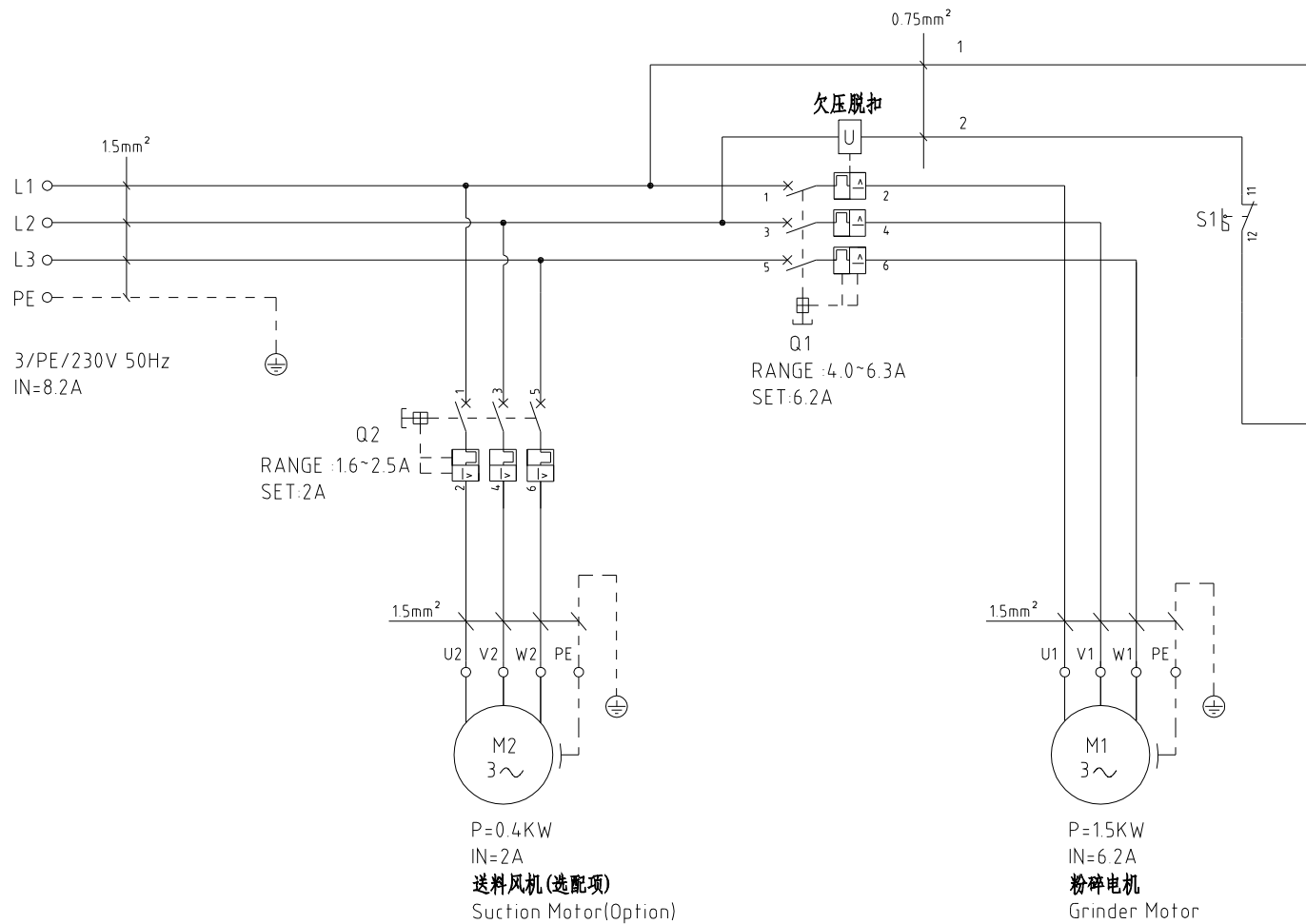

机型版本 Ver. A

					制图	版号	0	标题	SG-L27	图号	比例	第 1 张
					设计	核		电气原理图	SG-L27-GB-230V-0-1	标准	GB	共 3 张
					校对	准		 信易电热机械股份有限公司 Shini Plastics Technologies, Inc.	机器电压	3φ230V		
标记	更改前	更改后	更改人	日期	审核	日期	20211115		机器频率	50Hz		

1 2 3 4 5 6 7 8

1/PE/230V 50/60Hz

注：VR立即回收装置须单独接230V电源

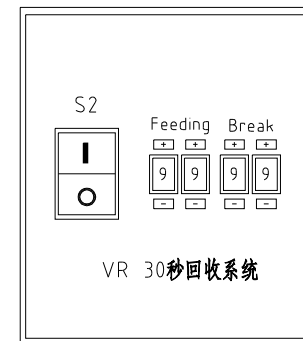
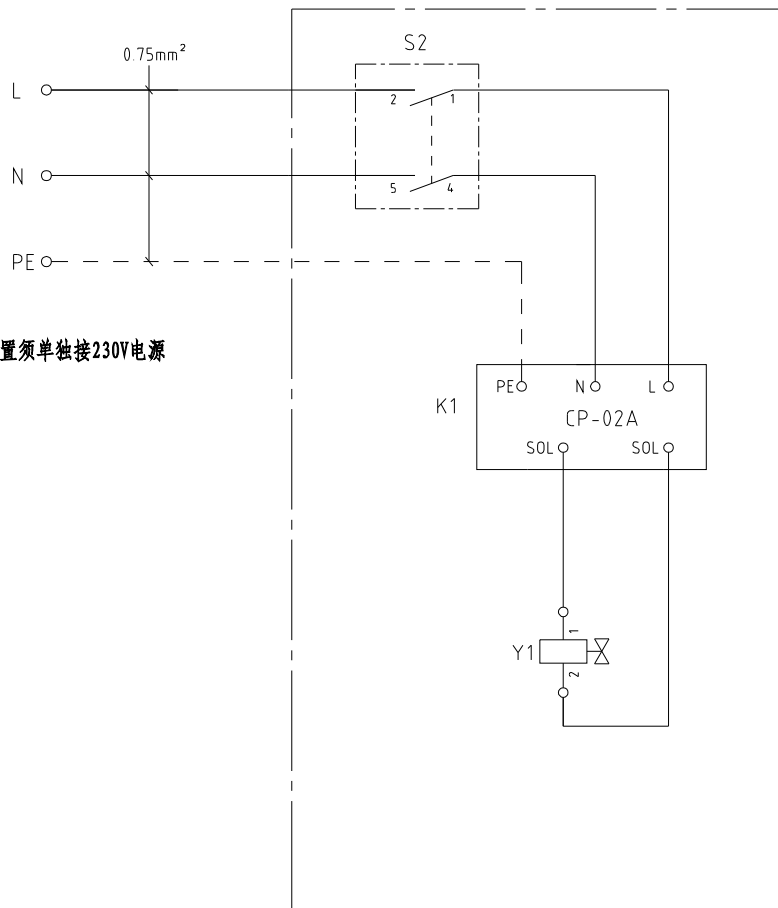

机型版本 Ver A 选配VR立即回收装置。

					制图		版号	0	标题	SG-L27	图号		比例	第 2 张
					设计		核 准		电气原理图	SG-L27-GB-230V-0-2		标准	GB	共 3 张
					校对						机器电压		3φ230V	
标记	更改前	更改后	更改人	日期	审核		日期	20211115	 信易電熱機械股份有限公司 Shini Plastics Technologies, Inc.			机器频率	50Hz	
1	2	3	4	5	6	7	8							

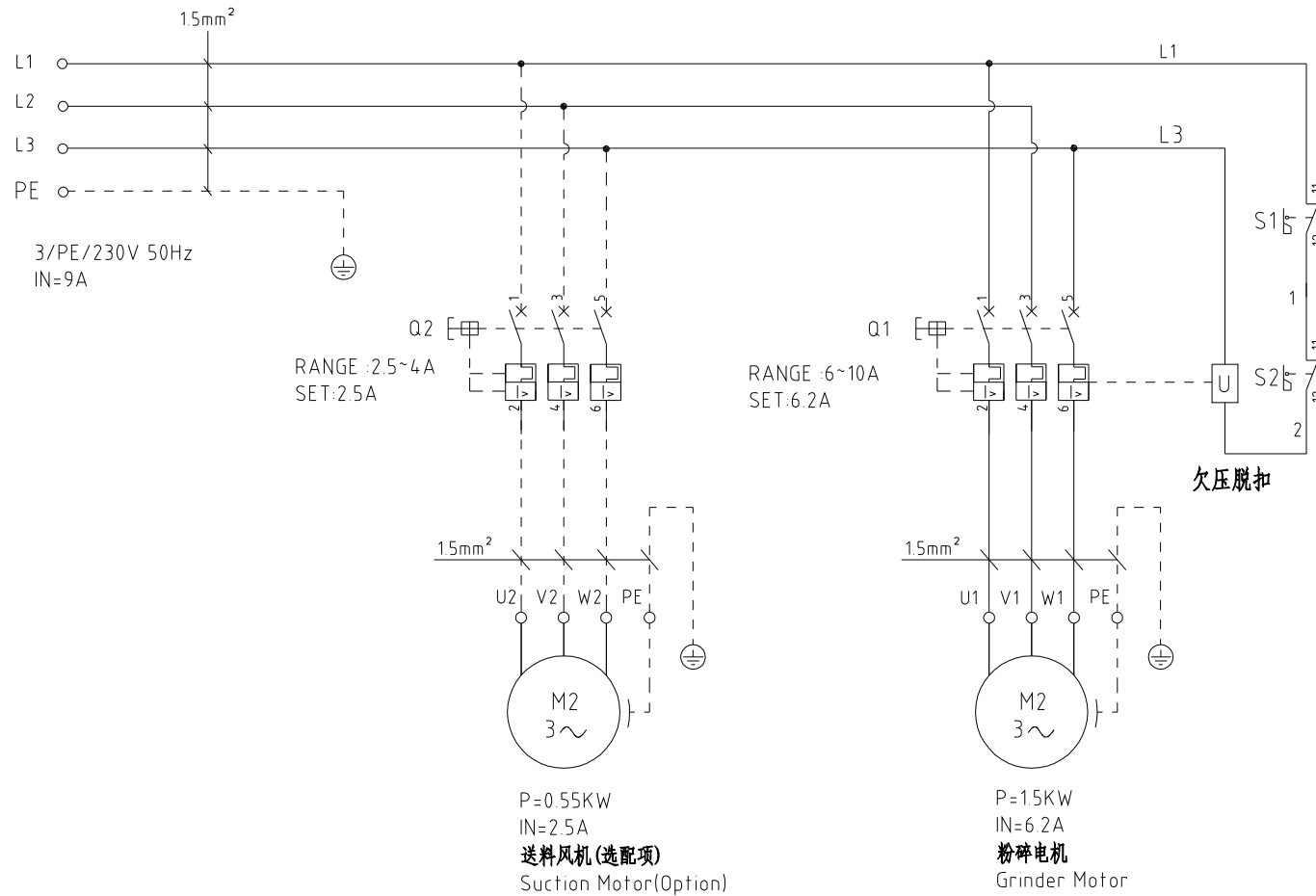

机型版本 Ver.A

制图	版号	0	标题	SG-L32	图号	SG-L32-GB-230V-0-1	比例	第 1 张
设计	核准		电气原理图一				标准 GB	共 3 张
校对	日期	2024.03.09	 信易電熱機械股份有限公司 Shini Plastics Technologies, Inc.		机器电压	3φ230V		
标记	更改前	更改后			更改人	日期	审核	机器频率

1	2	3	4	5	6	7	8
---	---	---	---	---	---	---	---

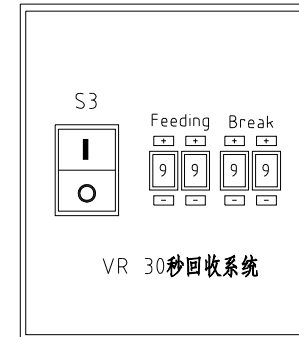
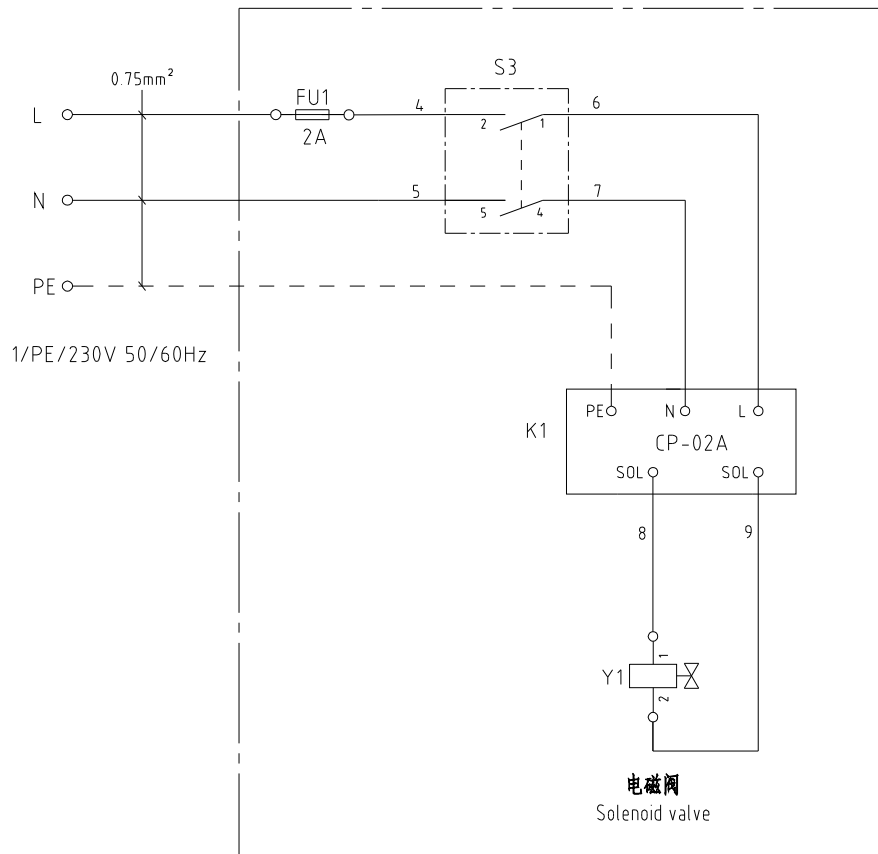

机型版本 Ver A 注：选配VR立即回收装置须单独接230V电源

					制图		版号	0	标题	SG-L32	图号	比例	第 2 张
					设计		核 准		电气原理图二	SG-CE-230V-0-2	标准	CE	共 3 张
					校对							机器电压	3φ230V
标记	更改前	更改后	更改人	日期	审核		日期	20231020	 信易電熱機械股份有限公司 Shini Plastics Technologies, Inc.		机器频率	50Hz	

1 2 3 4 5 6 7 8

1		2		3		4		5		6		7		8																																																																					
序号/NO	符号/Symbol	名称/Name		制造商/Manufacturer		型号/Type		规格/Specification		单位/unit	数量/Number	物料编号/Material number		备注/Remark																																																																					
1	FU1	线型保险/Fuse Box		SHINI		----		2A		PCS	1	YE46000200000		(3)																																																																					
2	Q1	热磁断路器/Circuit-breaker		CHNT		NS2-25		6-10A		PCS	1	YE40022501100		(1)																																																																					
3		欠压脱扣器/Undervoltage release		CHNT		NS2-UV220		220V		PCS	1	YE40222000900		(1)																																																																					
4		防水安装盒/Waterproof-box		CHNT		NS2-MC01		----		PCS	1	YR40012000000		(1)																																																																					
5	Q2	热磁断路器/Circuit-breaker		CHNT		NS2-25		2.5-4A		PCS	1	YE10250400100		(1)(2)																																																																					
6		防水安装盒/Waterproof-box		CHNT		NS2-MC01		----		PCS	1	YR40012000000		(1)(2)																																																																					
7	S1	安全开关/Safety switch		SCHMERSRC		TEND/TZ-9212		AZ-15		PCS	1	YE16921200000		(1)																																																																					
8	S2	安全开关/Safety switch		SCHMERSRC		AZ16-02ZVRK-M16-1476-1		AZ-16		PCS	1	YE16147600000		(1)																																																																					
9	S3	切替开关/Safety switch		----		R210-C5LBW4P		10A 250V		PCS	1	YE10210400000		(3)																																																																					
10	K1	VR拨码器/Time Dialer		YUYUN		CP-02A		AC220V		PCS	1	YE80222000600		(3)																																																																					
11		电线0.75*1C*200M红色								M	3	YE50750100000		(1)																																																																					
12		端子1.25-4Y(1000PCS/包)								PAC	0.016	YE60100440200		(1)																																																																					
13		管形端子E1008								PCS	8	YE60100800200		(1)																																																																					
14		电缆锁头PG9								PCS	1	YE67000940000		(1)																																																																					
15		电缆线1.5*4C*1.1M								BA	1	BE51150403250		(1)																																																																					
16		电缆线1.5*4C*4M								BA	1	BE51150400250		(1)																																																																					
17		电线0.75*3C*4M(中性线(零线)使用蓝色)								M	4	YE50050300100		(1)																																																																					
18		电缆线1.5*4C*1.1M								BA	1	BE51150403250		(1)(2)																																																																					
19		电线0.75*3C*4M(中性线(零线)使用蓝色)								M	4	YE50050300100		(1)																																																																					
20	Y	电磁阀/Solenoid valve		AIRTAC		----		4V210-08/AC220V		PCS	1	----		(2)																																																																					
21	M1	粉碎电机/Granulating Motor		SHIYUAN		1.5kW		230V 50Hz		PCS	1	----		(1)																																																																					
22	M2	吸料风机/Solution blower		REXCHIP		0.55KW		230V 50Hz		PCS	1	-----		(1)(2)																																																																					
<p>机型版本 Ver.A 注：(1)表示非电控箱安装；(2)表示(PC)或(PR)送料风机选配件；(3)选配VR立即回收装置。</p> <table border="1"> <tr> <td colspan="2">制图</td> <td colspan="2">版号</td> <td colspan="2">0</td> <td colspan="2">标题</td> <td colspan="2">SG-M29</td> <td colspan="2">图号</td> <td colspan="2">比例</td> <td colspan="2">第 3 张</td> </tr> <tr> <td colspan="2">设计</td> <td colspan="2">核准</td> <td colspan="2"></td> <td colspan="2">电气元件明细表</td> <td colspan="2">SG-M29-CE-230V-0-3</td> <td colspan="2">标准</td> <td colspan="2">CE</td> <td colspan="2">共 3 张</td> </tr> <tr> <td colspan="2">校对</td> <td colspan="2">审核</td> <td colspan="2"></td> <td colspan="2" rowspan="2">  信易電熱機械股份有限公司 Shini Plastics Technologies, Inc. </td> <td colspan="2">机器电压</td> <td colspan="2">3φ230V</td> </tr> <tr> <td colspan="2">标记</td> <td colspan="2">更改前</td> <td colspan="2">更改后</td> <td colspan="2">更改人</td> <td colspan="2">机器频率</td> <td colspan="2">50Hz</td> </tr> <tr> <td colspan="2">日期</td> <td colspan="2">日期</td> <td colspan="2">20231020</td> <td colspan="2"></td> <td colspan="2"></td> <td colspan="2"></td> </tr> </table>																制图		版号		0		标题		SG-M29		图号		比例		第 3 张		设计		核准				电气元件明细表		SG-M29-CE-230V-0-3		标准		CE		共 3 张		校对		审核				 信易電熱機械股份有限公司 Shini Plastics Technologies, Inc.		机器电压		3φ230V		标记		更改前		更改后		更改人		机器频率		50Hz		日期		日期		20231020							
制图		版号		0		标题		SG-M29		图号		比例		第 3 张																																																																					
设计		核准				电气元件明细表		SG-M29-CE-230V-0-3		标准		CE		共 3 张																																																																					
校对		审核				 信易電熱機械股份有限公司 Shini Plastics Technologies, Inc.		机器电压		3φ230V																																																																									
标记		更改前		更改后				更改人		机器频率		50Hz																																																																							
日期		日期		20231020																																																																															
1		2		3		4		5		6		7		8																																																																					