

SGB series

Gravimetric Blender

Date: Dec. 2017

Version: Ver. C (English)



Contents

1. General Description	9
1.1 Coding Principle	10
1.2 Feature	10
1.3 Technical Specifications	12
1.3.1 Technical Specifications.....	12
1.3.2 Specifications	13
1.4 Safety Regulations	16
1.4.1 Safety Rules for Touch Screen	16
1.4.2 Safety Signs and Labels	16
1.4.3 Transportation and Storage of the Machine	17
1.4.4 Sources of Danger	18
1.4.5 Safety Device	20
1.4.6 Specified Use	21
1.4.7 Attentions for Operators and Maintenance Personnel.....	21
1.5 Exemption Clause	22
2. Structure Characteristics and Working Principle	23
2.1 Main Function	23
2.1.1 Working Principle	23
2.2 Optional Accessories	25
2.2.1 Floor Stand and Material Storage Tank Combination	25
2.2.2 Induction Motor Driven Feeding Device	25
2.2.3 Material Level Switch	26
3. Installation and Debugging	27
3.1 Installation of SGB.....	27
3.1.1 Install SGB machine on a floor stand	27
3.1.2 SGB Install SGB on a Molding Machine.....	28
3.1.3 Installation of SGB Weighing pan.....	28
3.2 Power Connection	29
3.3 Compressed Air Supply	30
3.4 Installation of Feeding Function (Optional with vacuum generator) ...	30
4. Application and Operation	33

4.1	Starting Up.....	33
4.1.1	Turn on the Main Power Switch	33
4.2	Interface Operation Flow	33
4.3	About Keyboard Interface	35
4.3.1	Input and Edit Alphabetic and Numerical Value	35
4.3.2	Alternative Options.....	36
4.4	Log in/out.....	37
4.4.1	Administrator Log in	37
4.4.2	Administrator Log out.....	38
4.5	Interfaces Details.....	38
4.5.1	System Initial Interface.....	38
4.5.2	Feeding/Weighing Selecting Interface.....	40
4.5.3	Weighing Monitoring Interface (Taking four ingredients as example, and models of other ingredients are as the same). Selecting weighing system under feeding/weighing selecting interface and the system will display the weighing monitoring interface which can also be displayed by touching return key under other interfaces.....	40
4.5.4	Weighing Data View Interface	42
4.5.5	Recipe Setting Interface.....	43
4.5.6	Recipe Elements.....	44
4.5.7	Menu Interface	46
4.5.8	Parameter Setting Interface	47
4.5.9	Calibration Interface	49
4.5.10	User Management Interface.....	50
4.5.11	Manual Mode Interface	51
4.5.12	Unit Parameter Setting Interface	53
4.5.13	Alarm Message Interface	54
4.5.14	Control of Feeding.....	55
4.6	Level sensor	56
4.6.1	Adjustment of Material Level Switch	56
4.6.2	Functions of Each Level Switch	57
4.7	Components Instructions.....	59
4.7.1	Components category definition and distribution principle	59
4.8	Calculation Method of Master-batch and additives	62

4.8.1 Appendix 4: Chromatic Aberration Compensation of Reclaimed Material	63
4.8.2 Appendix 7: Blending Motor Locked-rotor Inspection Switch	63
4.9 Control Mode	64
4.9.1 Weighing Metering Mode	64
4.9.2 Volumetric (Time) Metering Mode	64
4.9.3 Mixing Metering Mode	65
5. Trouble-shooting	66
6. Maintenance and Repair	69
6.1 Maintenance	69
6.2 Filter & Pressure Regulating Valve	70
6.2.1 Filter & Pressure Regulating Valve Drawing	70
6.2.2 Filter & Pressure Regulating Valve Operation steps	70
6.3 Storage Hopper Cleaning	70
6.4 Scale Pan Cleaning	70
6.5 Clean Mixing Chamber	71
6.6 Magnetic Base Cleaning	71
6.7 Clean Material Shut-off Plate	72
6.8 Maintenance Schedule	73
6.8.1 About the Machine	73
6.8.2 Check after Installation	73
6.8.3 Daily Checking	73
6.8.4 Weekly Checking	73
6.8.5 Monthly Checking	73

Table Index

Table 1-1: Specifications 1	13
Table 1-2: Specifications 2	14
Table 1-3: SVG Specifications	15
Table 3-2: Feeding Installation Specification	31
Table 4-1: List of Keyboard Screen	35
Table 4-2: List of Symbol Screen	36

Table 4-3: List of Administrator Login Screen.....	37
Table 4-9: List of Formula Setting Screen	43
Table 4-13: List of User Management Screen	50
Table 4-14: List of Manual Mode Screen.....	51
Table 4-16: List of Alarm Checking Screen	54

Picture Index

Picture 1-1: Technical Specifications	12
Picture 1-2: Magnetic Base	13
Picture 1-3: Floor Stand Assembly.....	13
Picture 1-4: Sources of Danger	18
Picture 1-5: Safety Device.....	20
Picture 2-1: Working Principle	23
Picture 2-2: Vertical Cone-dosing.....	24
Picture 2-3: Floor Stand and Material Storage Tank Combination	25
Picture 2-4: Induction Motor Driven Feeding Device	25
Picture 2-5: Material Level Switch	26
Picture 3-1: SGB-600-4 (Install SGB Machine on a Floor Stand).....	27
Picture 3-2: Machine Mount	28
Picture 3-3: Floor Mount.....	28
Fig. 3-4: SGB-40-4 Weighing pan Installation Diagram	29
Fig. 3-5: Weighing pan Installation Diagram of SGB-200 and above Models	29
Fig. 3-6: Feeding Installation Diagram (Optional with vacuum generator)	31
Picture 4-2: Initiating Image	33
Picture 4-3: Interface Operation Flow.....	34
Picture 4-4: Keyboard Interface.....	35
Picture 4-5: On-screen Keyboard.....	36
Picture 4-8: Administrator Log in	37
Picture 4-9: System Initial Interface.....	38
Picture 4-10: Feeding/Weighing Selecting Interface	40
Picture 4-11: Weighing Monitoring Interface	40
Picture 4-12: Weighing Data Display Interface 1	42

Picture 4-13: Weighing Data Display Interface 2.....	42
Picture 4-14: Recipe Setting Interface.....	43
Picture 4-15: Recipe Elements.....	44
Picture 4-16: Menu Selection	46
Picture 4-17: Parameter Setting Interface	47
Picture 4-18: IP Setting Interface	48
Picture 4-19: Weightlessness Parameter Interface	48
Picture 4-20: Calibration Interface.....	49
Picture 4-21: User Management Interface	50
Picture 4-22: Manual Mode Interface	51
Picture 4-23: Unit Parameter Setting Interface.....	53
Picture 4-24: Alarm Message Interface	54
Picture 4-25: Selection Screen of Feeding System and Weight System.....	55
Picture 4-26: Feeding Monitoring Screen.....	55
Picture 4-27: Feeding Parameters Screen	56
Picture 4-28: Feeding Monitoring Screen.....	56
Fig. 4-26: Level Sensor Adjustment.....	57
Picture 4-30: Level Switch on Hopper	58
Picture 4-31: Level Switch on Mixing Tank	58
Picture 4-32: Level Switch on storage Tank.....	59
Picture 4-33: Blending Motor Locked-rotor Inspection Switch.....	63
Picture 6-1: Filter & Pressure Regulating Valve Drawing	70
Picture 6-2: Drawing of Scale Pan Cleaning	71
Picture 6-3: Clean Mixing Chamber	71
Picture 6-4: Drawing of Magnetic Base Cleaning	71

1. General Description



Read this manual carefully before operation to prevent damage of the machine or personal injuries.

SGB series gravimetric blender can be used in the fields of injection molding machines, blow molding machines and extrusion lines for proportionally precise mixing of several types of material. This series machines adopt Becca levy PLC controller and latest ingredients calculation methods. The machine is controlled by an advanced microprocessor with a digital display that is simple to calibrate. The self-compensation and calibration function ensure accurate material dosing percentages. A high precision electronic weighing scale is used to ensure precise weighing of every batch and ensure accuracy to $\pm 0.1\% \sim 0.3\%$. There are 8 models available to be selected based on various materials and throughputs. (This series are not suitable for powder and sheet pieces weighing)



Model: SGB-200-4(Machine Mount)

1.1 Coding Principle

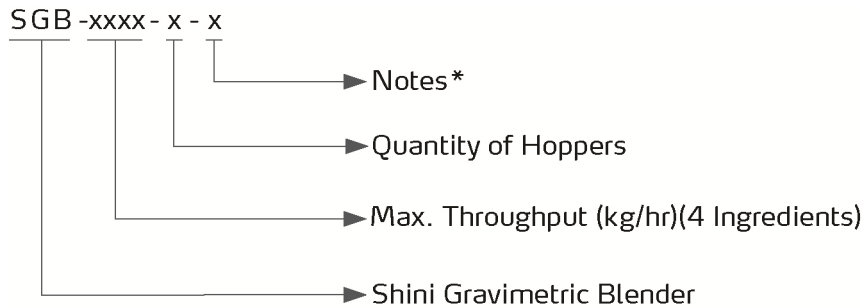

Notes: *
CE=CE Conformity

1.2 Feature

1) Standard configuration

- The micro-scale metering accuracy is $\pm 0.1\%$ when all materials are blended through gravity.
- Auto calibration function which is performed every time after material weighting ensures best proportioning accuracy.
- Up to 100 recipes can be stored for future use.
- Have alarm history record function.
- SGB-600 and models below are directly mounted on machines.
- For SGB-1200 and models above, floor stand is the standard supply (equipped with floor stand, material storage tank and pneumatic discharge valve).
- Adopt Ethernet communication function to realize online centrally monitor function.
- With function of material auto-suction control.

2) Accessory option

- Hopper low material level sensor is optional for advance warning when lacking materials.
- Floor stand, pneumatic discharge valve, storage bin and suction box should be equipped for floor mounting. (Applicable for SGB-600 and models below).
- Vacuum generator SVG and central hopper receiver SHR-U-ST are optional.

- Microscale metering valve is optional for SGB-40/200/600 to meter materials with proportion of 0.2%-0.5%.
- Special material metering valve is optional for metering sheets or irregular materials whose diameters are within 12×12×12mm.
- Optional data-collection function can read actual additive proportion, output, all kinds of materials' total amount and output rate of every lot of virgin or recycling material, master-batch and additives.
- Function of recycled material auto-compensation is optional (recycling hopper should option with low level switch). Aberration compensation can be automatically calculated according to the discharging amount of recycled materials.

All service work should be carried out by a person with technical training or corresponding professional experience. The manual contains instructions for both handling and servicing. Chapter 6, which contains service instructions intended for service engineers. Other chapters contain instructions for the daily operator.

Any modifications of the machine must be approved by SHINI in order to avoid personal injury and damage to machine. We shall not be liable for any damage caused by unauthorized change of the machine.

Our company provides excellent after-sales service. Should you have any problem during using the machine, please contact the company or the local vendor.

Headquarter and Taipei factory:

Tel: (886) 2 2680 9119

Shini Plastics Technologies (Dongguan), Inc:

Tel: (86) 769 8111 6600

Shini Plastics Technologies India Pvt. Ltd.:

Tel: (91) 250 3021 166

1.3 Technical Specifications

1.3.1 Technical Specifications

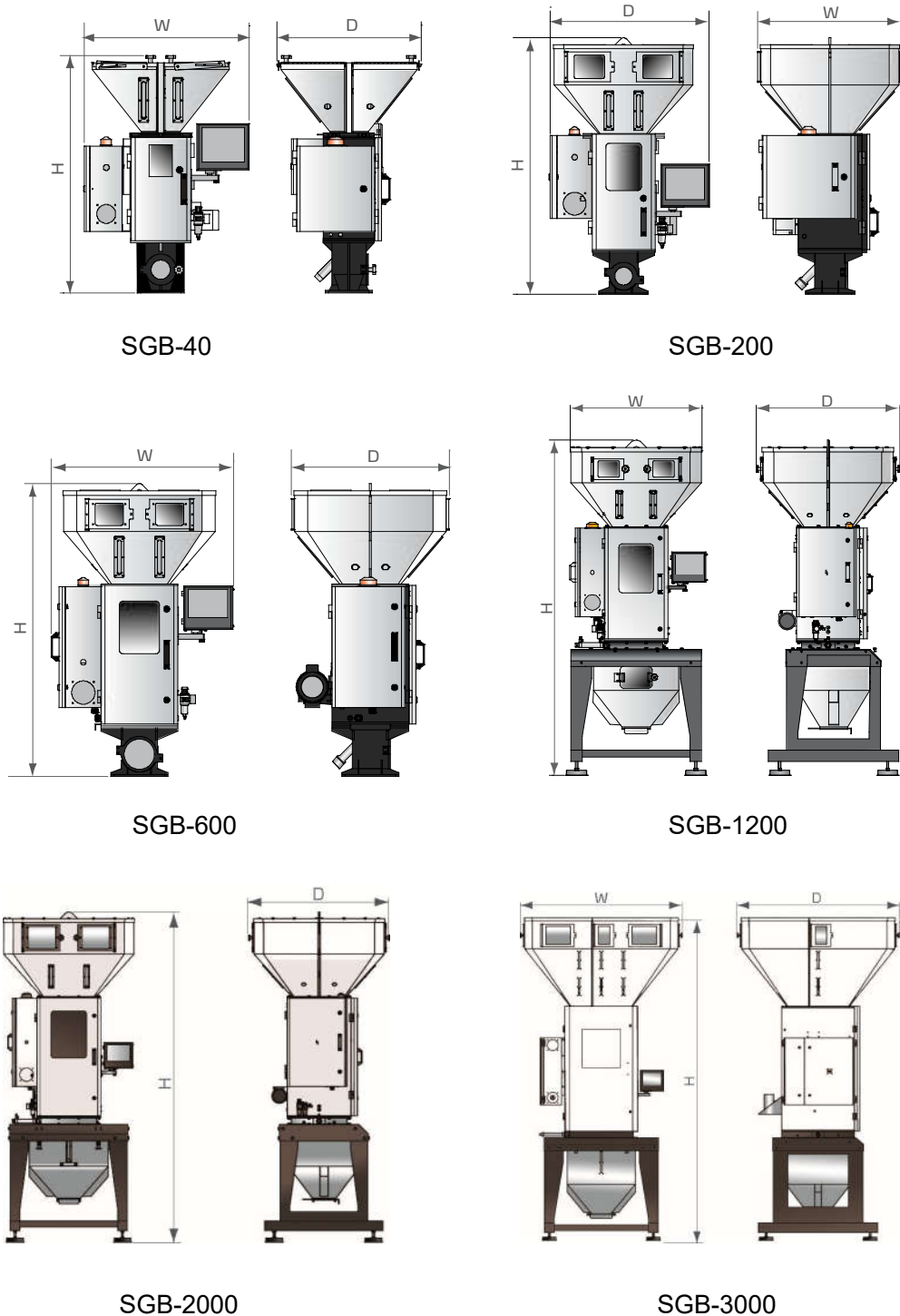

Picture 1-1: Technical Specifications

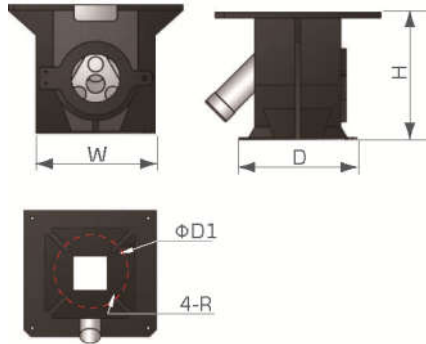

Picture 1-2: Magnetic Base

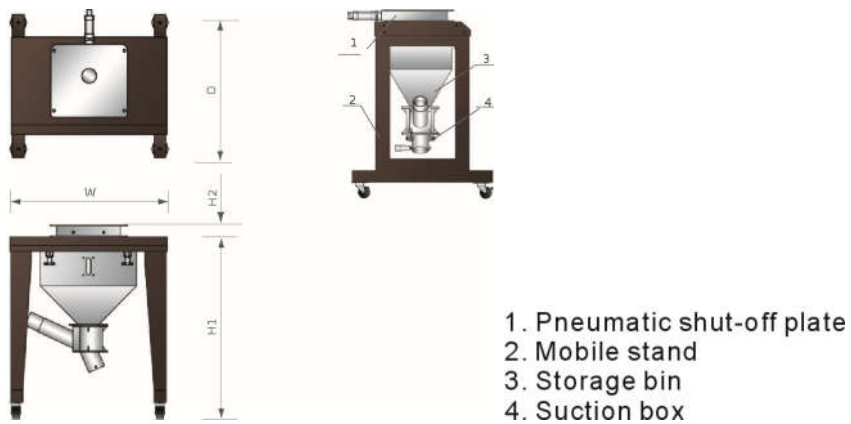

Picture 1-3: Floor Stand Assembly

1.3.2 Specifications

Table 1-1: Specifications 1

Model	SGB-40	SGB-200	SGB-600	SGB-1200	SGB-2000	SGB-3000
Ver.	C	C	C	C	C	B
H(mm)	1110	1300	1445	2398	2800	3375
W(mm)	770	815	905	940	1110	1695
D(mm)	675	735	785	1023	1180	1695
Magnetic Base (mm) (W×D×H×ΦD1×R)	220×220×243.5 ×160×6.5	250×250×213 ×200×6	280×280×250 ×220×6	-	-	-
Mobile Stand (mm) (H1×H2×W×D)	713×50 ×654×600	880×50 ×724×800	885×60 ×814×800	900×60×930 ×930	1000×65 ×1060×1000	1075×70 ×1240×1240
Net Weight (kg) (Machine Mount)	115	135	160	-	350	650
Net Weight(kg) (Floor Mount)	135	170	220	400	500	850

Table 1-2: Specifications 2

Model	Ingredients	Main metering valve	Secondary metering valve	Max. Batch	Mixing Motor Power	Max. Output	
				(kg)	(kW)	(kg/hr)	
SGB-40-	4	4	3	1	1.0	0.25	40
SGB-200-	4	4	3	1	3.0	0.25	200
SGB-600-	6	6	4	2	8	0.55	400
	4	4	3	1			600
SGB-1200-	6	6	4	2	12	0.55	900
	4	4	3	1			1200
SGB-2000-	8	8	5	3	18	0.55	1200
	6	6	4	2			1600
	4	4	3	1			2000
SGB-3000-	8	8	5	3	40	0.75	2000
	6	6	4	2			2500
	4	4	3	1			3000

Note: 1) The above data is based on continuous running of even particles whose bulk densities are 0.8kg/L and diameters are 3~4mm.

The values vary along material features. Please further discuss if the material is not sure.

- 2) The main metering valve is suitable for proportion not lower than 5% and raw material of even particles or recycled materials of even particles whose diameters are within $6 \times 6 \times 6$ mm.
- 3) The secondary metering valve is suitable for proportion of 0.5%~5% and master batch of even particles or additives whose diameters are within $4 \times 4 \times 4$ mm.
- 4) Microscale metering valve is optional for proportion of 0.2%~0.5% and master batch of even particles or additives whose diameters are within $4 \times 4 \times 4$ mm.
- 5) Special material metering valve is suitable for sheets and irregular materials whose diameters are within $12 \times 12 \times 12$ mm.
- 6) Mixing and ratio deviation refers to the difference between the setting percent and actual percent of each group. The microscale metering accuracy can reach to $\pm 0.1\%$.
- 7) Come with a set of secondary metering valves for use when replacing recipe.
- 8) Power specifications of the blending motor: 1 Φ , 400VAC, 50Hz.

Table 1-3: SVG Specifications

Model		Vacuum generator	Power (kW)	Central hopper receiver	Hopper capacity(L)	Transporting pipe(inch)	Suction pipe(inch)
SGB-40	-4	SVG-1HP	0.75	4×SHR-3U-ST	3	1.5	2
SGB-200	-4	SVG-2HP	1.5	4×SHR-6U-ST	6	1.5	2
SGB-600	-6	SVG-3.5HP	2.4	6×SHR-12U-ST	12	1.5	2
	-4	SVG-3.5HP	2.4	4×SHR-12U-ST	12	1.5	2
SGB-1200	-6	SVG-5HP	3.75	6×SHR-12U-ST	12	1.5	2
	-4	SVG-7.5HP	5.5	4×SHR-24U-ST	24	2	2.5
SGB-2000	-8	SVG-7.5HP	5.5	4×SHR-24U-ST	24	2	2.5
	-6	SVG-10HP	7.5	6×SHR-36U-ST	36	2	2.5
	-4	SVG-10HP-D	7.5	4×SHR-36U-ST	36	2	2.5
SGB-3000	-8	SVG-10HP-D	7.5	8×SHR-36U-ST	36	2	2.5
	-6	SVG-20HP-D	13	6×SHR-48U-ST	48	2.5	3
	-4	SVG-20HP-D	13	4×SHR-48U-ST	48	2.5	3

Notes: 1) "T" means the material suction pipe is T joint.

2) Power: 3Φ, 400VAC, 50Hz.

1.4 Safety Regulations

Please abide by following safety regulations when to operate to prevent personal injuries and damage of the machine.

1.4.1 Safety Rules for Touch Screen

- 1) Do not use keen-edged object to replace hands to operate the touch screen, and prevent violent collision by outside force.
- 2) In a dry environment, static electricity may accumulate on the touch screen. Use a metal wire to discharge it before operating.
- 3) Use alcohol or eleoptene to wipe off the pollutants on the screen. Other solvent may cause the color of the screen to fade out.
- 4) Do not tear down any parts of the touch screen or take away any PCBs attached to it.

In the event of loss or damage to a key of a trapped key interlocking device, the complete key lock unit shall be replaced.

1.4.2 Safety Signs and Labels



Electrical installation should be done by qualified electricians. Turn off the main switch and control switch before servicing and maintenance.



Warning! High voltage!

The sign is attached on the cover of control box!



Warning! Be careful!

Be more careful at the place where this sign appears!



Feeding strip materials can give rise to an entanglement hazard.



Attention!

No need for regular inspection because all the electrical parts in the control unit are fixed tightly!

1.4.3 Transportation and Storage of the Machine

Transportation

- 1) SGB series gravimetric blender is packed in crates or plywood cases with wooden pallet at the bottom, suitable for quick positioning by fork lift.
- 2) Optional floor stand with castors can be used for ease of movement.
- 3) Do not rotate the machine and avoid collision with other objects during transportation to prevent improper functioning.
- 4) The structure of the machine is well-balanced, although it should also be handled with care when lifting the machine for fear of falling down.
- 5) The machine and its attached parts can be kept at a temperature from -25°C to $+55^{\circ}\text{C}$ for long distance transportation and for a short distance, it can be transported with temperature under $+70^{\circ}\text{C}$.

Storage

- 1) SGB series gravimetric blender should be stored indoors with temperature kept from 5°C to 40°C and humidity below 80%.
- 2) Disconnect all power supply and turn off main switch and control switch.
- 3) Keep the whole machine, especially the electrical components away from water to avoid potential troubles caused by the water.
- 4) Plastic film should be used to protect the machine from dust and rains.

Working environment

The machine should be operated:

- 1) Indoors in a dry environment with max. temperature $+45^{\circ}\text{C}$ and humidity no more than 80%.

Do not use the machine:

- 1) If it is with a damaged cord.
- 2) On a wet floor or when it is exposed to rain to avoid electrical shock.
- 3) If it has been dropped or damaged until it is checked or fixed by a qualified serviceman.
- 4) This equipment works normally in the environment with altitude within 3000m.
- 5) At least a clearance of 1m surrounding the equipment is required during operation. Keep this equipment away from flammable sources at least two meters.

6) Avoid vibration, magnetic disturbance at the operation area.

Rejected parts disposal

When the equipment has run out its life time and can't be used any more, unplug the power supply and dispose of it properly according to local code.

Fire hazard



In case of fire, CO₂ dry powder fire extinguisher should be applied.

1.4.4 Sources of Danger

The equipment is designed and made combining the most advanced technology with the well-acknowledged safety-first engineering rules. Nevertheless, the operation on this equipment might also endanger the life and limbs of the operator or any other third person, or cause damage to equipment itself or other properties.

There are four sources of danger as indicated in the following chart:

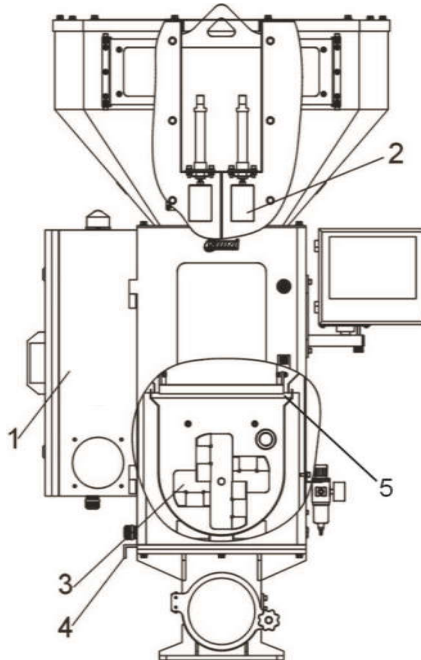

Picture 1-4: Sources of Danger

Please refer to the following table for specific statement:

Table 1-4: Sources of Danger

NO.	Source of Danger	Consequences	Precaution Measure
1	ECU	Fatal damage caused by electric shock High-pressure electricity will generate life-threatening current within human body and cause electric shock	1) Only trained and qualified professional technicians can operate ECU 2) Please shut down the switch of power supply before conduct any electric repair work
2	Valve body of the main and sub metering valve	Damages such as roller compaction, collision and shearing, etc owing to the adjacency to parts	Do not touch the valve body or any active parts such as screw during normal and manual operation
3	Blending blade in the mixing barrel	Damages such as roller compaction, shearing and cutting, etc caused by mobile parts	1) Never touch the mixing chamber when the mixer is rotating 2) No extending any object to reach the active radius of the mixer 3) No stopping the use of safety interlock switch 4) Please put on gloves while touching or cleaning the static mixer
4	Plug-in strip at the bottom of the mixing vat	Damages such as roller compaction, collision and shearing, etc owing to the adjacency to parts	Never touching the plug-in strip during normal and manual operation
5	Shut-off plate of weighing pan	Damages such as roller compaction, collision and shearing, etc owing to the adjacency to parts	Never touch the shut-off plate of the weighing pan during normal and manual operation.

1.4.5 Safety Device

Safety device can guarantee your health and life. Don't operate this equipment if it is not equipped with valid safety device.

Please refer to the following chart for the location of safety device.

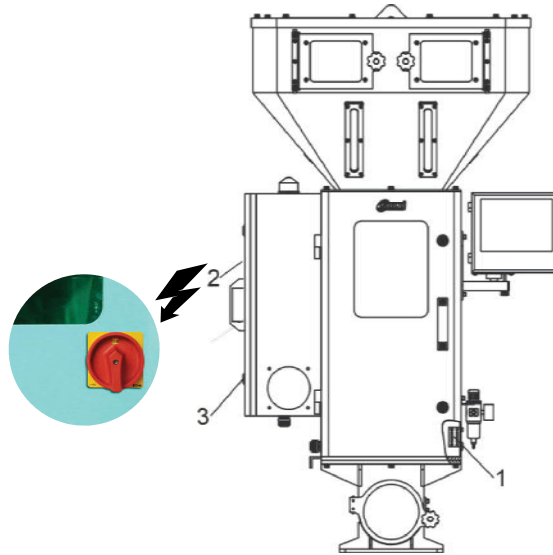

Picture 1-5: Safety Device

Please refer to the following table for the specific statement

Table 1-5: Safety Device

N0.	Safety Device	Safety Measure
1	Mechanical safety switch	Stop the running of the mixing motor when front safety door is open
2	Main power switch (emergency stop switch)	Stop all acts of the machine
3	Door lock	Lock control cabinet to avoid any unauthorized person from getting close to the dangerous electric components

1.4.6 Specified Use

Standard SGB Gravimetric Blender can be only used for measuring and mixing plastic particles and additives, etc with natural flow.

It can never be used for measuring the following raw materials:

- 1) Food of any category (the equipment does not satisfy the standard for food sanitation device).
- 2) Raw materials with high abrasiveness such as stone, sand, etc (it will accelerate the abrasion of equipment components).
- 3) Inflammable and explosive chemical raw materials such as sulfur and metal powder, etc (collision of measuring device might cause combustion or explosion).
- 4) Raw materials with bad performance in natural flow or those with performance of viscosity (those raw materials have bad flow performance and are inclined to bridge, which will influence the measuring function).
- 5) Fluid and powder (measuring valve does not accord with air-tightness design standard).

1.4.7 Attentions for Operators and Maintenance Personnel

Personnel who are about to operate and maintain this equipment must read carefully related contents in this operation instruction book especially those related to safety before they start relevant operations.

The following statement on safety is very important for avoiding human injury and property loss:

- 1) Abide by all information related to safety and damage of the equipment.
- 2) No unauthorized personnel are allowed to get close to this equipment.
- 3) Please make sure that no person is within the radius of danger each time when the machine is started.
- 4) Please make sure that there is no tool, other equipment or object in the work station. Do not place tools or other objects on the equipment. Vibration might cause falling off of the above-mentioned objects, which will cause human injury and/or property loss.
- 5) Please keep both the equipment and working place clean. Besides, please make sure that no particle can be found on the ground, which might make

working personnel fall down and get injured.

- 6) Please put on work glove while cleaning or maintaining mixer. Work glove will protect both hands and fingers from being cut off.
- 7) Please abide by safety work regulations made by local government while operating this machine.

1.5 Exemption Clause

The following statements clarify the responsibilities and regulations born by any buyer or user who purchases products and accessories from Shini (including employees and agents).

Shini is exempted from liability for any costs, fees, claims and losses caused by reasons below:

1. Any careless or man-made installations, operation and maintenances upon machines without referring to the Manual prior to machine using.
2. Any incidents beyond human reasonable controls, which include man-made vicious or deliberate damages or abnormal power, and machine faults caused by irresistible natural disasters including fire, flood, storm and earthquake.
3. Any operational actions that are not authorized by Shini upon machine, including adding or replacing accessories, dismantling, delivering or repairing.
4. Employing consumables or oil media that are not appointed by Shini.

2. Structure Characteristics and Working Principle

2.1 Main Function

The SGB series Gravimetric Blender can be installed on extrusion lines, injection molding machines and blow molding machines etc. for precise mixing of several types of material. The machine is controlled by an advanced microprocessor with a digital display that is simple to calibrate. The self-compensation and calibration function ensure accurate material percentages. There are total 12 models with dosing capacity ranging from 40 to 2,000 kg/hr.

2.1.1 Working Principle

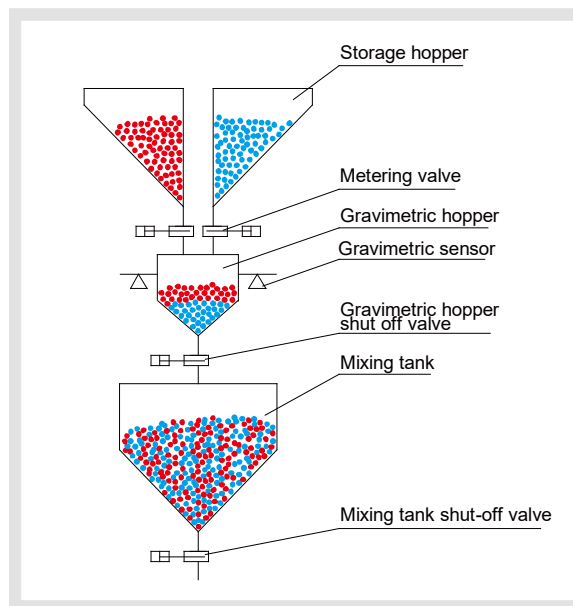

Picture 2-1: Working Principle

When machine starts working, metering valve of storage hopper 1 opens to let material fall into gravimetric hopper according to the preset weight and time; when time is up, the valve shut down and gravimetric sensor inside gravimetric hopper responses that weight reaches the default value, then the next storage hopper metering valve opens. The material metering repeats like this until all the hoppers finish feeding. Then the gravimetric hopper shut-off valve opens to let materials fall into mixing tank to be blended. Once material in gravimetric hopper falls into mixing tank, gravimetric hopper shut-off valve shuts. Mixers keep working

for a period of set time and afterwards the pneumatic slide gate will be open manually or automatically to let material falls into storage tank or injection molding machine. Until here, a complete operation circle has been finished.

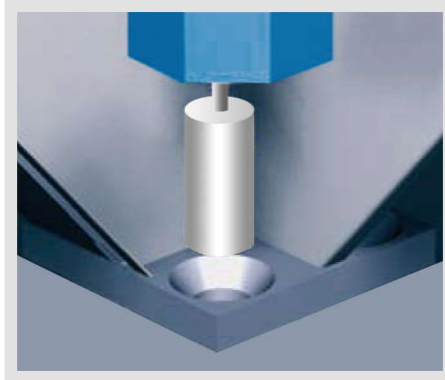

Picture 2-2: Vertical Cone-dosing

Shini newly developed vertical cone-dosing metering valve ensures the accurate metering of granules. At present, the cone-dosing metering valve is applicable on the models with 200kg/hr throughput and above.

2.2 Optional Accessories

2.2.1 Floor Stand and Material Storage Tank Combination

For SGB-600 and models below, movable floor stand and material storage tank are optional (including European type suction box).

For SGB-1200 and models above, moveable floor stand and material storage tank are standard (excluding European type suction box).

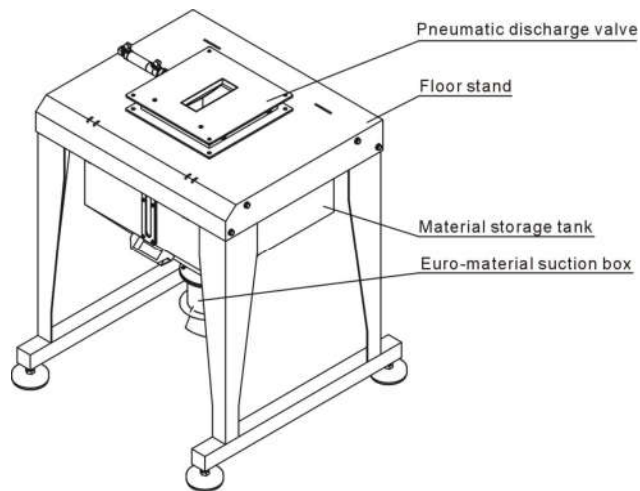

Picture 2-3: Floor Stand and Material Storage Tank Combination

2.2.2 Induction Motor Driven Feeding Device



Picture 2-4: Induction Motor Driven Feeding Device

2.2.3 Material Level Switch

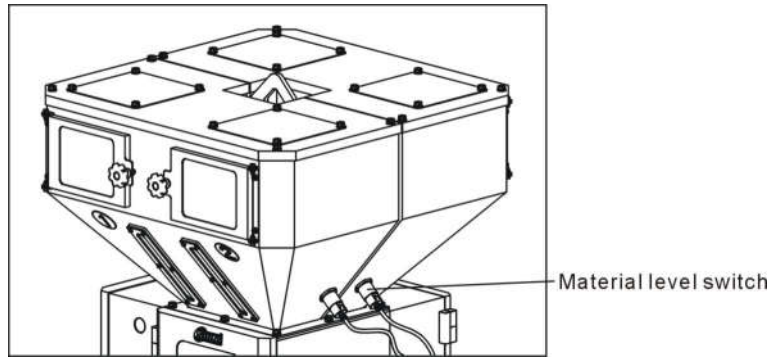

Picture 2-5: Material Level Switch

3. Installation and Debugging

Read this chapter before installation. Install the machine according to following steps!

Power supply of the machine should be connected by professional electricians!

3.1 Installation of SGB

3.1.1 Install SGB machine on a floor stand



Picture 3-1: SGB-600-4 (Install SGB Machine on a Floor Stand)

SGB can be installed on an optional mobile floor stand to be used with material storage bin and suction box (optional).

3.1.2 SGB Install SGB on a Molding Machine

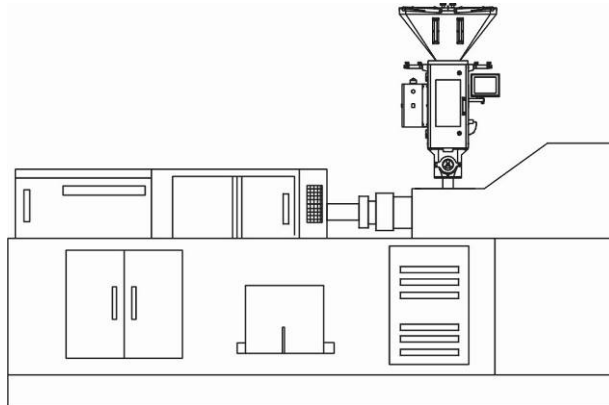

Picture 3-2: Machine Mount

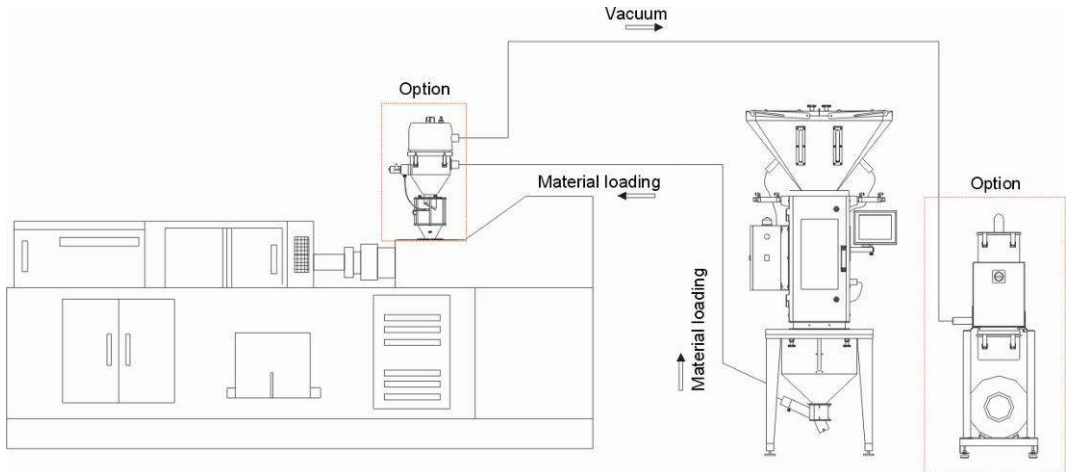

Picture 3-3: Floor Mount

3.1.3 Installation of SGB Weighing pan

SGB weighing pan is separated with the machine before delivery, which should be correctly mounted before the use of machine.

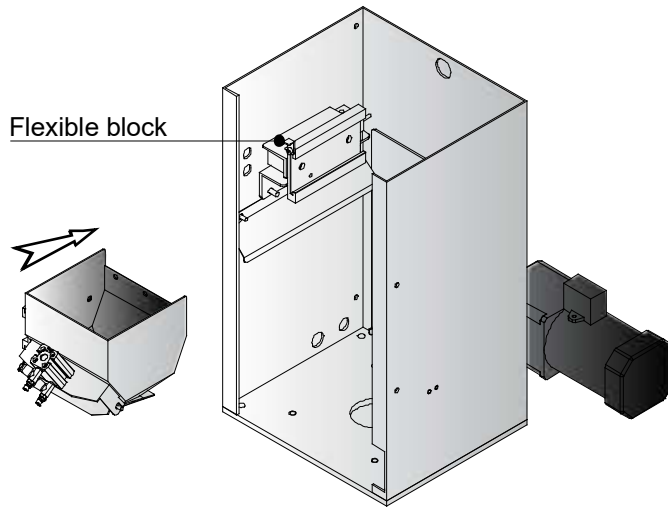

Fig. 3-4: SGB-40-4 Weighing pan Installation Diagram

When the flexible block is adjusted to suitable angle, slide the weighing pan into the guiding rail groove, and then twist the block with fixation to prevent the weighing pan from slipping out.

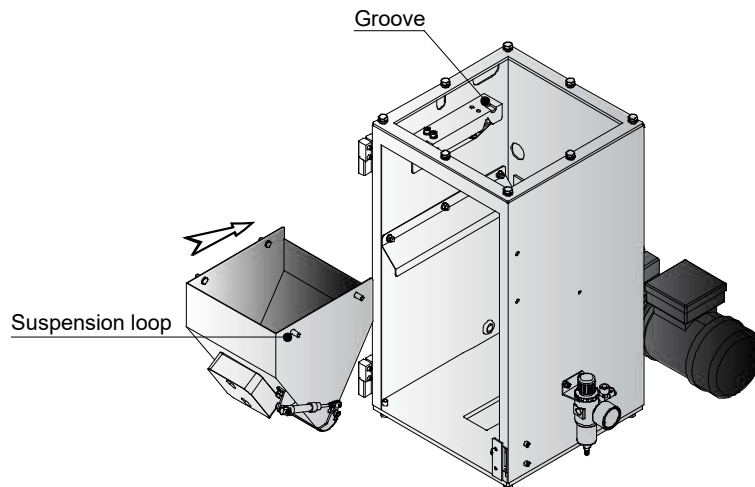

Fig. 3-5: Weighing pan Installation Diagram of SGB-200 and above Models

Mount the weighing pan along the arrow direction, and aim the four hanging ears at the groove of the weighing pan's supporting block. Then, adjust to keep the balance after the placement.

3.2 Power Connection

- 1) Make sure the voltage and frequency of the power source comply with those indicated on the manufacturer nameplate that attached to the machine.
- 2) Power cable and earth connection should conform to your local regulations.
- 3) Use independent electrical wires and power switch. Diameter of electrical wire should not be less than those used in the control box.
- 4) The power cable connection terminals should be tightened securely.
- 5) The machine requires 3-phase 4-wire power source, connect the power lead (L1, L2, L3) to the live wires, and the earth (PE) to the ground.
- 6) Power supply requirements:
 Main power voltage: +/- 5%
 Main power frequency: +/- 2%
- 7) ***Please refer to electrical drawing of each model to get the detailed power supply specifications***

3.3 Compressed Air Supply

Table 3-1: Compressed Air Specification

Items	Value	Remark
Quality Grade	335	Solid particle content $\leq 5\text{mg/m}^3$, dew-point temperature $\leq -20^\circ\text{C}$, oil content $\leq 25\text{mg/m}^3$, oil content $\leq 25\text{mg/m}^3$. (Chinese standard: GB/T 13277-1991)
Air pressure (bar)	3~5bar	
Air quantity (L/hr)	~10L/hr	
Pipe dimension	PM20	Quick coupler(Chinese standard)

3.4 Installation of Feeding Function (Optional with vacuum generator)

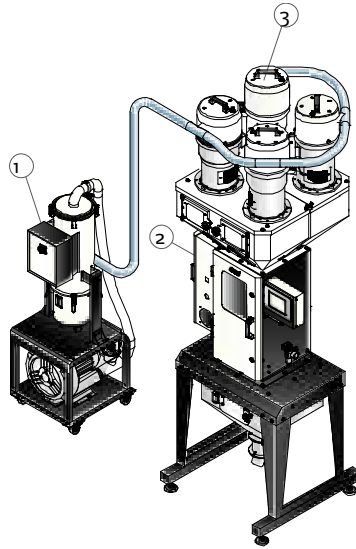

Fig. 3-6: Feeding Installation Diagram (Optional with vacuum generator)

Table 3-2: Feeding Installation Specification

NO.	Name	Description
1	SVG	Central Vacuum Generator
2	SGB	Gravimetric Blender
3	SHR	European vacuum hopper receiver

Installation Space

When installing the machine, make sure the adequate installation space (at least 1m reserved around the machine). It is not good for machine operation, inspection and maintenance when installing in narrow space.

Installation Method

- 1) Place the vacuum generator in suitable place and connect the power line.
- 2) Install the central vacuum hopper on the SGB, and connect the signal to the control box of SGB.
- 3) Connect the air suction inlet of vacuum hopper with the wired hose.
- 4) Connect the high-pressure air pipe (pressure of 4-8kgf/cm²) to the hopper loader.

5) Parameters of specific collocation please refer to (Table 1-3: SVG Specification Table)

4. Application and Operation

SGB series gravimetric blender is manipulated through touch screen, which can rotate for convenient operation. Please obey the following rules while using it:

- 1) Don't use sharp objects (instead of hands) to touch the screen. And, screen should be prevented from fierce collision.
- 2) Under the environment of dry air, lots of static electricity will be generated on the screen. Thus, before touch the screen, grounding metal should be used to discharge the static electricity.
- 3) Use economical and applicable alcohol or light oil to scrub the screen. Any other solvent will fade the screen.
- 4) Never make bold to demount the touch screen and take away any PCB in it, or elements might be damaged.

4.1 Starting Up

4.1.1 Turn on the Main Power Switch

Switch the main power switch to 1, the starting position initiating image shall be displayed as below:

Select operation language by touching the button at lower right corner and enter the feeding/weighing interface.



Picture 4-1: Initiating Image

4.2 Interface Operation Flow

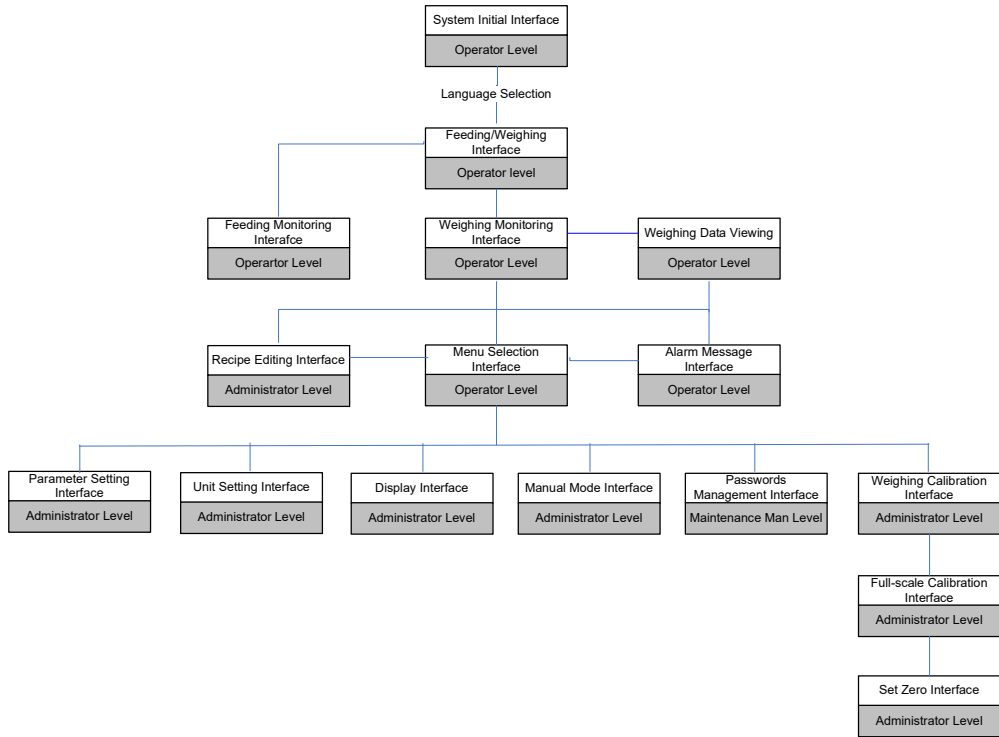

Picture 4-2: Interface Operation Flow

4.3 About Keyboard Interface

Touch the parameter input or setting area and a numerical or alphabetic numerical on-screen keyboard will come out to complete the man-machine conversation (parameter setting). Keyboard will automatically disappear after the input completes.

4.3.1 Input and Edit Alphabetic and Numerical Value



Picture 4-3: Keyboard Interface

Steps:

User may input both numbers and hexadecimal values one character by another by using the numerical on-screen keyboard.

- 1) Touch the related parameter setting domains on the touch screen
Numerical on-screen keyboard will be opened and display the current value.
- 2) Set value
The operability of keys depends on the types of the values to be input. User can input values in accordance with the following method:

Table 4-1: List of Keyboard Screen

No.	Name	Description
1	cancel	cancel the input
2	left selection	select to the left
3	switch	switch the upper case and lower case
4	single character switch	switch the upper case and lower case of the signal character
5	cancel	cancel all the numbers or characters
6	confirm	confirm

7	switch the keyboard symbol	switch to the keyboard symbol
8	switch the numeric key	switch to the keyboard number
9	right selection	select to the right
10	cancel	cancel all the numbers or characters at the left of the cursor

Note: If there is maximum/minimum limit, only values within the limits can be input. The system will refuse any value out of the limits and reset the original one.

4.3.2 Alternative Options

1) On-screen Keyboard

Touch the select input are on the touch screen and the keyboard will come out, and it will disappear when the input finished.

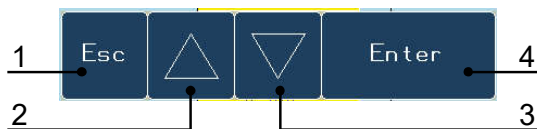

Picture 4-4: On-screen Keyboard

Table 4-2: List of Symbol Screen

No.	Name	Description
1	exit key	cancel input
2	increase key	increase
3	decrease key	decrease
4	confirm key	confirm

2) Steps:

Parameter select can be set via the select on-screen keyboard.

Steps are as below:

- 1) Touch the relevant area in the screen. The keyboard will come out.
- 2) Press <increase key> and <decrease key> to choose the input item.
- 3) Use <confirm key> to confirm the input values or use <exit key> to cancel it, after the operations the on-screen keyboard will be closed.

1) Feeding process is forced to stop.

4.4 Log in/out

4.4.1 Administrator Log in

User must use the log dialogue box to confirm operation limit when it is necessary to execute operations as administrator or repairman. Input user name and password in log dialogue box.

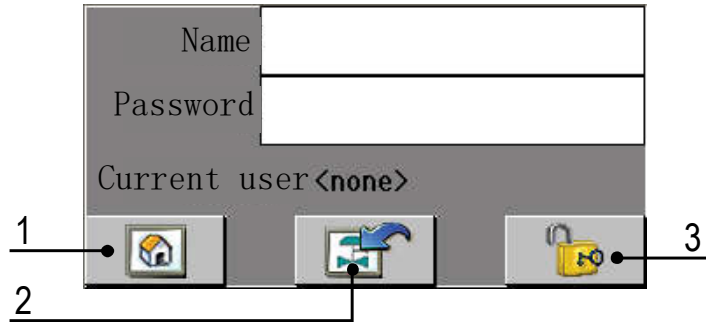

Picture 4-5: Administrator Log in

Table 4-3: List of Administrator Login Screen

No.	Name	Description
1	homepage key	return to the homepage
2	login key	administrator login
3	unlock key	cancel the lock

1. The steps are as follows:

Input username and password

Touch the corresponding input field. The alphanumeric screen keyboard will be displayed

Touch <unlock key> button

Touch < Login key > login system

Notice: user name is case insensitive while password is case sensitive.

2. Result

After logging in successfully, you can execute functions under the password protection within manipulation limit range on HMI equipment. A piece of wrong message will appear when the wrong password is input. At that time, no client logs in the project.

3. Level of users and passwords

No.	Level	Log-in User	Log-in Password	Operation Range
0	Operation level	None	None	Weighing supervision, alarm check and refueling
1	Administrator level	shini	3588	In comparison with limits of authority of operator, it has authorities such as formula editing, parameter setting, starting of manual mode and volume measuring mode and weight correction.
2	Maintenance man level	shiniwx	3333	In comparison with limits of authority of administrator's, it has authorities such as user management and ex-works parameter setting.

Note: the above-mentioned user names and passwords can be modified under user management interface.

4.4.2 Administrator Log out

If there is no action in 5 minutes after logging in as an administrator, the system will automatically log out and log in as an operator. The administrator user must login again when operating the process with password protection.

4.5 Interfaces Details

4.5.1 System Initial Interface

After switch on the power, the touch screen will display the initial interface which can also be displayed by touching the first left key at the bottom the screen.



Picture 4-6: System Initial Interface

No.	Items	Description
1	Software version number	Display the version number of the current PLC and HMI.

2	Language selection keys: English/Traditional Chinese	Select the operation language: English or Chinese, and then system will enter feeding/weighing interface.
---	---	---

4.5.2 Feeding/Weighing Selecting Interface

After selecting language under the initial interface, the system will display feeding/weighing selecting interface.

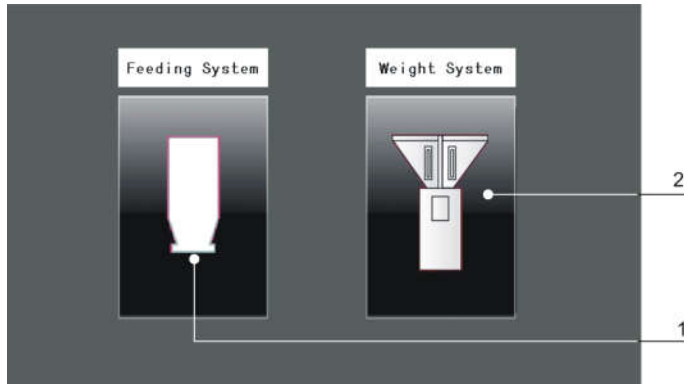

Picture 4-7: Feeding/Weighing Selecting Interface

No.	Items	Description
1	Feed system key	Enter the feeding monitoring interface.
2	Weighing system key	Enter the weighing monitoring interface.

4.5.3 Weighing Monitoring Interface (Taking four ingredients as example, and models of other ingredients are as the same). Selecting weighing system under feeding/weighing selecting interface and the system will display the weighing monitoring interface which can also be displayed by touching return key under other interfaces.

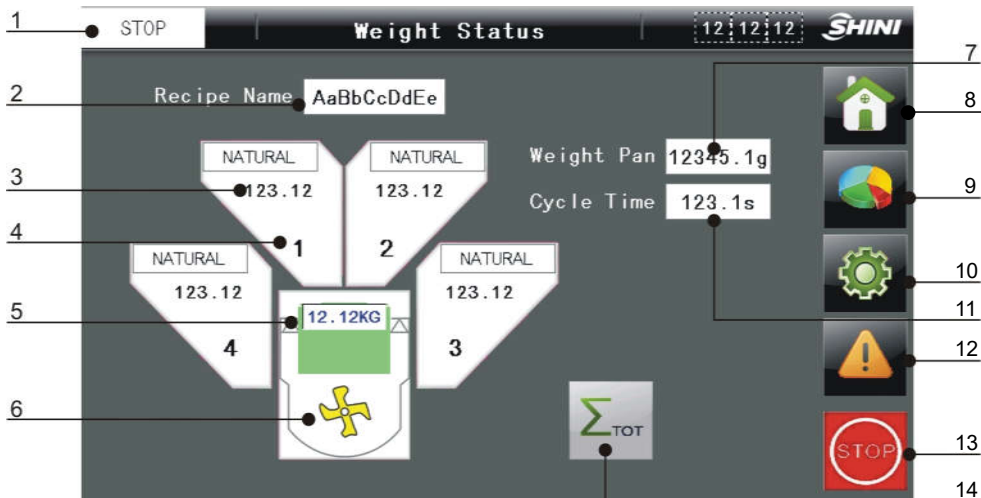

Picture 4-8: Weighing Monitoring Interface

No.	Items	Description
1	Working condition	Display the current work condition Stop: denotes the machine is in stopping condition. Full hopper: denotes the blending hopper is full. Running: denotes machine is in automatically metering and discharging condition. Alarm: denotes system failure.
2	Recipe document number	Display the number of current recipe document.
3	Setting percentage of each hopper	Display percentage of each hopper. Usually, the percentage of hopper 1 is automatically computed. Enter the recipe setting menu to modify the percent of each hopper.
4	Display the metering status of each hopper	ON indicates the current hopper is in metering status.
5	Batch capacity	Display the current batch capacity. It needs to enter parameter setting interface to modify the parameters.
6	Operation status of mixer	When mixer is running, this symbol will be blinking.
7	Weight display	It displays current weight and the actual batch weight shall deduct the tare weight displayed before the batch processing.
8	Homepage	Select to enter the main screen
9	Recipe setting button	Select to enter formula setting interface.
10	Menu selection button	Press this button to enter menu selection. Note: only when machine is under stop condition, the menu selection can be entered.
11	Time for each batch	Display the whole time for one batch.
12	Alarm checking button	Select to enter alarm check interface.
13	Start/stop button	When the machine is in stop condition, press this button to start the system. When the machine is under running condition, press this button to stop the system.
14	Next page button	Press this button to enter weighing data display interface.

4.5.4 Weighing Data View Interface

Touch<screen switch>in weighing monitoring, the system will display the weighing date view interface.

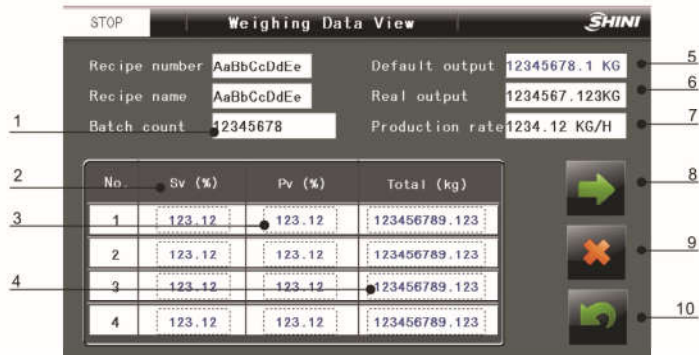

Picture 4-9: Weighing Data Display Interface 1

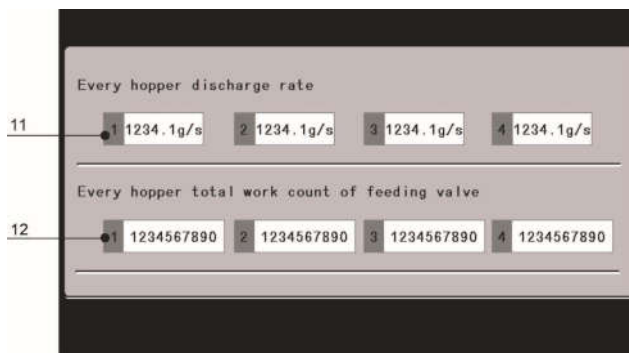

Picture 4-10: Weighing Data Display Interface 2

NO.	Items	Description
1	Accomplished yield	It displays batch number from the last accumulation clearance to current time.
2	Preset percentage of each hopper	Preset percentage of each hopper
3	Actual percentage of each hopper	It displays actual percentage of each barrel last time.
4	Accumulated amount of each hopper	Accumulated amount of each hopper from last time accumulation clearance to current time.
5	Estimated yield	The preset yield can be set. If the yield of machine reaches this set value, alarm and stop the machine.
6	Actual yield	Accumulated yield within certain period (30 minutes for

		ex-works setting) divided by time (unit: hour) is actual yield per hour.
7	Production rate	It displays the maximum yield within an hour. It is acquired through the calculation of both time and amount for processing with each batch, which changes according to different process time.
8	Next page button	The interface will go to the next page by touching this button.
9	Accumulation Clearance Key	Reset accumulated projects in each hopper and batch number counter for accomplished production.
10	Return Key	Return to the weighing monitoring interface.
11	Measurement rate of each hopper	Display the discharging rate of each discharging valve.
12	Accumulated numbers of actions of each discharging valve	Display the accumulated number of actions of each discharging valve.

4.5.5 Recipe Setting Interface

Enter recipe setting interface by pressing Recipe Setting

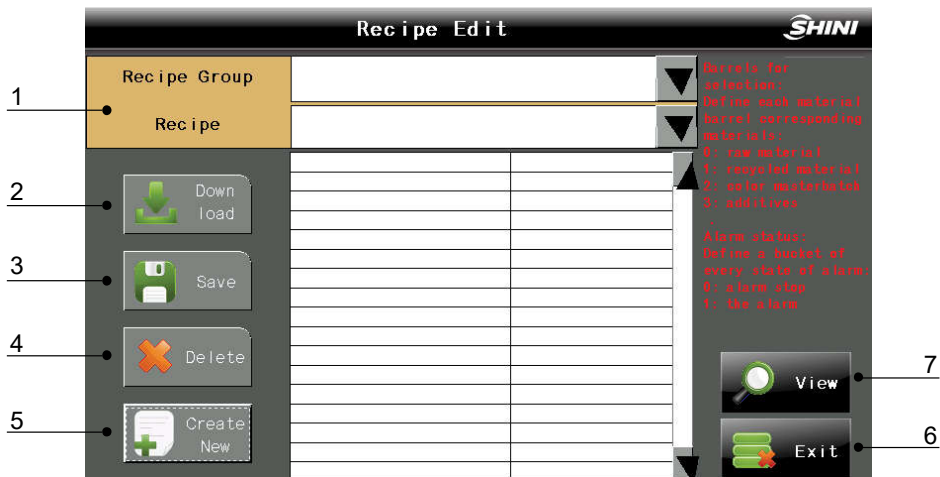

Picture 4-11: Recipe Setting Interface

User can manipulate the following contents in recipe setting interface:

Table 4-4: List of Formula Setting Screen

No.	Item	Description
1	Recipe information	Display the recipe information
2	Download the recipe	Download current data of recipe selection to PLC, and the mixed proportioning data is set according to the new recipe (invoke the recipe).

3	Save the recipe	Save the data of recipe modification
4	Cancel the recipe	Cancel the recipe data
5	Create new recipe	Create new recipe
6	Exit recipe editing	Exit recipe editing
7	Check	Check the editing status

4.5.6 Recipe Elements

Recipe includes the combination of related production data such as mixture proportion, etc. Mixture proportion will be transmitted from touch screen to PLC weighing mixing system for the convenience of converting from product A (for example) to product B. The weighing mixing system is able to manufacture products in categories of A, B and C, etc. with different mixture proportions and it is also able to create one recipe for each product. All necessary ingredients for each product are defined in recipe, which can store 100 groups of ingredients.

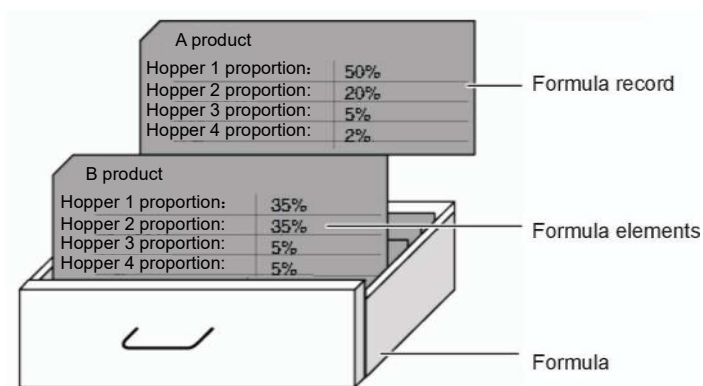

Picture 4-12: Recipe Elements

1) Recipe record

Each recipe stands for the recipe data record necessary for the production of one certain product.

2) Recipe elements

Each index card in one drawer includes application range of different ingredients and each application range corresponds with one recipe ingredient. Therefore, all records of one recipe include the same elements.

Nevertheless, the value of each element in different records differs.

No.	Recipe ingredients names	Meaning	New-built default value
1	Components of each hopper	Set material for each hopper: (Discharge order: 1→0→2→3) 0. Raw material	0

		<p>1. Recycled material 2. master-batch 3. Additive</p>	
2	Hopper 1 starved feeding alarm mode [0-1]	<p>When the computation mode for master-batch and additives adopts No. 2 (percentage relative to raw material), it is able to select hopper 1 starved feeding alarm mode by setting from 0 to 1 with the following definition: 0: Sound an alarm and stop the machine 1: Sound an alarm and stop the machine until it finishes the current batch. Note: When the computation mode for master batch and additive adopts No.1 (relative to batch percentage or No.3 computation mode (relative to double raw materials percentage), the mode election is invalid and the starved feeding will be uniformly given an alarm and stop the machine.</p>	0
3	Hopper 2 starved feeding alarm mode [0-2]	<p>When the computation mode for master-batch and additives adopts No. 2 (percentage relative to raw material), it is able to select hopper 2 starved feeding alarm mode by setting from 0 to 2 with the following definition: 0: Sound an alarm and stop the machine. 1: Sound an alarm without machine stop, replace it with hopper 1. 2: Neither alarm nor machine stop, replace it with hopper 1. Note: When the computation mode for master batch and additive adopts No.1 (relative to batch percentage or No.3 computation mode (relative to double raw materials percentage), the mode election is invalid and the starved feeding will be uniformly given an alarm and stop the machine.</p>	0
4	Percentage of each hopper [%]	<p>Set percentage for each hopper. Note: percentage of hopper 1 is automatically calculated by the formula.</p>	0.0
5	Given value of batch [kg]	<p>Set the mixture weight for processing in each period. 1、 use the following settings for reference: SGB-40 0.5kg SGB-80 1.5Kg SGB-200 2.5Kg SGB-600 8.0Kg SGB-1200 15.0kg SGB-2000 25.0Kg SGB-3000 40.0Kg 2、 If the degraded (reclaimed) materials cover high percentage and their specific gravity is smaller than 0.6Kg/dm³, then the volume of this</p>	0.0

		batch of mixture might exceed the volume of the weight pan and the mixture might overflow. At that time, the batch size should be reduced.	
6	Weight pan discharging time [second]	Set the discharging time of the mixture from the weight pan after gravimetry within each period. Set a suitable time in which the material can discharge completely from the weight pan.	0.0
7	Mixing time of the blender [second]	Set the working time for the blender in one period.	0.0
8	Mixed material discharging time [second]	Set the discharging time of the mixed material from the mixing tank within each period. Set a suitable time in which the material can discharge completely.	0.0
9	Chromatism compensation [%]	Set the compensation value of reclaimed materials.	0.0

4.5.7 Menu Interface

User shall press <menu> to enter menu selection interface under which operation items can be selected according to the needs.



Picture 4-13: Menu Selection

No.	Items	Description
1	Parameter setting button	Press this button to enter parameter setting menu.
2	Units setting button	Press it to enter unit setting interface.
3	Manual mode key	Press it once to enter manual mode interface.
4	User password key	Press it once to enter user management interface.
5	Display setting button	Press it to enter display setting button.
6	Weighing calibration menu	Press this button to enter weighing pan calibration menu.
7	Parameter initialization button	Press it at the first boot to initialize the parameter.
8	Save button	Press it after setting all the parameters and recipes to save the data and prevent losing it when there is power failure.

4.5.8 Parameter Setting Interface

Under menu selection interface, press <parameter setting> to enter parameter setting interface under which items of assembly mode, blender start mode and maximum weighing, etc. can be set.

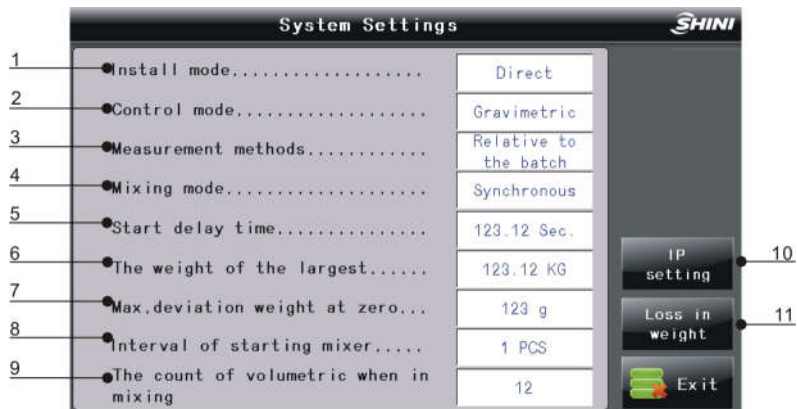

Picture 4-14: Parameter Setting Interface

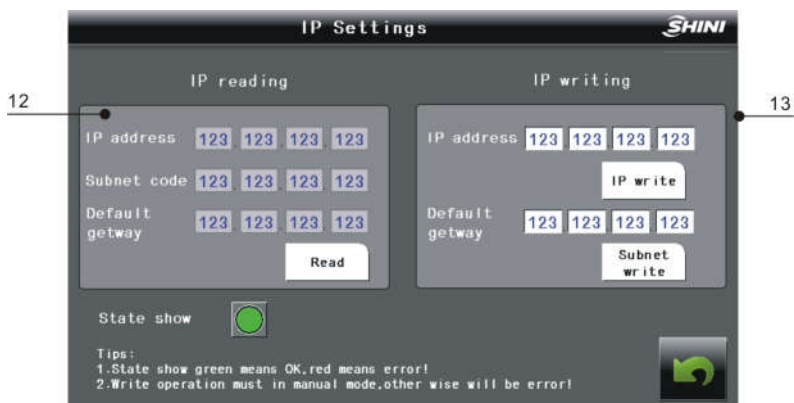

Picture 4-15: IP Setting Interface

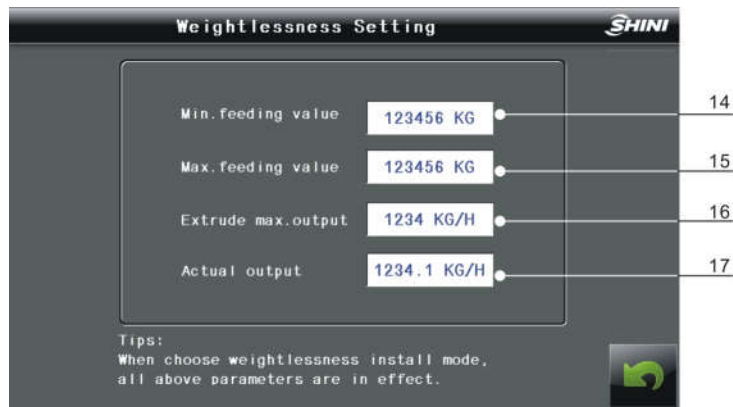

Picture 4-16: Weightlessness Parameter Interface

No.	Items	Description
1	Assembly mode	Three ways are available: direct installing, installing with floor stand and lost-in-weight installing. Direct installing: start/stop based on high material level signal of mixing hopper. With floor stand: feed material twice into mixing hopper and discharge than to storage hopper, whose high material level control start/stop. Lost-in-weight: discharge valve of mixing hopper is controlled by lost-in-weight hopper signal of material supply.
2	Control mode	Three modes are available: gravimetric metering, volumetric metering and mixing metering. More details please refer to appendix 8.
3	Metering method	There are three ways of measuring master-batch and additives : 1. Percentage relative to the batch 2. Relative to the material 3. Relative to double material More details please refer to appendix 3.
4	Mixing method	Synchro start: the blender starts working while the weighing pan starts discharging. Time-delay start: the blender starts working after the discharging of the weighing pan.
5	Delay time of startup	When machine is under automatic running condition, system will check the low-level of the storage hopper (optional). If level is low, system will begin to meter after the delay-time. If the level is high, system will stop metering and display a state of full material. Factory setting: 3 seconds.
6	Max. weighing volume	Setting of max. pan bearing weight. If the weight in pan is detected over the set value, machine halts and sounds alarm.
7	Pan zero drift weight	When the weight of empty weighing pan exceeds set point of max. zero drift weight, system will give an error information about the serious zero drift.

		Factory setting is 100g.
8	Mixing frequency	Set the delayed batch unloading of mixing hopper to make the first batch
9	Volumetric metering frequency under mixing metering mode	Under mixing metering mode, the times of volumetric metering.
10	IP setting	Press it to enter IP setting interface.
11	Weightlessness	Press it to enter lost-in-weight (when choosing the lost-in-weight hopper assembly) parameter setting interface.
12	IP display	In this area, the current IP address of PLC can be read.
13	IP type-in	In this area, the current IP address of PLC can be typed in. (Modification can be accepted when there is special needs.)
14	Min. feeding value	When choosing a lost-in-weigh hopper, start the weighing metering when the weight of the hopper is smaller than the min. feeding value.
15	Max. feeding value	When choosing a lost-in-weigh hopper, stop the weighing metering when the weight of the hopper is bigger than the min. feeding value.
16	Extrude max. output	According to the output of 10V, work out the analog amount of the current output.
17	Actual output	Display the current output.

4.5.9 Calibration Interface

Under menu selection interface, press < weight correction > to enter the calibration interface. All weighing units have been corrected in the manufacturing factories. The < zero > key is pure zero setting key (deduct tare weight). The transportation and/or operation (for example, the particles that remain in weight pan, or when the weight pan is placed on the weight-supporting stand) might cause minor difference. Nevertheless, the controller will execute the weight pan zero setting before each cycle.

When there is failure, calibration program must be executed when auditing or replacing with a new gravimetric sensor.

1. Weight correction



Picture 4-17: Calibration Interface

2. Steps:

- 1) Press full-scale calibration to enter the process, then hang the accessory weight under the weighting pan and input the weight to the system and at last, press calibration to automatically enter the next step.
- 2) Take down the weight and stabilize the weight pan, then press set zero to finish the calibration process.

4.5.10 User Management Interface

Under menu pwd interface, touch pwd to enter user management interface. Only users with the identity of administrator can execute operations such as adding new users, modifying users names and passwords, etc..

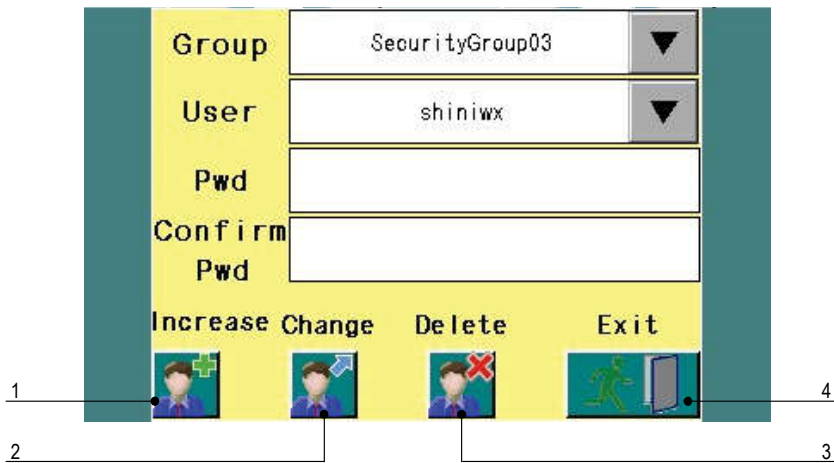

Picture 4-18: User Management Interface

Table 4-5: List of User Management Screen

No.	Item	Description
1	Increase	Press the group column and choose [SecurityGroup01] or [SecurityGroup02], then press user column and type in the user name that you want to create, and next input the passwords and confirm passwords, at last, press add a user and finish the process.
2	Modify	previous steps are similar as user increase (see: user increase), and the last step is to press the 【modify】 for user change.
3	Cancel	cancel the user
4	Exit	exit current operation

Note: It is important to write down the new user name and passwords when modifying a user. If you can't remember your user name and passwords, please contact SHINI customer service center.

4.5.11 Manual Mode Interface

Under menu selection interface, touch the <manual mode> to enter manual mode interface. User can manually manipulate all mechanical movement units in order to check if all functions work normally.

Note: Danger of causing injuries!

When compressed air supply is connected, if you touch the outlet or measuring unit of the mixture, it might injure your hands. No touching outlet or feeding & distributing units of the mixture.

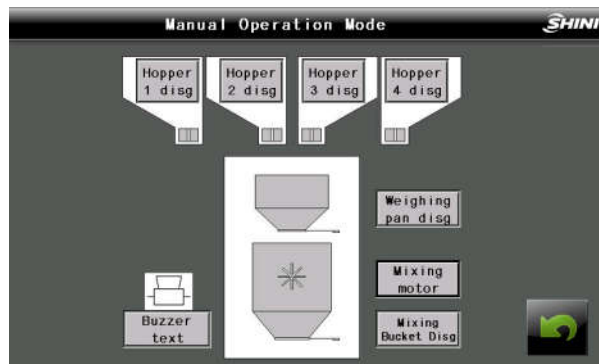

Picture 4-19: Manual Mode Interface

Table 4-6: List of Manual Mode Screen

Item	Description
Operation conditions	Safety door must be closed and air pressure must meet the requirements.
Check the metering units of each hopper	Check the metering units of each hopper Diagrams shown the hopper condition must located at the top of the interface. Press hopper discharge buttons one by one to check whether each hopper metering unit can open or close smoothly.
Check the weight pan, blender and the shut-off valve of the mixing tank.	Press the button besides the diagram to check whether the weight pan and the mixing elements is normal. Press the first button to open or close the weight pan. Press the button in the middle to start and stop the blender. Press the button blow to open or close the shut-off valve of the optional mixing tank.

Test the alarm and buzzer	Press Buzzer test to test the alarm and the buzzer which are installed on the electrical cabinet door.
------------------------------	---

Notice: Make sure all the components work normally.

4.5.12 Unit Parameter Setting Interface

Under menu setting interface, touch <unit setting> to enter unit setting interface. Unit parameters are set in the manufacturer and need no adjustment except when replacing a PLC controller.

Note: Random change of the parameter set in unit is prohibited. Otherwise, it will damage the machine!

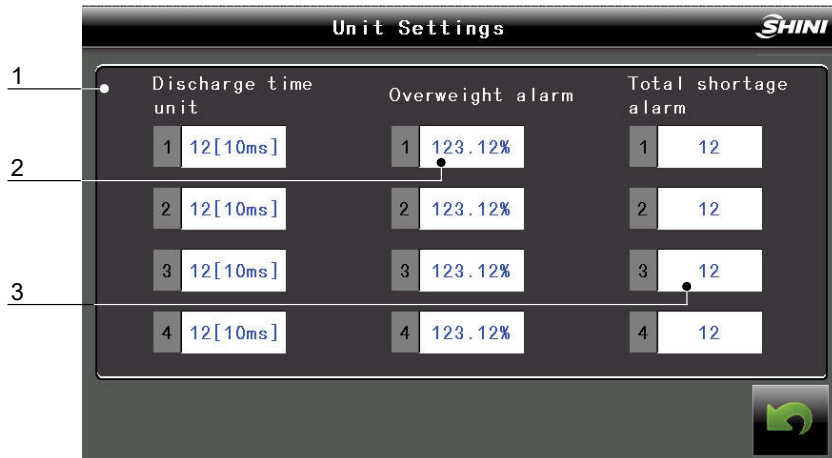

Picture 4-20: Unit Parameter Setting Interface

No.	Item	Description
1	Every hopper min. discharge time	System will complete the metering of certain barrel based on the parameters when it calculates the feeding precision of certain hopper (actual percentage minus set percentage). The following is ex-works setting: Air cylinder measuring valve is set at 0.3%. Bolt measuring valve and pulse measuring valve are set at 0.1% Remarks: the smaller the feeding precision data are, the higher the control precision is. Precision control might be unstable if feeding precision is less than the hardware limit of the measuring valve. The higher the feeding precision data are, the lower the control precision is. But the yield will also be promoted.
2	Every hopper value for alarm of over discharging	When the weight is bigger than the required weight value x over charging alarm value, give an alarm of over discharging.
3	Discharge hopper count alarm of lack of stuff	During the metering process, try to open the weighing unit several times when the weighing has no variation. Is there is still no variation, give an alarm of starved feeding.

4.5.13 Alarm Message Interface

Touch Alarm Message and enter alarm message interface under which the faults information can be viewed and the faults can be removed in time.

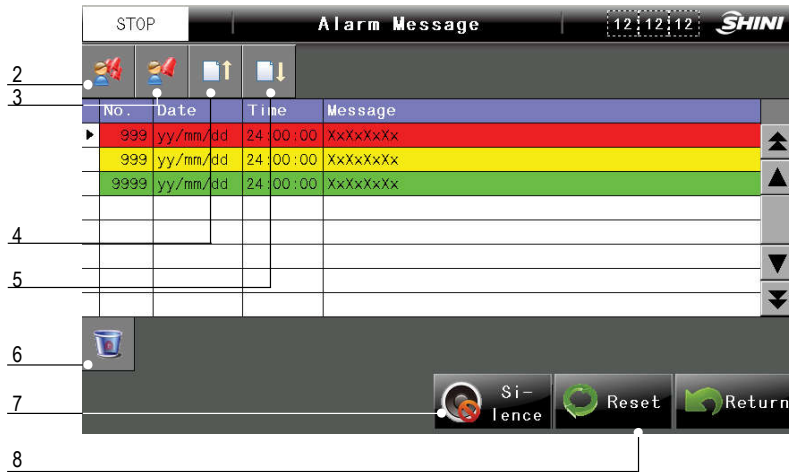

Picture 4-21: Alarm Message Interface

Table 4-7: List of Alarm Checking Screen

No.	Item	Description
1	Alarm information display	When the system fails, the content of corresponding fault information will be displayed that containing the date, time, state, and content of the failure.
2	Confirm all	Confirm all alarm information
3	Confirm one item	Confirm the single alarm information
4	Turn up	Pressing the turn up key, upper hidden information will be displayed.
5	Turn down	Pressing the turn down key, lower hidden information will be displayed.
6	Cancel alarm information	After selecting corresponding alarm information, press the 【cancel】 to delete the alarm information.
7	Mute	When it alarms, press 【Mute】 key, the alarming can stop immediately.
8	Reset	When it alarms, each information must be confirmed by the manual 【reset】 .

4.5.14 Control of Feeding

Before operating the control of automatic conveying, please connect the circuit part well by following the operation instruction and electrical control in this manual.

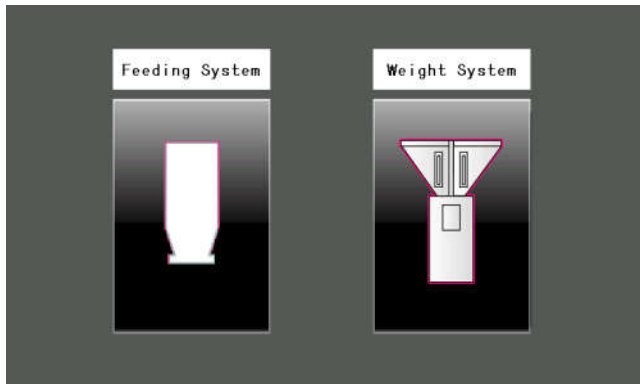

Picture 4-22: Selection Screen of Feeding System and Weight System

1. Enter into the selection screen of feeding system and weight system. Then press< Hopper> to enter into the feeding monitoring screen.

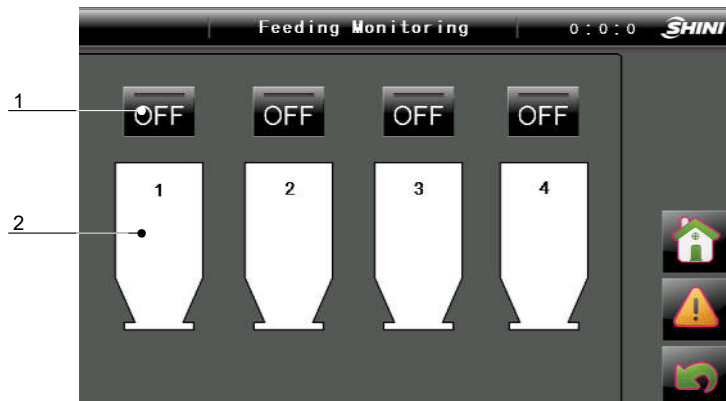

Picture 4-23: Feeding Monitoring Screen

Table 4-8: List of Feeding Monitoring Screen

No.	Name	Description
1	conveying switch	conveying switch
2	hopper icon	hopper icon identification

2. Press< Hopper> to enter into feeding parameters setting screen of each hopper. Parameters of hopper 1 to hopper 4 are set as the following:

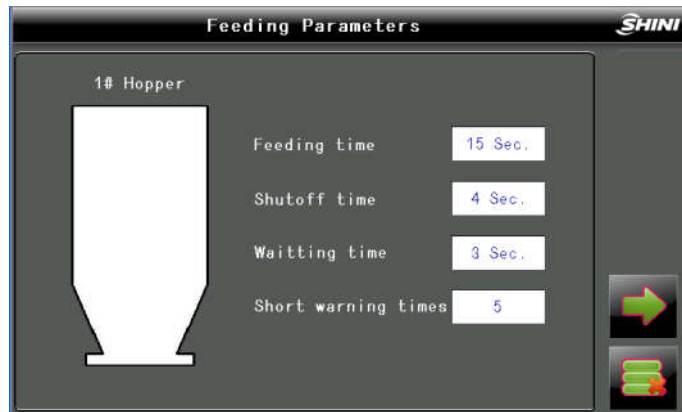

Picture 4-24: Feeding Parameters Screen

3. Go back to the feeding monitoring screen after finishing setting of feeding parameters of hopper 1 to hopper 4. Then press the feeding switch to make the system automatically complete the material suction cycle (No need to open hoppers which are not used.).

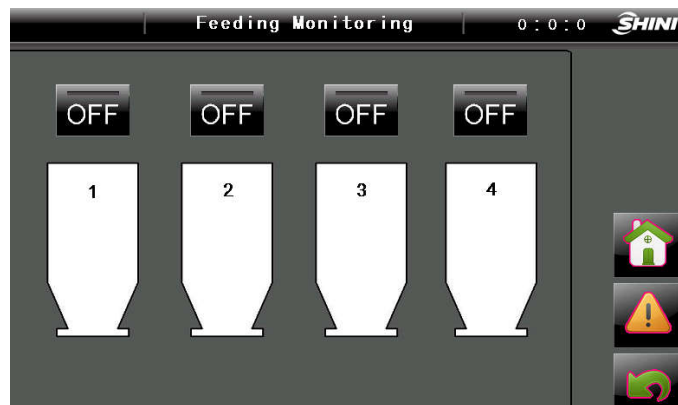

Picture 4-25: Feeding Monitoring Screen

4.6 Level sensor

4.6.1 Adjustment of Material Level Switch



Fig. 4-26: Level Sensor Adjustment

Table 4-9: List of Level Sensor Adjustment

No.	Item	Description
1	[OFF] programming key	When the material level reaches or is higher than the material level sensor, observe the indicator at the end of the level sensor, which should be on normally. If it is off, it means the sensor hasn't been adjusted well. Then, press on the [OFF] programming key for 6 secs. to complete the demonstration.
2	[ON] programming key	When the material level is lower than the level sensor, observe the indicator at the end of the level sensor, which should be off normally. If it is on, it means the sensor hasn't been adjusted well. Then, press on the [ON] programming key for 6 secs. to complete the demonstration.

Remark: If above state can't be adjusted, please check the wiring or replace the level sensor (Notes: wire line: signal line; blue line: is connected to 24V-; brown line: is connected to 24V+).

Notes: The gap between the level sensor of the mixing tank and the mixing tank should be adjusted within 3~6mm that can't exceed 8mm.

4.6.2 Functions of Each Level Switch

Level switch on hopper (optional)

- 1) It functions as pre-reminding the low level to give the operator enough time to load material.
- 2) The level switch on hopper 2 has another function when hopper 2 is recycling

material, and the raw material (hopper 1) shall take place of it automatically when the recycled material level is lower than this switch position.

- 3) When the recycled material level exceeds the position of switch again, hopper 2 recovers to unload the material.



Picture 4-27: Level Switch on Hopper

2) Level switch on Mixing Tank

It functions as inspecting the material level of mixing tank. The machine will stop the calculate circulation when the level is higher than this switch position and restart it until the level is lower this switch position.



Picture 4-28: Level Switch on Mixing Tank

3) Level switch on storage tank (only for model with a floor stand)

It functions as inspecting the material level of storage tank. The machine will stop the calculate circulation when the level is higher than this switch position and restart it until the level is lower than this switch position.



Picture 4-29: Level Switch on storage Tank

4.7 Components Instructions



Attention!

For application on the spot varies with the circumstances, new SGB allows each hopper freely defines its components categories. To operate the machine correctly, please read through this chapter carefully.

1. Eight components proportioning can be controlled at most.
2. Components categories of hopper 1~8 can be defined as follows:
 - Raw material;
 - Regrinds;
 - Master-batch;
 - additive;
3. Feeding sequence: Regrinds → Raw material → Master-batch → additive
(Components of the same kind will be feed from hopper 1 to hopper 8 in succession.)

4.7.1 Components category definition and distribution principle

1.Regrinds

Definition: recycled plastic granules with additives such as master-batch in it.

Distribution principle: relative to batch weight percentage

When a component is defined as regrinds, it is always calculated relative to batch weight percentage.

For example: if the batch weight is 1000g, and regrinds proportion is 20%, then regrind weight will be 200g.

2.Raw material

Definition: natural plastic particles without any additives in it.

Distribution principle: percentage relative to the total weight of raw material (percentage between materials.)

Description: hopper 1 is defined as raw material feeding and its percentage is automatically calculated. Total percentages of all the materials added together should be 100%.

When the component is defined as raw materials, it is always calculated relative to the proportion of each raw material. The actual batch weight proportion is relative to the proportions of regrinds and additives.

For example: batch weight is 1000g, hopper 3 is defined as 20% raw material and there is no regrinds or additives, calculation will be as follow:

$$\begin{aligned} \text{Hopper 1 (raw material) [AUTO]} &= 100\% - \text{Hopper 2 [set]} \\ &= 100\% - 20\% \\ &= 80\%; \end{aligned}$$

$$\text{Hopper 3 (raw material)} = 20\%;$$

$$\text{The relative proportion} = 80\% : 20\% = 4 : 1$$

Because there are no regrinds and additives, the batch is raw materials.

Therefore:

$$\text{Hopper 1 (raw material)} = 1000\text{g} \times 80\% = 800\text{g};$$

$$\text{Hopper 3} = 1000\text{g} \times 20\% = 200\text{g};$$

If Hopper is defined as 25% regrinds, calculation will be:

$$\text{Hopper 2 (regrinds)} = 1000\text{g} \times 25\% = 250\text{g};$$

$$\begin{aligned} \text{The total weight of the material} &= (\text{batch weight} - \text{regrinds weight}) \\ &= (1000\text{g} - 250\text{g}) = 750\text{g} \end{aligned}$$

$$\text{Hopper 1 (raw material)} = 750\text{g} \times 80\% = 600\text{g};$$

$$\text{Hopper 3 (raw material)} = 750\text{g} \times 20\% = 150\text{g};$$

The proportion between materials = (600 : 150) = 4 : 1 (no change of material relative proportion)

3.Material Additives

Definition: A substance to be proportionally added to raw materials. Such as master-batch, stabilizer, et..

Distribution Principle: percentage relative to the total weight of all the materials.
For example when hopper 4 is defined as 5% additives, calculation will be as below according to the above-mentioned example:

$$\text{Hopper 2 (regrinds)} = 1000\text{g} \times 25\% = 250\text{g};$$

$$\begin{aligned} \text{The total weight of raw material and additives} &= (\text{batch weight} - \text{regrinds weight}) \\ &= (1000\text{g} - 250\text{g}) = 750\text{g} \end{aligned}$$

$$\text{Hopper 1 (raw material)} = (750\text{g}/105\%) \times 80\% = 571.4\text{g};$$

$$\text{Hopper 3 (raw material)} = (750\text{g}/105\%) \times 20\% = 142.9\text{g};$$

$$\begin{aligned} \text{Hopper 4 (additives)} &= (\text{hopper 1} + \text{Hopper 3}) \times 5\% \\ &= (571.4\text{g} + 142.9\text{g}) \times 5\% \\ &= 35.7\text{g} \end{aligned}$$

Proportion between materials = (571.4: 142.8)=4: 1 (no change of material relative Proportion)

4.8 Calculation Method of Master-batch and additives

There are three methods to calculate master-batch and additives:

1. Relative to batch capacity;

Ratios of master-batch and additive are calculated relative to batch capacity.

E.g.: BATCH=1.0Kg, Hopper 1=AUTO calculated, Hopper 2=40%,

Hopper 3=3%, Hopper 4=2%. Thus real weights are:

Hopper 1=1.0 × (100%-40%-3%-2%)=0.55Kg(550g)

Hopper 2=1.0 × 40%=0.4Kg(400g)

Hopper 3=1.0 × 3%=0.03Kg(30g)

Hopper 4=1.0 × 2%=0.02Kg(20g)

2. Relative to raw material capacity;

Ratios of master-batch and additive are calculated relative to raw material capacity.

E.g.: BATCH=1.0Kg, Hopper 1=AUTO calculated, Hopper 2=40%,

Hopper 3=3%, Hopper 4=2%. Thus real weights are:

Hopper 1=1.0 × (100%-40%)=0.6Kg(600g)

Hopper 2=1.0 × 40%=0.4Kg(400g)

Hopper 3=0.6 × 3%=0.018Kg(18g)

Hopper 4=0.6 × 2%=0.012Kg(12g)

Under this mode, weight of both master-batch and additives will be adjusted automatically depending on the availability of regrind (Hopper 2). Take above as example: as long as regrind in hopper 2 is full, amount of master-batch (Hopper 3) and additives (Hopper 4) will always be 18g and 12g respectively. But, if regrind is not available or its level is low, raw material in Hopper 1 will replenish the difference automatically, therefore, real weights of master-batch and additives will be:

Hopper 3=1.0 × 100% × 3%=0.030Kg(30g)

Hopper 4=1.0 × 100% × 2%=0.020Kg(20g)

3. Relative to double raw material capacity;

Ratios of master-batch and additive are calculated relative to double raw material (Hopper 1 + Hopper 2) capacity.

E.g.: BATCH=1.0Kg, Hopper 1=AUTO calculated, Hopper 2=40%,

Hopper 3=3%, Hopper 4=2%. Thus real weights are:

Hopper 1=1.0 × (100%-40%)=0.6Kg(600g)

Hopper 2=1.0 × 40%=0.4Kg(400g)

Hopper 3=(0.6+0.4) × 3%=0.03Kg(30g)

Hopper 4=(0.6+0.4) × 2%=0.02Kg(20g)

4.8.1 Appendix 4: Chromatic Aberration Compensation of Reclaimed Material

In some occasions, the color of reclaimed material may fade. Therefore, it is necessary to add master-batch.

E.g.: reclaimed material=600g, raw material=1400g,

proportion of master-batch=4%

If the compensation value of reclaimed material is 0:

Master-batch=raw material × master-batch proportion= 1400 × 0.04= 56g

If the compensation value of reclaimed material is + 20%:

Used master-batch = (raw material + reclaimed material × 20%) × master-batch proportion = (1400 + 600 × 0.2) × 0.04= 60g

4.8.2 Appendix 7: Blending Motor Locked-rotor Inspection Switch

It is used to detect whether the blending motor is blocked up and protect the blending motor effectively. Pay attention to the tail indicator of this inspection switch which shall glitter during the blending motor operation. The inspection switch may be broken or installed improperly if the indicator is not glittering.

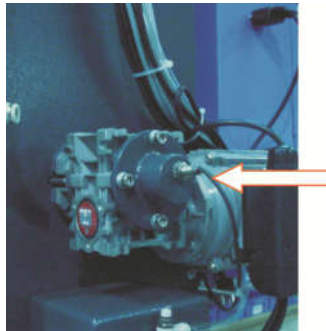

Picture 4-30: Blending Motor Locked-rotor Inspection Switch

4.9 Control Mode

There are three modes of metering controlling:

Table 4-10: List of Metering Control Mode

No.	Item	Description
1	Weighing metering mode	Each ingredient can be proportioned by metering the weighing sensor (normal mode is recommended).
2	Volume (time) metering mode	Each ingredient can be proportioned by time setting (When the weighing sensor fails, start the emergency standby mode).
3	Mixed metering mode	After the weighing metering cycle, the next is the volume metering cycle with adjustable cycle times (For the occasions without high proportional accuracy demands, it is used for improving the hourly handling capacity).

4.9.1 Weighing Metering Mode

This mode is the accurate metering and with this mode, proportion of every component is measured and controlled via weighing cell. Below is the principle:

1. Based on the batch feeding percentage, reclaims are measured by weighing cell and then they fall in the pan.
2. Total material weight will be come out based on reclaim actual feeding amount. Each component will be weighed by weighing cell according to material total weight and fall in the pan.
3. Master-batch will be metered according the selected metering method.
4. Additives will be metered according the selected metering method.
5. After four components above are metered, pan opens and mixture will fall into mixing hopper for uniform blending.
6. Mixing period is over and discharge valve opens to allow mixture to be loaded to storage hopper.

In the weighing metering mode, total material usage varies with changes of reclaim actual weight, material additive usage varies with changes of actual material usage, and batch additive varies with changes of whole batch weight. Thus, actual feeding amount of components of each batch is adjusted automatically, which ensures a stable and accurate proportioning.

4.9.2 Volumetric (Time) Metering Mode

This mode is an emergency mode, which only comes into effect during weighing

system failing to work or other special situations. Below is the principle:

1. First step, metering cell of reclaims conducts volumetric metering based on time setting of the current mode;
2. Second step, metering cell of raw material conducts volumetric metering based on time setting of the current mode;
3. Third step, metering cell of material additives conducts volumetric metering based on time setting of the current mode;
4. Fourth step, metering cell of batch additives conducts volumetric metering based on time setting of the current mode;
5. After four metering above are finished, pan opens and mixture will fall into mixing hopper for uniform blending.
6. Mixing period is over and discharge valve opens to allow mixture to be loaded to storage hopper.

Under volumetric metering mode, weighing cell is unavailable for using and metering is under time fuzzy control. Thus material in each hopper should be sufficient for proportioning would go wrong if shortage of material exists in this mode. Hopper low level switch is available as an option to early warn the proportioning error.

4.9.3 Mixing Metering Mode

In this mode, when a batch is completed via weight metering mode, then up to 8 volumetric metering modes can be added. (Cycles is adjustable). Thus throughput per hour of machine can be increased via reducing weighing times while mixing accuracy may be lowered.

5. Trouble-shooting

SGB-40~600

Alarm information	Results	Possible reasons	Solutions
Hoppers1~4 low level	Alarm	<ol style="list-style-type: none"> 1. No material inside the hopper. 2. Level sensor wasn't adjusted properly. 	<ol style="list-style-type: none"> 1. Add material into hopper. 2. Adjust the sensitivity of sensor.
Hoppers 1~4 shortage	Alarm and stop the machine	<ol style="list-style-type: none"> 1. No material in the hopper. 2. Metering valve is blocked or motor failure. 3. Electro-circuit or pneumatic lines fault. 4. Weighing system faults. 	<ol style="list-style-type: none"> 1. Check the material in the hopper. 2. Check metering valve and motor. 3. Check electro-circuit or pneumatic lines. 4. Check whether the weighing works normally on the weighing calibration menu.
Hoppers 1~4 over weight	Alarm	<p>The volume of discharged material exceeds the overloading alarm setting value.</p> <ol style="list-style-type: none"> 1. Metering valve cannot be closed. 2. New controller doesn't carry out weighing calibration. 3. The overloading setting value is too small. 4. Setting proportion is too small. Small proportion isn't suitable for pneumatic metering. 5. Sometimes, it's normal for the first time startup of machine. 	<ol style="list-style-type: none"> 1. Check the metering valve. 2. Carry out the weighing calibration. 3. Set the proportion for 5%-10%. 4. Exchange with screw metering device.
Load cell failure	Alarm and stop the machine	Circuit faults or pressure is too high.	<ol style="list-style-type: none"> 1. Check if there is a load in the weighing pan. 2. Check the weighing sensor. 3. Check if the lines break. 4. Calibrate the weight again.
Output reached	Alarm and stop the machine	Reach the estimated output	<ol style="list-style-type: none"> 1. Set a new output vale or input '0' to close this function. 2. After 'clear accumulation', machine will start with a new work cycle0
Over weighing pan	Alarm and stop the machine	The weight of discharged material exceeds the alarm setting value of weighing pan.	<p>Check if all metering valves/motors work normally.</p> <ol style="list-style-type: none"> 1. Check if there is other heavy load in the weighing pan or weighing pan has been pressed deadly. 2. Overloading alarm setting value is too small. Please refer to parameter setting menu3.
Mixing motor failure	Alarm and stop the machine	During mixing, no rotation action of mixing motor is detected.	<ol style="list-style-type: none"> 1. Check whether this motor works normally. 2. Check whether the motor sensor is adjusted correctly.

Safety door / low pressure	Alarm and stop the machine	Safety door isn't closed or the pressure isn't enough.	<ol style="list-style-type: none"> 1. Check whether the safety door is closed tightly. 2. Check whether the air pressure is enough.
Module failure	Alarm and stop the machine	The red light of load cell SF is blinking which indicates the load cell or hardware faults.	<ol style="list-style-type: none"> 1. Check the connection of load cell is OK or not. 2. Check/change the load cell.
Pan or cell failure	Alarm and stop the machine	When system is under metering condition, the metered weight is decreasing.	<ol style="list-style-type: none"> 1. Check whether the weighing pan is closed tightly. 2. Check whether the connection of load cell is broken.
Deviation at "zero"	Alarm and stop the machine	System detects that the weight of empty weighing pan exceeds the alarm setting value of zero drift. Factory setting is +/-50g.	<ol style="list-style-type: none"> 1. Check the weighing pan can be opened freely or not. 2. Check whether the installation of load cell is correct. 3. Check whether the discharging setting time is too short (3-5s). 4. Check the metering valve of hopper 1 to hopper and see if it can be closed or opened freely to ensure no material leakage.
Module power failure	Alarm and stop the machine	Power supply of load cell disappears.	Check 24V DC power supply of load cell works normally or not.
Hopper 1 replaces hopper 2	Only display this information	When the low material (recycled material) occurs in hopper2, its proportion will be replaced by hopper 1.	

SGB-2000/3000

Alarm information	Results	Possible reasons	Solutions
Hopper1~8 low level of material	Alarm	<ol style="list-style-type: none"> 1. No material in hopper. 2. No adjusting level sensor. 	<ol style="list-style-type: none"> 1. Filling material. 2. Adjust sensor sensitivity.
Hopper1~8 material shortage	Alarm of machine halt	<ol style="list-style-type: none"> 1. No material in hopper. 2. Stuck of metering valve or motor faults. 3. Electric or air circuit faults. 4. Weighing system faults. 	<ol style="list-style-type: none"> 1. Check material in hopper. 2. Check the valve and motor. 3. Check electric or air circuit. 4. In weight calibration interface, check if weighing is normal.
Hopper1~8 overfeeding of material	Alarm	<p>Feeding amount exceeds hopper1~4 overweigh set valve of parameter setting.</p> <ol style="list-style-type: none"> 1. Metering valve can't be closed. 2. No weighing calibration of new controller. 3. Too small set value of overweight alarm. 4. Too small proportion setting. <p>Pneumatic metering valve</p>	<ol style="list-style-type: none"> 1. Check the valve. 2. Execute weighing calibration. 3. Set the value of 5%~10%. 4. Changed for screw metering.

		can't fit small proportion. 5. First startup, it is a normal situation.	
Off line of weighing sensor	Alarm of machine halt	Off line of weighing gauge or over pressure.	<ol style="list-style-type: none"> 1. Check if there is heavy object in pan. 2. Check the sensor. 3. Check if there is offline in circuit. 4. Recalibrating of weight.
Reach to the throughput	Alarm of machine halt	Set the reach to throughput.	<ol style="list-style-type: none"> 1. Set a new throughput value or input "0" to disable function. 2. Clear total value and startup, a new metering can be available.
Overweight of pan	Alarm of machine halt	Feeding weight exceeds pan overweight alarm setting.	<p>Check if metering valve and motor works normally.</p> <ol style="list-style-type: none"> 1. Check if heavy objects in pan or if pan gets stuck. 2. Too small overweight alarm setting. Refer to parameter setting screen 3.
Mixing motor faults	Alarm of machine halt	When agitating, mixing rotation of motor can't be detected.	<ol style="list-style-type: none"> 1. Check if mixing motor works normally. 2. Check if mixing motor sensor is adjusted accurately.
Safety door open or low pressure	Alarm of machine halt	No close of safety door or insufficient pressure.	<ol style="list-style-type: none"> 1. Check id the door is locked tightly. 2. Check if pressure is insufficient or not.
Weighing module faults	Alarm of machine halt	SF light is On, indicating module system or hardware faults.	<ol style="list-style-type: none"> 1. Check if weighing sensor is connected normally. 2. Check or replace weighing module.
Pan or sensor faults	Alarm of machine halt	When system is weighing, it detects weight is reducing.	<ol style="list-style-type: none"> 1. Check if pan is closed tightly. 2. Check if weighing sensor wiring if off or broken.
Pan seriously zero deviation	Alarm of machine halt	It detects weight of empty pan exceeds zero deviation alarm setting. Default value is +/-100g.	<ol style="list-style-type: none"> 1. Check if pan can be opened freely. 2. Check if there is any flaw in sensor installation. 3. Check if feeding time is too short. (3~5 seconds.) 4. Check if hopper1~4 metering valve can be opened/closed normally to ensure no material leakage.
Phase sequence error	Alarm of machine halt	Power wiring phase sequence error or default phase.	Check power wiring connection and exchange two wires at random.
Outage of weighing module	Alarm of machine halt	Power supply of weighing module fails	Check if module 24DC power supply is normal.

6. Maintenance and Repair

6.1 Maintenance

All the repair work should be done qualified personnel to prevent personal injuries and damage of the machine.

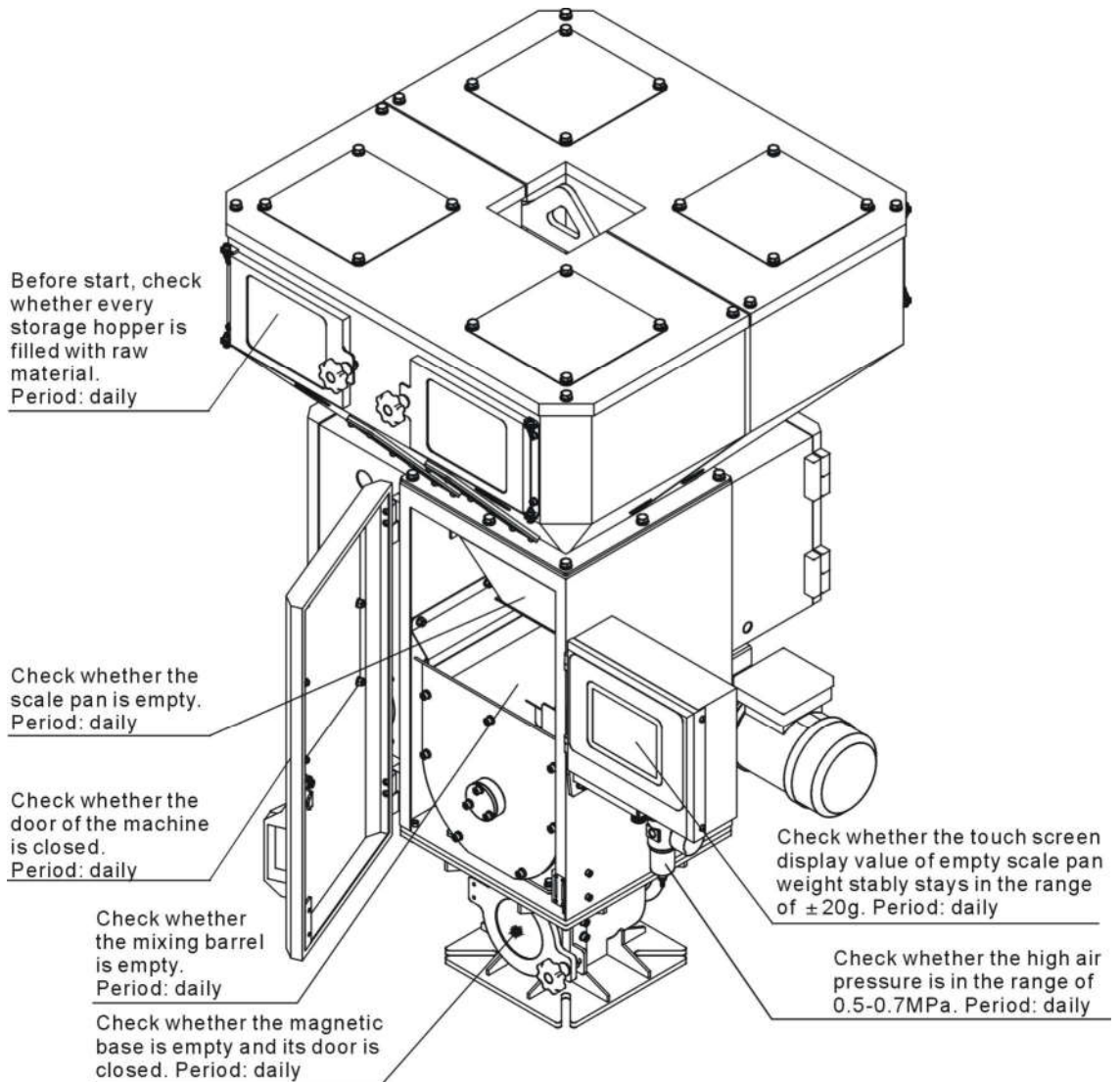

6.2 Filter & Pressure Regulating Valve

6.2.1 Filter & Pressure Regulating Valve Drawing

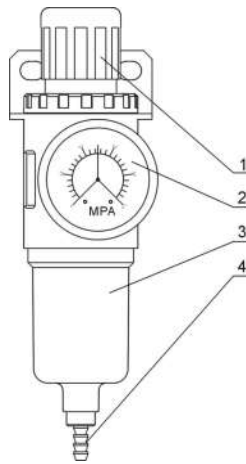

Parts list:

1. Pressure adjusting knob 2. Pressure gauge 3. Cup 4. Water outlet

Picture 6-1: Filter & Pressure Regulating Valve Drawing

6.2.2 Filter & Pressure Regulating Valve Operation steps

- 1) Switch on the air source.
- 2) Pull the black pressure adjusting knob 1 upward and rotate it, observe the pressure gauge 2, generally a 0.5 Mpa pressure is advisable.
- 3) Push back the black knob 1.

6.3 Storage Hopper Cleaning

- 1) Start the machine and enter the manual mode, open all the metering valves and shut-off plates.
- 2) Unscrew the screw and open the clearance door of the storage hopper.
- 3) Clean the storage hopper with a high pressure air gun.

6.4 Scale Pan Cleaning

- 1) Open the shut-off plates in manual mode.
- 2) Move the gravimetric hopper.
- 3) Clean the scale pan with a high pressure air gun.

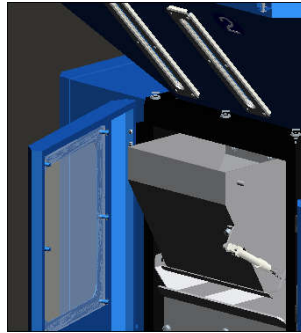

Picture 6-2: Drawing of Scale Pan Cleaning

6.5 Clean Mixing Chamber

Open the door of the machine and clean the inside with an air gun.

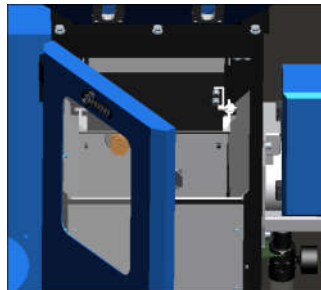

Picture 6-3: Clean Mixing Chamber

6.6 Magnetic Base Cleaning

- 1) Unscrew the cover of the discharging tube.
- 2) Unscrew the screw; open the door of the magnetic base.
- 3) Take out the magnet bar and remove the metal on it.
- 4) Clean the inside magnetic base with a high pressure air gun.

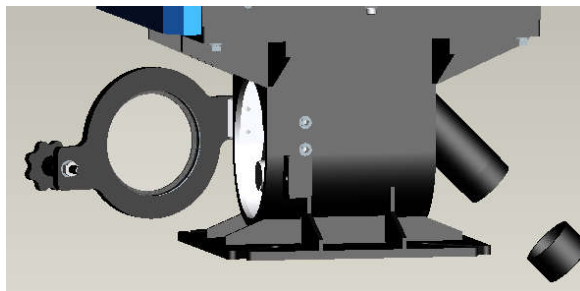

Picture 6-4: Drawing of Magnetic Base Cleaning

6.7 Clean Material Shut-off Plate

In order not to obstruct material discharging, please clean machine base and material shut-off plate of it regularly.



Picture 6: Clean Material Shut-off Plate

6.8 Maintenance Schedule

6.8.1 About the Machine

Model _____ SN _____ Manufacture date _____

Voltage _____ Φ _____ V Frequency _____ Hz Power _____ kW

6.8.2 Check after Installation

- Check the pressure of air supply
- Check that door security switch is tightly fixed
- Check if machine base is firmly locked or not

Electrical installation

- Voltage: _____ V _____ Hz
- Fuse melt current: 1 Phase _____ A 3 Phase _____ A
- Check phase sequence of power supply.

6.8.3 Daily Checking

- Check the power switch.
- Check the pressure of air supply.
- Check material discharge gate at machine base.
- Check fastening screws of machine base.

6.8.4 Weekly Checking

- Check all the electrical wires.
- Check all the electrical connections.
- Check the status of compressed-air filter & regulator.

6.8.5 Monthly Checking

- Check the performance of capacitor switch.
- Check the blending shaft.
- Check the performance of safety switch.