

STM-607W	版本	Ver.G
STM-607MW	版本	Ver.F
STM-607WA	版本	Ver.F

D	制图	版号	J	标题	STM-607W	图号	STM-607W-CE-400V-J-1	比例	第 1 张
	设计	核准		主电路图			标准	CE	共 6 张
	校对	日期	20230114		信易电热机械股份有限公司 Shini Plastics Technologies, Inc.	机器电压	3φ400V		
	标记	更改前	更改后			更改人	日期	机器频率	50Hz

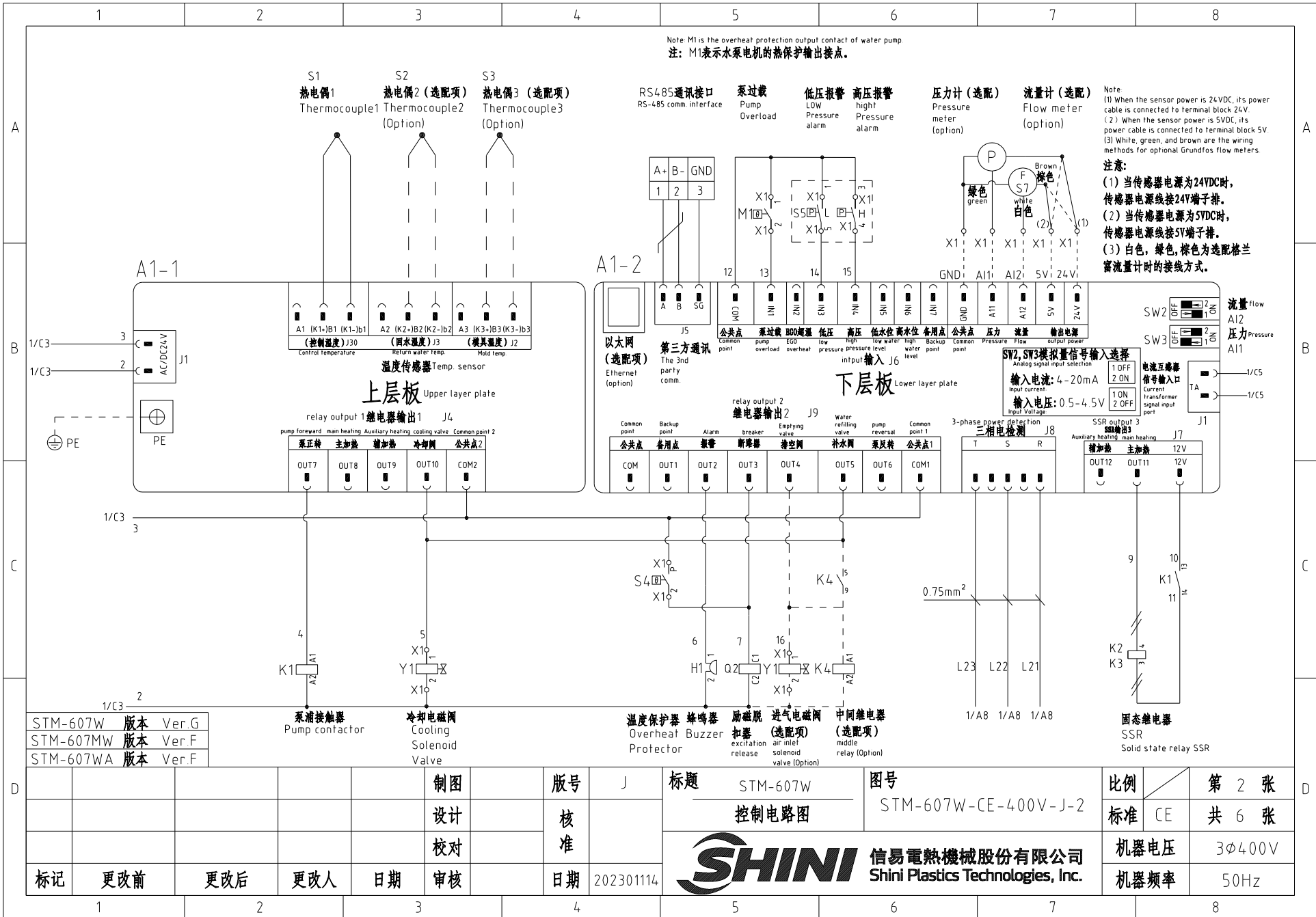

Note: M1 is the overheat protection output contact of water pump
注: M1表示水泵电机的热保护输出接点。

- RS485 通讯接口 RS-485 comm. interface
- 泵过载 Pump Overload
- 低压报警 LOW Pressure alarm
- 高压报警 high Pressure alarm
- 压力计 (选配) Pressure meter (option)
- 流量计 (选配) Flow meter (option)

Note:
(1) When the sensor power is 24VDC, its power cable is connected to terminal block 24V.
(2) When the sensor power is 5VDC, its power cable is connected to terminal block 5V.
(3) White, green, and brown are the wiring methods for optional Grundfos flow meters

- 注意:
(1) 当传感器电源为24VDC时, 传感器电源线接24V端子排。
(2) 当传感器电源为5VDC时, 传感器电源线接5V端子排。
(3) 白色, 绿色, 棕色为选配格兰流量计时的接线方式。

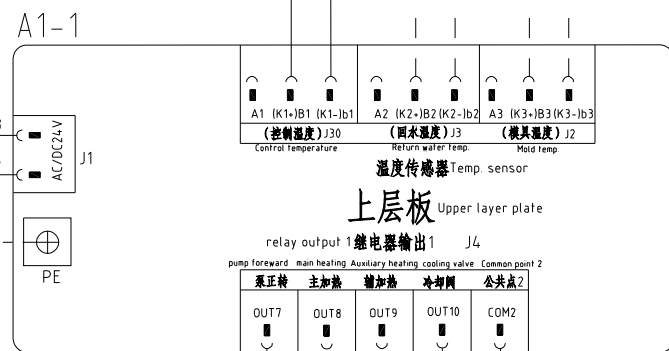
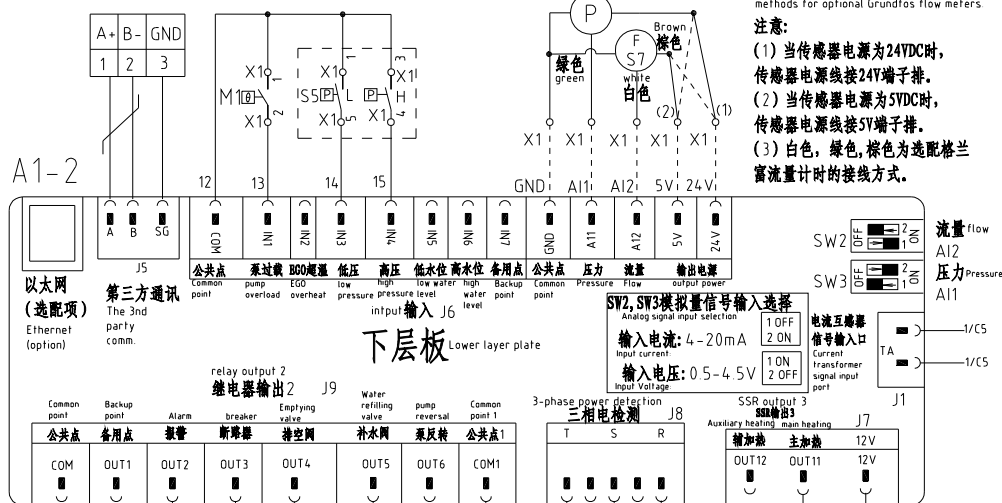

STM-607W	版本	Ver.G
STM-607MW	版本	Ver.F
STM-607WA	版本	Ver.F

		制图	版号	J	标题	STM-607W	图号	STM-607W-CE-400V-J-2	比例	第 2 张	
		设计	核准		控制电路图				标准	CE	
		校对	核准						机器电压	3φ400V	
标记	更改前	更改后	更改人	日期	审核	日期	202301114	SHINI 信易电热机械股份有限公司 Shini Plastics Technologies, Inc.		机器频率	50Hz

信易辅机RS-485通讯接线示意图

Shini auxiliary machine RS-485 comm. wiring diagram

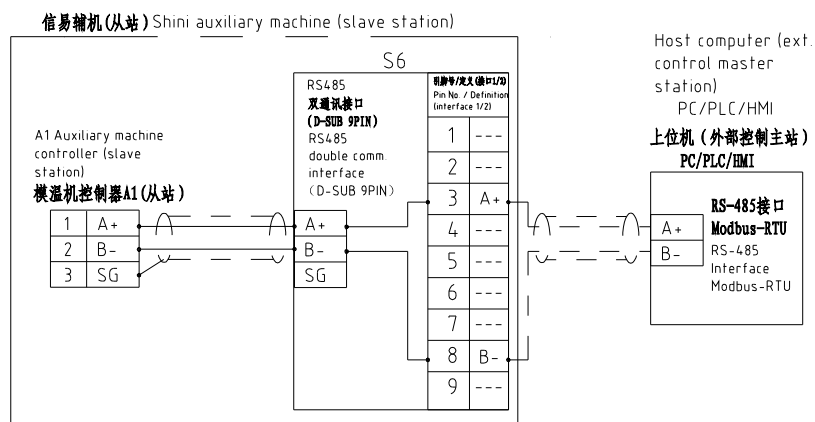

信易RS-485接口定义

Shini RS-485 interface definition

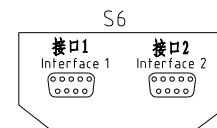

D-sub-9母接口 D-sub-9 pin interface	引脚号 Pin No.	引脚定义 Pin definition
	1	-
	2	-
	3	A+ (RS-485 信号) A+ (RS-485 signal)
	4	-
	5	-
	6	-
	7	-
	8	B- (RS-485 信号) B- (RS-485 signal)
	9	-

- 注: 1. 通讯接口: RS-485 (两线式)
2. 通讯协议: Modbus-RTU
3. 机器配备D-sub9母接头, 接口1和接口2内部并联, 功能相同, 不分主次;

Note:
1. Comm. interface: RS-485 (two wire)
2. Comm. protocol: Modbus-RTU
3. The machine is equipped with D-sub9 female connector; interface 1 and interface 2 are connected in parallel and have the same function, which is regardless of primary and secondary

STM-607W	版本	Ver.G
STM-607MW	版本	Ver.F
STM-607WA	版本	Ver.F

						制图	版号	J	标题	STM-607W	图号	STM-607W-CE-400V-J-3	比例	第 3 张
						设计	核		通讯接线图		标准	CE	共 6 张	
						校对	准			信易電熱機械股份有限公司		机器电压	3φ400V	
标记	更改前	更改后	更改人	日期	审核	日期	202301114			Shini Plastics Technologies, Inc.	机器频率	50Hz		

1		2		3		4		5		6		7		8	
序号/NO	符号/Symbol	名称/Name		制造商/Manufacturer		型号/Type		规格/Specification		单位/unit	数量/Number	物料编号/Material number		备注/Remark	
1	Q1	主电源开关/Main power Switch		EATON		TO-2-1/EA/SVB		20A		PCS	1.000	YE10021160000			
2	Q2	断路器/Circuit Breakers		TECO		BM-63C/3016S		16A		PCS	1.000	YE40301603000			
3		励磁脱扣器/Excitation release		TECO		MX		24VAC		PCS	1.000	YE40024000000			
4	Q3	断路器/Circuit Breakers		TECO		BM-63C/2003S 2P		3A		PCS	1.000	YE40200203000			
5	Q4	断路器/Circuit Breakers		TECO		BM-63C/1003S 1P		3A		PCS	1.000	YE40100203000			
6	K1	接触器/Contactors		SIEMENS		3RT6016-1AB01		24VAC		PCS	1.000	YE00601602500			
7	K2 K3	固态继电器/Solid-State Relay		FOTEK		KSR-40DA-H		40A/480VAC/4-32VDC		PCS	2.000	YE03404003200			
8	K4	中间继电器/middle relay		HONEYWELL		GR-2C-AC24V		24VAC		PCS	1.000	YE03022400300		(4)	
9	T	互感器/Sensor Transformer		JIUXIN		IN=400V/415V OUT=24V		80VA		PCS	1.000	YE70040006500			
10	S6	通信接口板RS-485 (双Dsub-9pin接头) Communication interface board RS-485 (double Dsub-9pin connector)		YUYUN		----		----		PCS	1.000	YR40048500000			
11		外壳RS485 (SAL-700G-A-19) 0版 Shell RS485 (SAL-700G-A-19) 0		BINCHENG		----		----		PCS	1.000	YE84003500600			
12	A1	线路板/Circuit Board		PUNP		STM-O/-W(24VAC)		SF518501A.03		ST	1.000	YE81245100100			
13	H1	蜂鸣器/Buzzer		JINGKANG		PK-35A		24VAC/DC		PCS	1.000	YE60002503200			
14	X1	端子排/Terminal Board		HONEYWELL		SK2.5		2.5mm ²		PCS	13.000	YE60002503400			
15		接地端子排/Grounding terminal board		HONEYWELL		SK2.5PE		2.5mm ² PE		PCS	7.000	YE60002503200			
16		端子排/Terminal Board		HONEYWELL		SK4		4mm ²		PCS	6.000	YE60000403200			
17		接地端子排/Grounding terminal board		HONEYWELL		GK5PE		5mm ² PE		PCS	2.000	YE60000403500			
18	X2	端子排/Terminal Board		HONEYWELL		SK2.5		2.5mm ²		PCS	2.000	YE60002503400		(4)	
19		接地端子排/Grounding terminal board		HONEYWELL		SK2.5PE		2.5mm ² PE		PCS	1.000	YE60002503400		(4)	
20		接地端子排/Grounding terminal board		HONEYWELL		SK2.5PE		2.5mm ²		PCS	5.000	YE60000003900		(5)	
21		终端固定件E/GR系列(霍尼韦尔) Terminal fittings E/GR series(honeywell)		HONEYWELL		----		----		PCS	6.000	YE60000003900			
22		铝散热器 aluminum cooler		SHINI		----		----		BA	1.000	YW90120700000			
23	TA1	单电流互感器 Single current transformer		PUNP		IGW122C		1		PCS	1.000	YE04012204400			
24	S1	热电偶/Thermocouple		SHINI		----		K		PCS	1	----		(1)	
25	S2 S3	热电偶/Thermocouple		SHINI		----		K		PCS	2	----		(1)(2)	
STM-607W 版本 Ver.G		STM-607MW 版本 Ver.F		STM-607WA 版本 Ver.F		注: (1)表示带磁泵材料; (2)表示电加热器和出水温度显示功能; (3)表示电加热器泵; (4)表示电加热器回水及水出口温度显示功能; (5)表示电加热器清洗功能。 Notes: (1)Means it's not the material inside the control box. (2) Stand for optional return water and water outlet temperature display function. (3)Means equipped with magnetic pump. (4)Means optional air-blowing cleaning function. (5) Optional flow meter and pressure meter.									
				制图		版本号 J		标题 STM-607W		图号		比例		第 5 张	
				设计		核准		电气元件明细表一		STM-607W-CE-400V-J-5		标准 CE		共 6 张	
				校对				 信易电热机械股份有限公司 Shini Plastics Technologies, Inc.		机器电压		3φ400V			
标记		更改前		更改后		更改人				日期		202301114		机器频率	
1		2		3		4		5		6		7		8	

1		2		3		4		5		6		7		8		
序号/NO	符号/Symbol	名称/Name		制造商/Manufacturer		型号/Type		规格/Specification		单位/unit	数量/Number	物料编号/Material number		备注/Remark		
26	S4	超温保护器/Overheat Protector		----		----		----			1	----		(1)		
27	S5	高低压开关/Hi-Lo pressure switch		---		----		----			1	----		(1)		
A	28	S7	流量计/Flowmeter		CRUNDFOS		VFS QT 2-40		2-40L/min			1	----		(1)(5)	
	29	Y1	电磁阀/Solenoid Valve		----		----		24VAC			1	----		(1)	
	30	Y2	电磁阀/Solenoid Valve		----		----		24VAC			1	----		(1)(4)	
	31	M1	马达/Motor		SHINI		TP-55		400V 50Hz 0.55kW			1	----		(1)	
	32	M1	马达/Motor		SHINI		MP-55		400V 50Hz 0.55kW			1	----		(1)(3)	
	33	EH	电热/Heater		SHINI		----		400V 50Hz 6kW			1	----		(1)	
Notes: (1)Means it 's not the material inside the control box. (2) Stand for optional return water and water outlet temperature display function. (3)Means equipped with magnetic pump. (4)Means optional air-blowing cleaning function. (5) Optional flow meter and pressure meter. 注: (1)表示非电控箱内材料;(2)表示选配回水和出水温度显示功能;(3)表示选配磁力泵浦;(4)表示选配气吹排空功能;(5)表示选配流量计。																
STM-607W 版本Ver.G		STM-607MW 版本Ver.F		STM-607WA 版本Ver.F		制图		版号 J		标题 STM-607W		图号 STM-607W-CE-400V-J-6		比例		
						设计		核准		 信易電熱機械股份有限公司 Shini Plastics Technologies, Inc.		标准 CE		第 6 张		
						校对						机器电压 3φ400V				
标记		更改前		更改后		更改人		日期 20230114				机器频率 50Hz				
1		2		3		4		5		6		7		8		

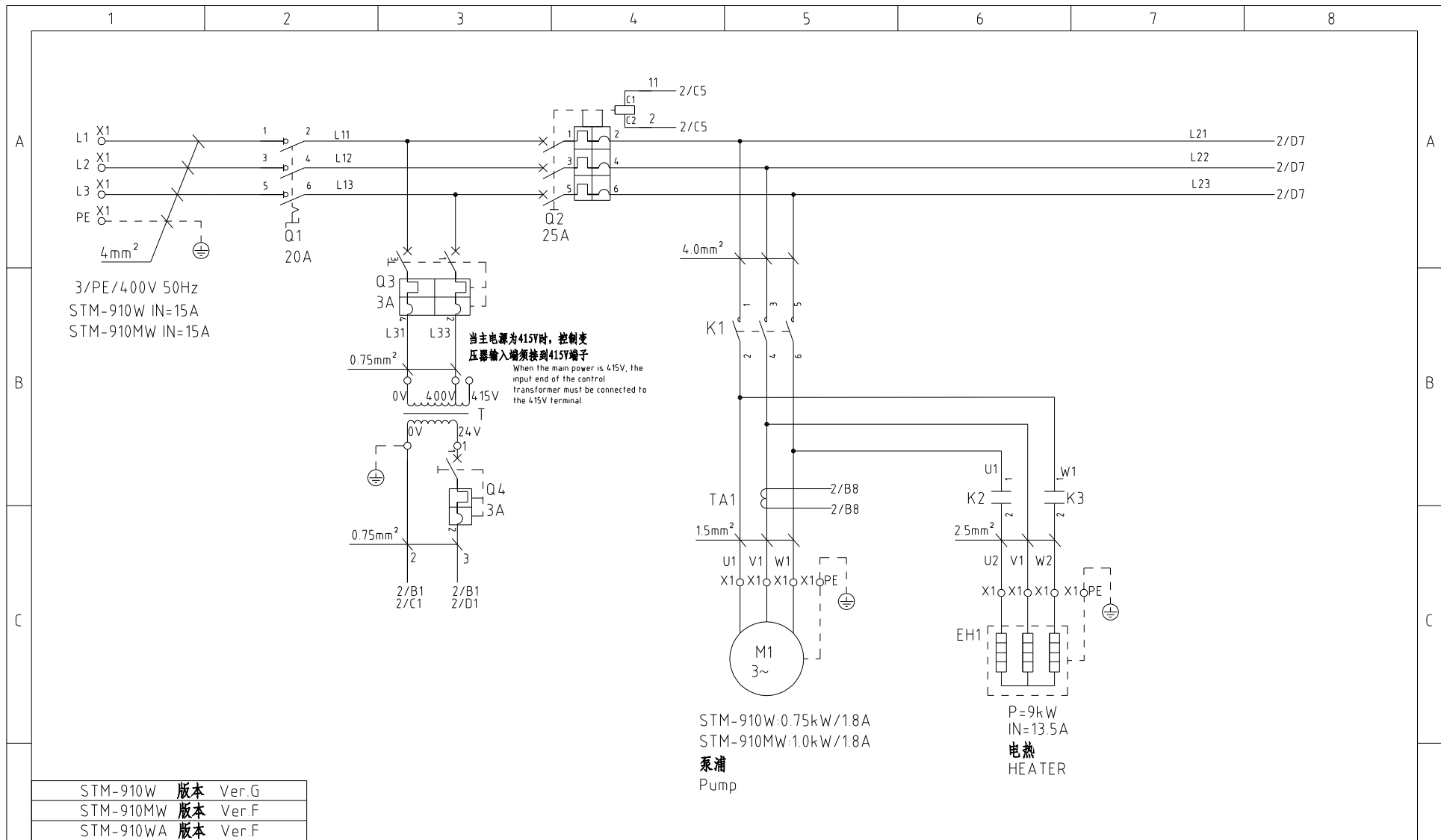

STM-910W	版本	Ver.G
STM-910MW	版本	Ver.F
STM-910WA	版本	Ver.F

					制图	版号	J	标题	STM-910W	图号	STM-910W-CE-400V-J-1	比例	第 1 张	
					设计	核准		主电路				标准	CE	共 6 张
					校对				信易電熱機械股份有限公司 Shini Plastics Technologies, Inc.		机器电压	3φ400V		
标记	更改前	更改后	更改人	日期	审核	日期	20230114				机器频率	50Hz		

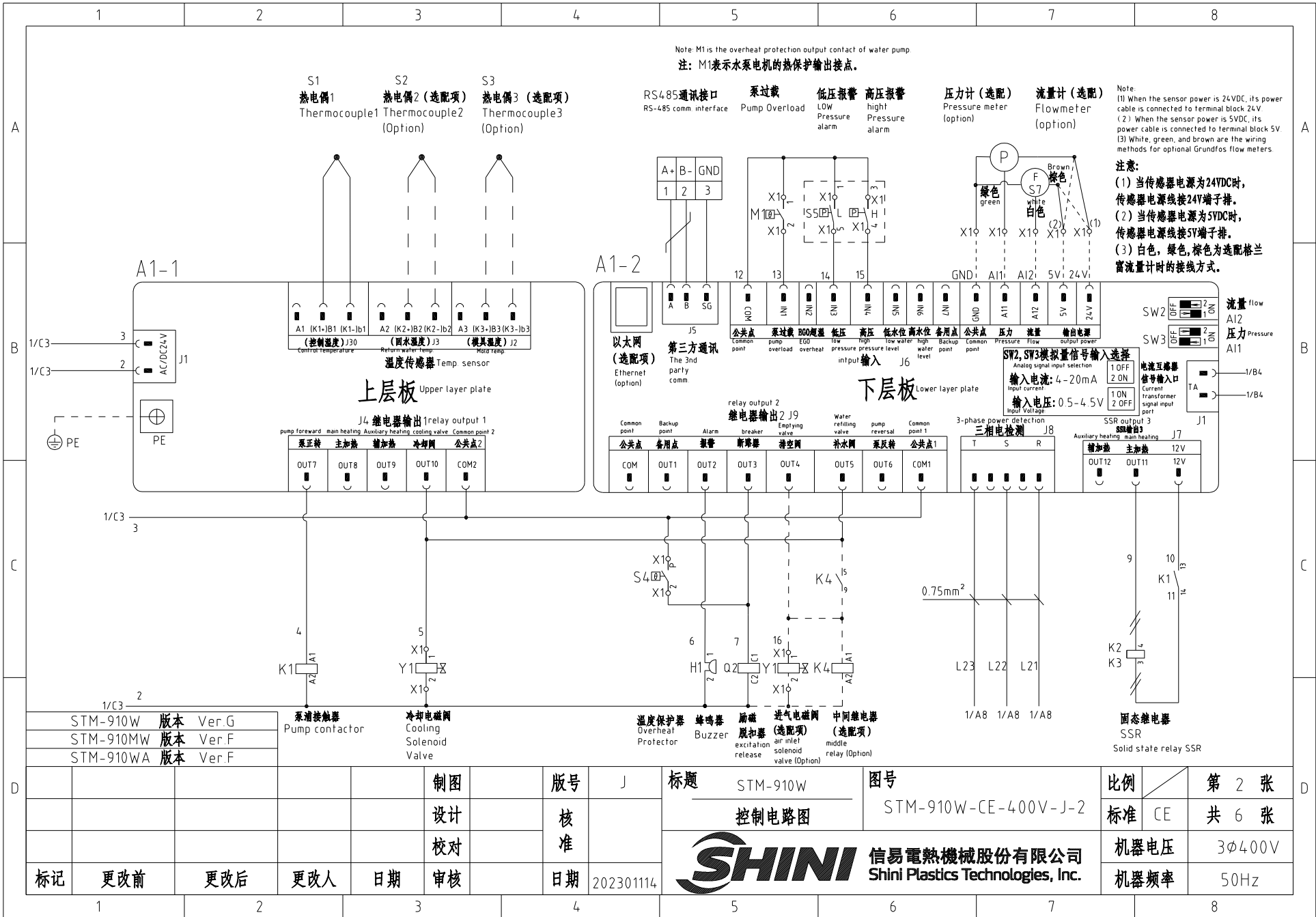

标记	更改前	更改后	更改人	日期	审核	日期	202301114	版号	J	标题	STM-910W 控制电路图	图号	STM-910W-CE-400V-J-2	比例	第 2 张
								核准						标准	CE 共 6 张
														机器电压	3φ400V
														机器频率	50Hz



信易电热机械股份有限公司
Shini Plastics Technologies, Inc.

信易辅机RS-485通讯接线示意图

Shini auxiliary machine RS-485 comm. wiring diagram

信易辅机(从站) Shini auxiliary machine (slave station)

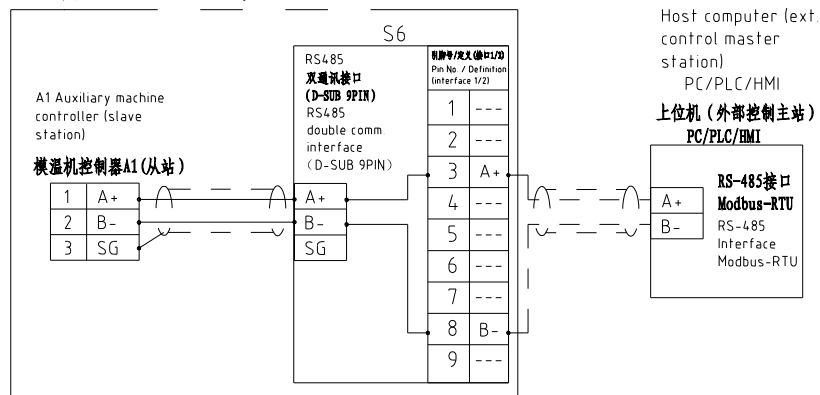

信易RS-485接口定义

Shini RS-485 interface definition

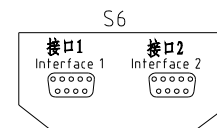

D-sub-9母接口 D-sub-9 pin interface	引脚号 Pin No.	引脚定义 Pin definition
	1	-
	2	-
	3	A+ (RS-485 信号) A+ (RS-485 signal)
	4	-
	5	-
	6	-
	7	-
	8	B- (RS-485 信号) B- (RS-485 signal)
	9	-

注: 1. 通讯接口: RS-485 (两线式)

2. 通讯协议: Modbus-RTU

3. 机器配备D-sub9母接头, 接口1和接口2内部并联, 功能相同, 不分主次;

Note:

1 Comm. interface: RS-485 (two wire)

2 Comm. protocol: Modbus-RTU

3. The machine is equipped with D-sub9 female connector; interface 1 and interface 2 are connected in parallel and have the same function, which is regardless of primary and secondary.

STM-910W	版本	Ver.G
STM-910MW	版本	Ver.F
STM-910WA	版本	Ver.F

				制图	版号	J	标题	STM-910W	图号	比例	第 3 张
				设计	核		通讯接线图	STM-910W-CE-400V-J-3	标准	CE	共 6 张
				校对	准			信易电热机械股份有限公司		机器电压	3φ400V
标记	更改前	更改后	更改人	日期	审核	日期		202301114	Shini Plastics Technologies, Inc.		机器频率

Note:
 (1) When the sensor power is 24VDC, its power cable is connected to terminal block 24V.
 (2) When the sensor power is 5VDC, its power cable is connected to terminal block 5V.
 (3) White, green, and brown are the wiring methods for optional Grundfos flow meters.

注意:
 (1) 当传感器电源为24VDC时, 传感器电源线接24V端子排。
 (2) 当传感器电源为5VDC时, 传感器电源线接5V端子排。
 (3) 白色, 绿色, 棕色为选配格兰流量计时的接线方式。

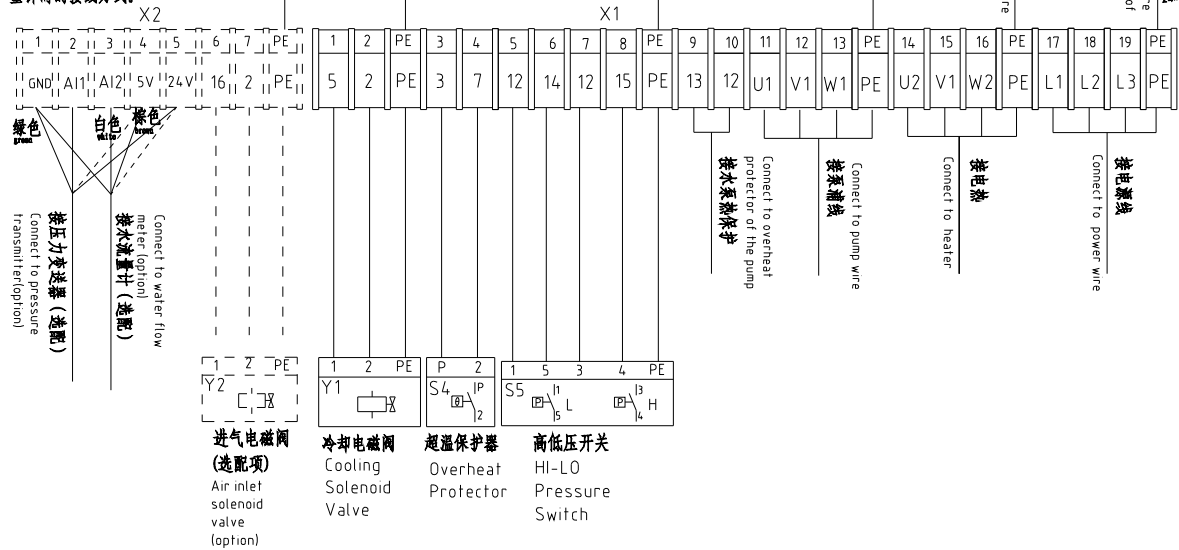
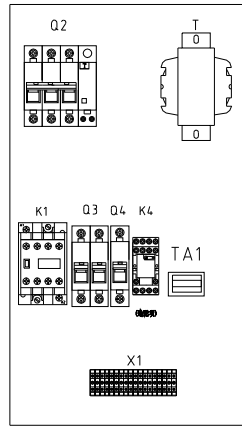
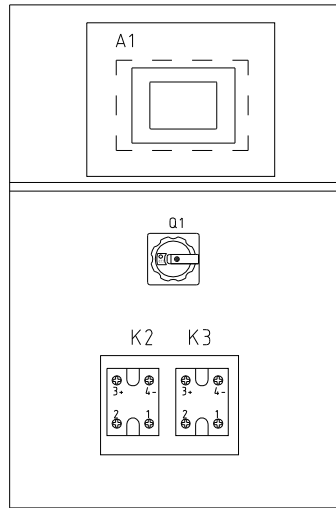

Tech. Req:
 Aluminum cooler grounding wire
技术要求: 铝散热器接地线。

STM-910W	版本	Ver.G
STM-910MW	版本	Ver.F
STM-910WA	版本	Ver.F

					制图	版号	J	标题	STM-910W	图号	STM-910W-CE-400V-J-4	比例	第 4 张
					设计	核		电气元件布置及端子接线图		标准	CE	共 6 张	
					校对	准				机器电压	3φ400V		
标记	更改前	更改后	更改人	日期	审核	日期	202301114			机器频率	50Hz		



信易電熱機械股份有限公司
 Shini Plastics Technologies, Inc.

1		2		3		4		5		6		7		8	
序号/NO	符号/Symbol	名称/Name		制造商/Manufacturer		型号/Type		规格/Specification		单位/unit	数量/Number	物料编号/Material number		备注/Remark	
A	1	Q1	主电源开关/Main power Switch		EATON		TO-2-1/EA/SVB		20A		PCS	1.000	YE10021160000		
	2	Q2	断路器/Circuit Breakers		TECO		BM-63C/3025S		25A		PCS	1.000	YE40302503000		
	3		励磁脱扣器/Excitation release		TECO		MX		24VAC		PCS	1.000	YE40024000000		
	4	Q3	断路器/Circuit Breakers		TECO		BM-63C/2003S 2P		3A		PCS	1.000	YE40200203000		
	5	Q4	断路器/Circuit Breakers		TECO		BM-63C/1003S 1P		3A		PCS	1.000	YE40100203000		
	6	K1	接触器/Contactors		SIEMENS		3RT6016-1AB01		24VAC		PCS	1.000	YE00601602500		
	7	K2 K3	固态继电器/Solid-State Relay		FOTEK		KSR-40DA-H		40A/480VAC/4-32VDC		PCS	2.000	YE03404003200		
B	8	K4	中间继电器/middle relay		HONEYWELL		GR-2C-AC24V		24VAC		PCS	1.000	YE03022400300		(4)
	9	T	互感器/Sensor transformer		JIUXIN		IN=400V/415V OUT=24V		80VA		PCS	1.000	YE70040006500		
	10	S6	通信接口板RS-485 (双Dsub-9pin接口) Communication interface board RS-485 (double Dsub-9pin connector)		YUYUN		----		----		PCS	1.000	YR40048500000		
	11		外壳RS485 (SAL-700G-A-19) 0版 Shell RS485(SAL-700G-A-19)0		BINCHENG		----		----		PCS	1.000	YE84003500600		
	12	A1	线路板/Circuit Board		PUNP		STM-O/-W(24VAC)		SF518501A.03		ST	1.000	YE81245100100		
	13	H1	蜂鸣器/Buzzer		JINGKANG		PK-35A		24VAC/DC		PCS	1.000	YE84003500600		
	14	X1	端子排/Terminal Board		HONEYWELL		SK2.5		2.5mm ²		PCS	13.000	YE60002503200		
C	15		接地端子排/Grounding terminal board		HONEYWELL		SK2.5PE		2.5mm ² PE		PCS	3.000	YE60002503400		
	16		端子排/Terminal Board		HONEYWELL		SK4		4mm ²		PCS	6.000	YE60000403200		
	17		接地端子排/Grounding terminal board		HONEYWELL		GK5PE		5mm ² PE		PCS	2.000	YE60000403500		
	18	X2	端子排/Terminal Board		HONEYWELL		SK2.5		2.5mm ²		PCS	2.000	YE60002503200		(4)
	19		接地端子排/Grounding terminal board		HONEYWELL		SK2.5PE		2.5mm ² PE		PCS	1.000	YE60002503400		(4)
	20		接地端子排/Grounding terminal board		HONEYWELL		SK2.5PE		2.5mm ²		PCS	5.000	YE60002503200		(5)
	21		终端固定件E/CN系列(霍尼韦尔) Terminal fittings E/CN series (honeywell)		HONEYWELL		----		----		PCS	6.000	YE60000003900		
	22		铝散热器 aluminum cooler		SHINI		----		----		BA	1.000	YW90120700000		
	23	TA1	单电流互感器 Single current transformer		PUNP		IGW122C		1		PCS	1.000	YE04012204400		
	24	S1	热电偶/Thermocouple		SHINI		----		K		PCS	1	----		(1)
25	S2 S3	热电偶/Thermocouple		SHINI		----		K		PCS	2	----		(1)(2)	
STM-910W 版本Ver.G		STM-910MW 版本Ver.F		STM-910WA 版本Ver.F		注: (1)表示带电控制附件;(2)表示带回流水和出水温度显示功能;(3)表示带磁力泵功能;(4)表示带回气吹扫功能;(5)表示带磁流量计。 Notes: (1)Means it's not the material inside the control box. (2) Stand for optional return water and water outlet temperature display function. (3)Means equipped with magnetic pump. (4)Means optional air-blowing cleaning function. (5) Optional flow meter and pressure meter.									
				制图		版本号		J		标题		STM-910W		图号	
				设计		核				电气元件明细表一		STM-910W-CE-400V-J-5		比例	
				校对		准				 信易电热机械股份有限公司 Shini Plastics Technologies, Inc.		标准		CE	
标记		更改前		更改后		更改人		日期				202301114		机器电压	
				审核		日期						机器频率		50Hz	
1		2		3		4		5		6		7		8	

A

B

C

D

1		2		3		4		5		6		7		8			
序号/NO	符号/Symbol	名称/Name			制造商/Manufacturer		型号/Type		规格/Specification		单位/unit	数量/Number	物料编号/Material number		备注/Remark		
26	S4	超温保护器/Overheat Protector			----		----		----			1	----		(1)		
27	S5	高低压开关/HI-LO pressure switch			----		----		----			1	----		(1)		
A	28	S7	流量计/Flowmeter			CRUNDFOS		VFS QT 2-40		2-40L/min			1	----		(1)(5)	
	29	M1	马达/Motor			SHINI		TP-75		400V 50Hz 0.75kW			1	----		(1)	
	30	M1	马达/Motor			SHINI		MP-100		400V 50Hz 1.0kW			1	----		(1)(3)	
	31	EH	电热/Heater			SHINI		----		400V 50Hz 9kW			1	----		(1)	
	32	Y1	电磁阀/Solenoid Valve			----		----		24VAC			1	----		(1)	
	33	Y2	电磁阀/Solenoid Valve			----		----		24VAC			1	----		(1)(4)	
<p>Notes: (1)Means it 's not the material inside the control box. (2) Stand for optional return water and water outlet temperature display function. (3)Means equipped with magnetic pump. (4)Means optional air-blowing cleaning function. (5) Optional flow meter and pressure meter.</p>																	
STM-910W 版本Ver.G		STM-910MW 版本Ver.F		STM-910WA 版本Ver.F		注: (1)表示非电控箱内材料;(2)表示选配回水和出水温度显示功能;(3)表示选配磁力泵浦;(4)表示选配气吹排空功能;(5)表示选配流量计。											
				制图		版号		J		标题		图号		比例		第 6 张	
				设计		核				STM-910W		STM-910W-CE-400V-J-6		标准		CE	
				校对		准				 信易電熱機械股份有限公司 Shini Plastics Technologies, Inc.		机器电压		3φ400V			
标记		更改前		更改后		更改人		日期				日期		202301114		机器频率	
1		2		3		4		5		6		7		8			

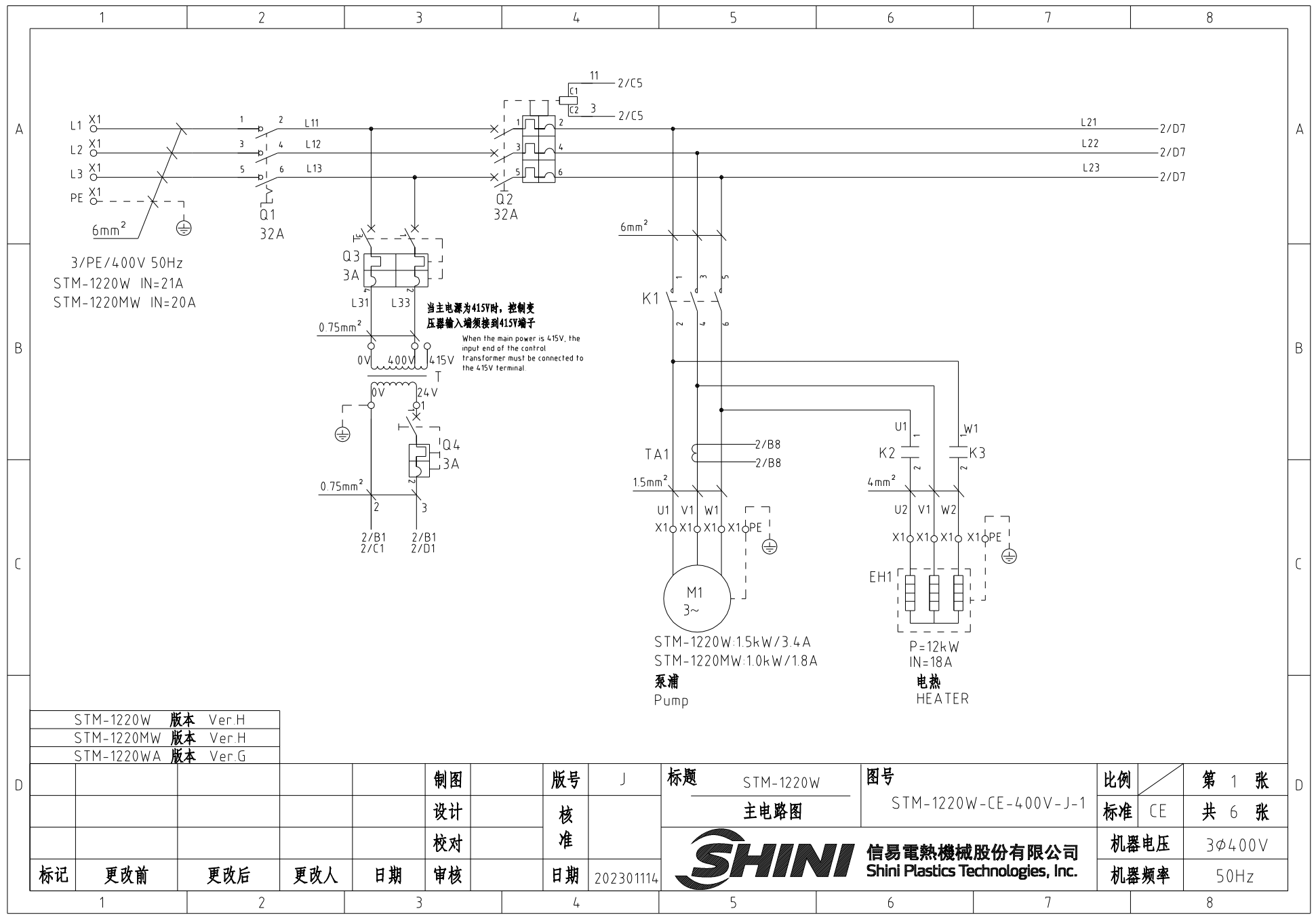

STM-1220W	版本	Ver.H
STM-1220MW	版本	Ver.H
STM-1220WA	版本	Ver.G

D	制图	版号	J	标题	STM-1220W	图号	STM-1220W-CE-400V-J-1	比例	第 1 张
	设计	核准		主电路			标准	CE	共 6 张
	校对	日期	20230114	信易电热机械股份有限公司 Shini Plastics Technologies, Inc.	机器电压	3φ400V			
	标记	更改前	更改后		更改人	日期	审核	机器频率	50Hz

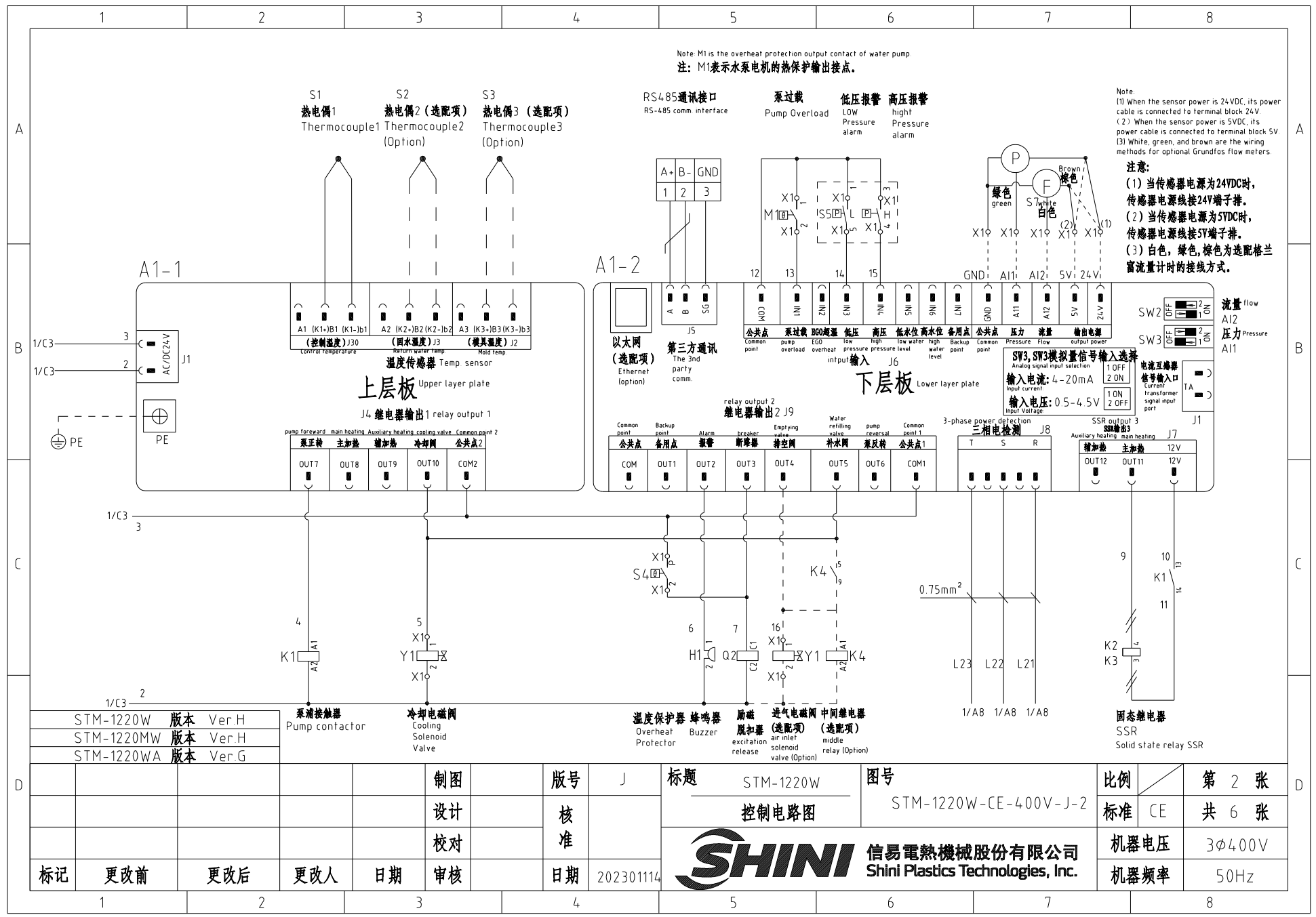

Note: M1 is the overheat protection output contact of water pump
注: M1表示水泵电机的热保护输出接点。

Note:
(1) When the sensor power is 24VDC, its power cable is connected to terminal block 24V
(2) When the sensor power is 5VDC, its power cable is connected to terminal block 5V
(3) White, green, and brown are the wiring methods for optional Grundfos flow meters.

注意:
(1) 当传感器电源为24VDC时, 传感器电源线接24V端子排。
(2) 当传感器电源为5VDC时, 传感器电源线接5V端子排。
(3) 白色, 绿色, 棕色为选配格兰流量计时的接线方式。

STM-1220W	版本	Ver.H
STM-1220Mw	版本	Ver.H
STM-1220WA	版本	Ver.G

标记	更改前	更改后	更改人	日期	审核	日期	202301114
					制图	版号	J
					设计	核准	
					校对		

标题	STM-1220W	图号	STM-1220W-CE-400V-J-2
控制电路图			
信易电热机械股份有限公司		Shini Plastics Technologies, Inc.	

比例	第 2 张
标准	共 6 张
机器电压	3φ400V
机器频率	50Hz

信易辅机RS-485通讯接线示意图

Shini auxiliary machine RS-485 comm. wiring diagram

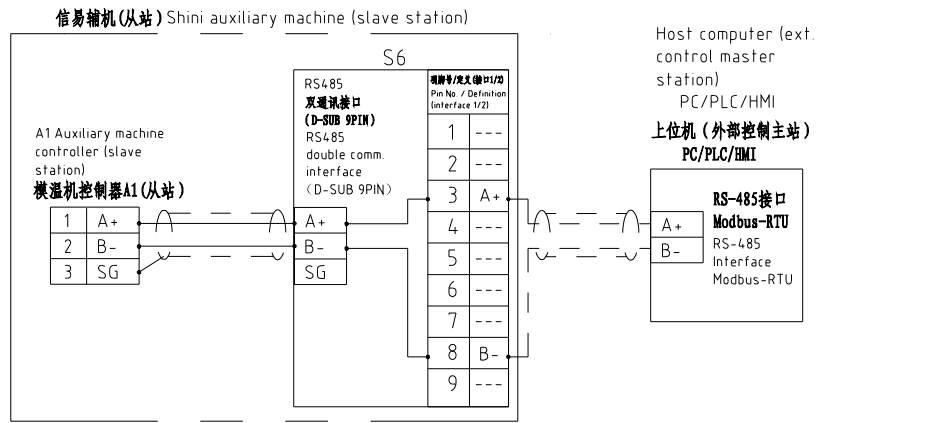

信易RS-485接口定义

Shini RS-485 interface definition

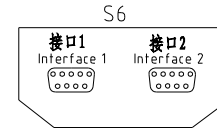

D-sub-9母接口 D-sub-9 pin interface	引脚号 Pin No.	引脚定义 Pin definition
	1	-
	2	-
	3	A+ (RS-485 信号) A+ (RS-485 signal)
	4	-
	5	-
	6	-
	7	-
	8	B- (RS-485 信号) B- (RS-485 signal)
	9	-

- 注: 1. 通讯接口: RS-485 (两线式)
 2. 通讯协议: Modbus-RTU
 3. 机器配备D-sub9母接头, 接口1和接口2内部并联, 功能相同, 不分主次;

Note:
 1 Comm. interface: RS-485 (two wire)
 2 Comm. protocol: Modbus-RTU
 3. The machine is equipped with D-sub9 female connector; interface 1 and interface 2 are connected in parallel and have the same function, which is regardless of primary and secondary.

STM-1220W	版本	Ver.H
STM-1220Mw	版本	Ver.H
STM-1220WA	版本	Ver.G

						制图	版号	J	标题	STM-1220W	图号	比例	第 3 张
						设计	核		通讯接线图	STM-1220W-CE-400V-J-3		标准	共 6 张
						校对	准		信易電熱機械股份有限公司 Shini Plastics Technologies, Inc.	机器电压	3φ400V		
标记	更改前	更改后	更改人	日期	审核	日期	20230114	机器频率		50Hz			

Note:
 (1) When the sensor power is 24VDC, its power cable is connected to terminal block 24V.
 (2) When the sensor power is 5VDC, its power cable is connected to terminal block 5V.
 (3) White, green, and brown are the wiring methods for optional Grundfos flow meters.

注意:

- (1) 当传感器电源为24VDC时, 传感器电源线接24V端子排。
- (2) 当传感器电源为5VDC时, 传感器电源线接5V端子排。
- (3) 白色, 绿色, 棕色为选配格兰流量计时的接线方式。

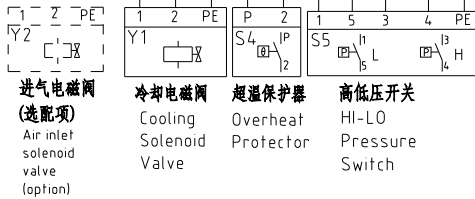
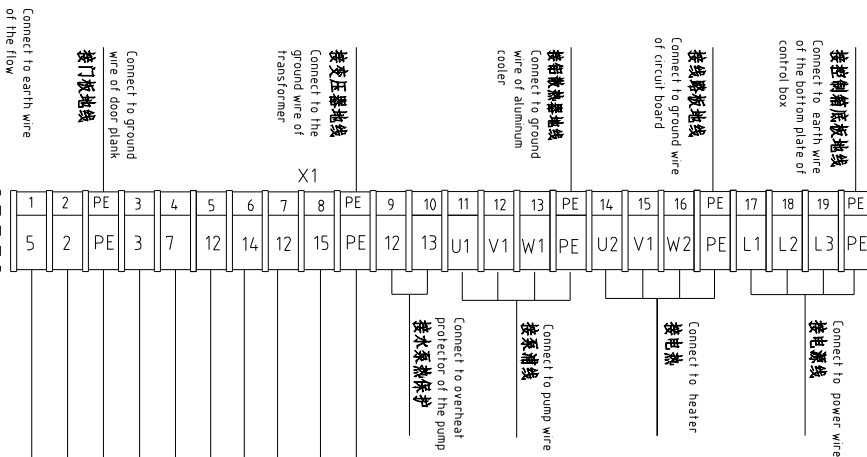
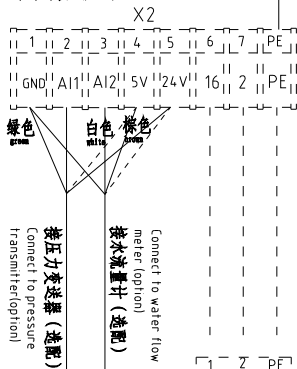
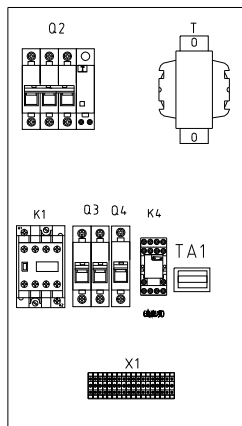
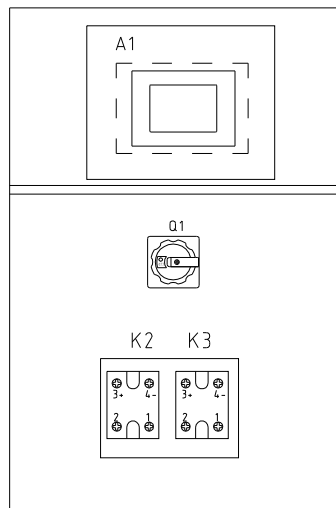

STM-1220W	版本	Ver.H
STM-1220Mw	版本	Ver.H
STM-1220WA	版本	Ver.G
标记	更改前	更改后

Tech Req:
 Aluminum cooler grounding wire
技术要求: 铝散热器接地线。

制图	版号	J
设计	核准	
校对	核准	
审核	日期	20230114

标题	STM-1220W	图号	STM-1220W-CE-400V-J-4
电气元件布置及端子接线图		比例	第 4 张
		标准	CE



信易电热机械股份有限公司
 Shini Plastics Technologies, Inc.

比例	第 4 张
标准	共 6 张
机器电压	3φ400V
机器频率	50Hz

1		2		3		4		5		6		7		8	
序号/NO	符号/Symbol	名称/Name		制造商/Manufacturer		型号/Type		规格/Specification		单位/unit	数量/Number	物料编号/Material number		备注/Remark	
1	Q1	主电源开关/Main power Switch		EATON		P1-32/EA/SVB		32A		PCS	1.000	YE10323200000			
2	Q2	断路器/Circuit Breakers		TECO		BM-63C/3032S		32A		PCS	1.000	YE40303203000			
3		励磁脱扣器/Excitation release		TECO		MX		24VAC		PCS	1.000	YE40024000000			
4	Q3	断路器/Circuit Breakers		TECO		BM-63C/2003S 2P		3A		PCS	1.000	YE40200203000			
5	Q4	断路器/Circuit Breakers		TECO		BM-63C/1003S 1P		3A		PCS	1.000	YE40100203000			
6	K1	接触器/Contactors		SIEMENS		3RT6023-1AC20		24VAC		PCS	1.000	YE00602301100			
7	K2 K3	固态继电器/Solid-State Relay		FOTEK		KSR-40DA-H		40A/480VAC/4-32VDC		PCS	2.000	YE03404003200			
8	K4	中间继电器/Middle relay		HONEYWELL		GR-2C-AC24V		24VAC		PCS	1.000	YE03022400300		(4)	
9	T	互感变压器/Sensor transformer		JIUXIN		IN=400V/415V OUT=24V		80VA		PCS	1.000	YE70040006500			
10	S6	通信接口板RS-485 (双Dsub-9pin接头) Communication interface board RS-485 (double Dsub-9pin connector)		YUYUN		----		----		PCS	1.000	YE90048501200			
11		外壳RS485 (SAL-700G-A-19) 0版 Shell RS485(SAL-700G-A-19)0		BINCHENG		----		----		PCS	1.000	YR40048500000			
12	A1	线路板/Circuit Board		PUNP		STM-O/-W(24VAC)		SF518501A.03		ST	1.000	YE81245100100			
13	H1	蜂鸣器/Buzzer		JINGKANG		PK-35A		24VAC/DC		PCS	1.000	YE84003500600			
14	X1	端子排/Terminal Board		HONEYWELL		SK2.5		2.5mm ²		PCS	13.000	YE60002503200			
15		接地端子排/Grounding terminal board		HONEYWELL		SK2.5PE		2.5mm ² PE		PCS	3.000	YE60002503400			
16		端子排/Terminal Board		HONEYWELL		SK4		4mm ²		PCS	3.000	YE60000403200			
17		接地端子排/Grounding terminal board		HONEYWELL		GK5PE		5mm ² PE		PCS	1.000	YE60000403500			
18		端子排/Terminal Board		HONEYWELL		GK6		6mm ²		PCS	3.000	YE60000603200			
19		接地端子排/Grounding terminal board		HONEYWELL		GK6PE		6mm ² PE		PCS	1.000	YE60000603500			
20	X2	端子排/Terminal Board		HONEYWELL		SK2.5		2.5mm ²		PCS	2.000	YE60002503200		(4)	
21		接地端子排/Grounding terminal board		HONEYWELL		SK2.5PE		2.5mm ² PE		PCS	1.000	YE60002503400		(4)	
22		接地端子排/Grounding terminal board		HONEYWELL		SK2.5PE		2.5mm ²		PCS	5.000	YE60002503200		(5)	
23		终端固定件E/GK系列(索尼韦尔) Terminal fittings E/GK series (honeywell)		HONEYWELL		----		----		PCS	6.000	YE60000003900			
24		铝散热器 aluminum cooler		SHINI		----		----		BA	1.000	YW90120700000			
25	TA1	单电流互感器 Single current transformer		PUNP		LGW122C		1		PCS	1.000	YE04012204400			
STM-1220W 版本Ver.H		STM-1220MW 版本Ver.H		STM-1220WA 版本Ver.G		注: (1)表示带电插销材料; (2)表示电箱款式和颜色显示功能; (3)表示电箱颜色灰度; (4)表示电箱气吹清洗功能; (5)表示电箱流量、压力计。 Notes: (1)Means it 's not the material inside the control box. (2) Stand for optional return water and water outlet temperature display function. (3)Means equipped with magnetic pump. (4)Means optional air-blowing cleaning function. (5) Optional flow meter and pressure meter.									
				制图		版本号		J		标题		STM-1220W		图号	
				设计		核				电气元件明细表一		STM-1220W-CE-400V-J-5		比例	
				校对		准				 信易電熱機械股份有限公司 Shini Plastics Technologies, Inc.		机器电压		3φ400V	
标记		更改前		更改后		更改人		日期				202301114		机器频率	
1		2		3		4		5		6		7		8	

1		2		3		4		5		6		7		8							
序号/NO	符号/Symbol	名称/Name		制造商/Manufacturer		型号/Type		规格/Specification		单位/unit	数量/Number	物料编号/Material number		备注/Remark							
26	S1	热电偶/Thermocouple		SHINI		----		K		PCS	1	----		(1)							
27	S2 S3	热电偶/Thermocouple		SHINI		----		K		PCS	2	----		(1)(2)							
A	28	S4	超温保护器/Overheat Protector		----		----		----			1	----		(1)						
	29	S5	高低压开关/Hi-Lo pressure switch		----		----		----			1	----		(1)						
	30	S7	流量计/Flowmeter		CRUNDFOS		VFS QT 2-40		2-40L/min			1	----		(1)(5)						
	31	M1	马达/Motor		SHINI		TP-150		400V 50Hz 1.5kW			1	----		(1)						
	32	M1	马达/Motor		SHINI		MP-100		400V 50Hz 1.0kW			1	----		(1)(3)						
	33	EH	电热/Heater		SHINI		----		400V 50Hz 12kW			1	----		(1)						
	34	Y1	电磁阀/Solenoid Valve		----		----		24VAC			1	----		(1)						
	35	Y2	电磁阀/Solenoid Valve		----		----		24VAC			1	----		(1)(4)						
B																B					
C																C					
D																D					
<p>Notes: (1)Means it 's not the material inside the control box. (2) Stand for optional return water and water outlet temperature display function. (3)Means equipped with magnetic pump. (4)Means optional air-blowing cleaning function. (5) Optional flow meter and pressure meter.</p> <p>注: (1)表示非电控箱内材料; (2)表示选配出水 and 回水温度显示功能; (3)表示选配磁力泵; (4)表示选配气吹排空功能; (5)表示选配流量, 压力计。</p>																					
STM-1220W 版本Ver.H		STM-1220MW 版本Ver.H		STM-1220WA 版本Ver.G		制图		版号		J		标题		STM-1220W		图号		比例		第 6 张	
						设计		核				电气元件明细表二		STM-1220W-CE-400V-J-6		标准		CE		共 6 张	
						校对		准				 信易電熱機械股份有限公司 Shini Plastics Technologies, Inc.		机器电压		3φ400V					
标记		更改前		更改后		更改人		日期		202301114				机器频率		50Hz					
1		2		3		4		5		6		7		8							

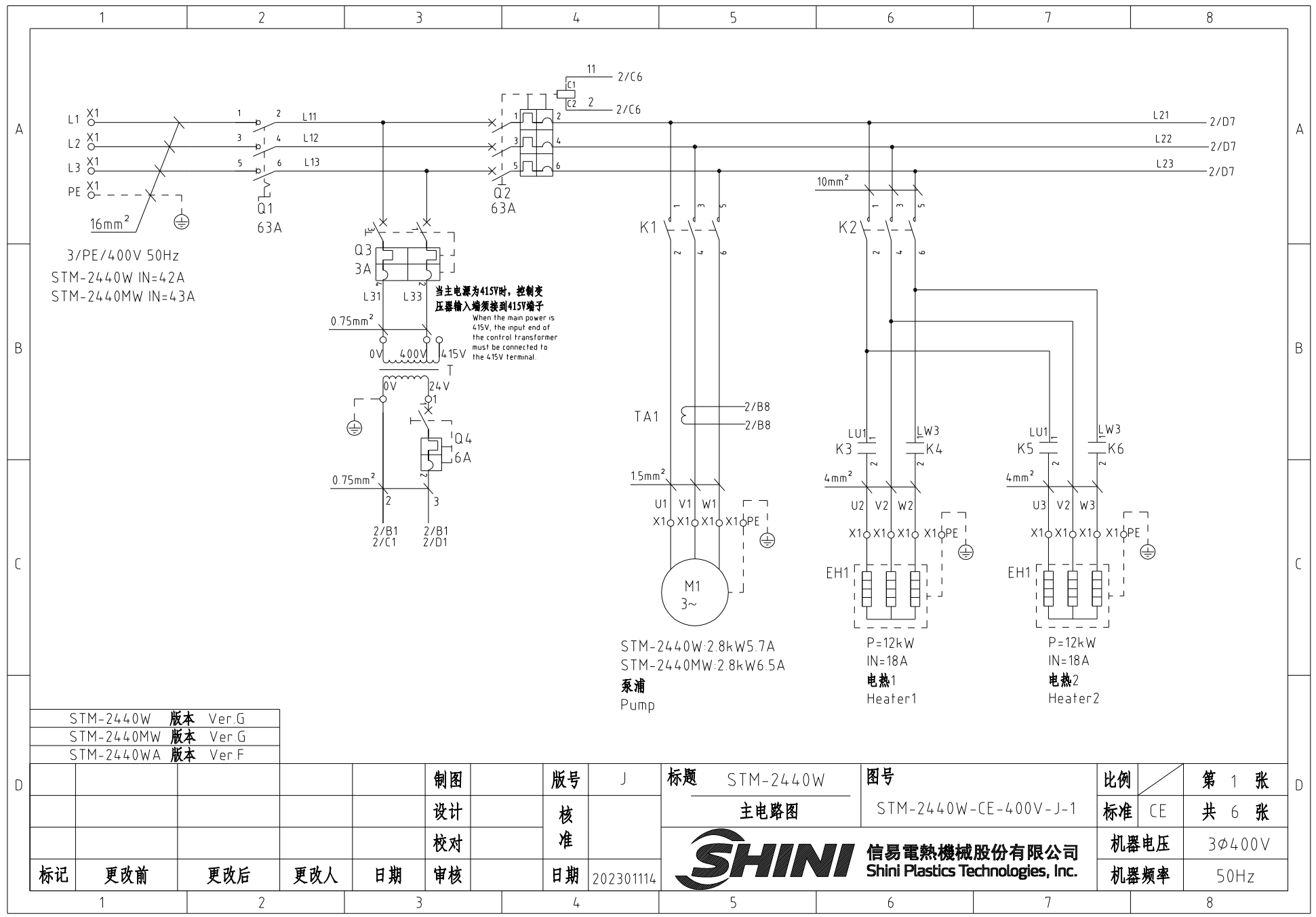

STM-2440W	版本	Ver.G
STM-2440MW	版本	Ver.G
STM-2440WA	版本	Ver.F

D	制图	版号	J	标题	STM-2440W	图号	STM-2440W-CE-400V-J-1	比例	第 1 张
	设计	核准		主电路图			CE	共 6 张	
	校对	日期	202301114	信易电热机械股份有限公司 Shini Plastics Technologies, Inc.		机器电压	3φ400V		
	标记	更改前	更改后			更改人	日期	机器频率	50Hz

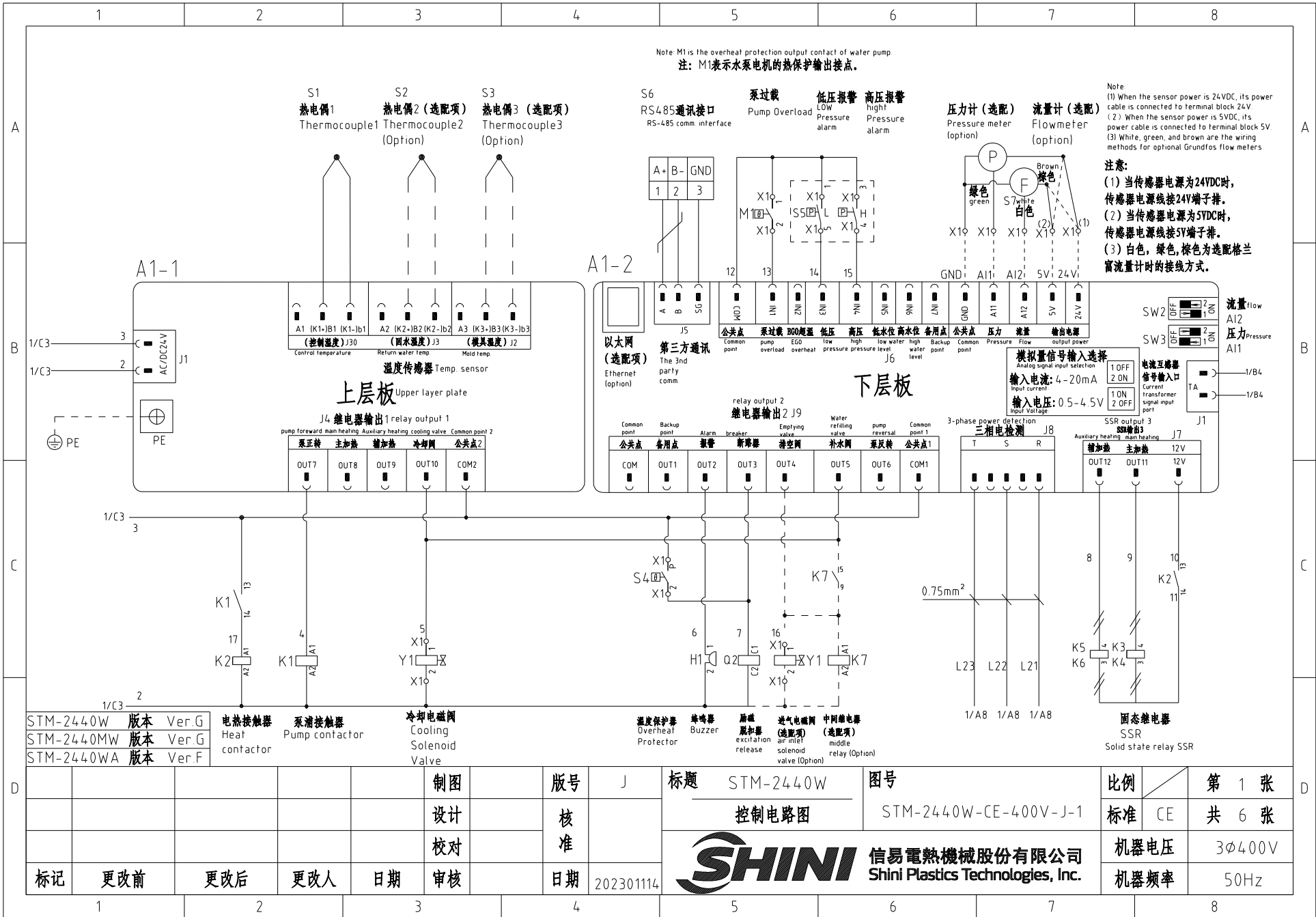

Note: M1 is the overheat protection output contact of water pump
注: M1表示水泵电机的热保护输出接点。

Note:
(1) When the sensor power is 24VDC, its power cable is connected to terminal block 24V.
(2) When the sensor power is 5VDC, its power cable is connected to terminal block 5V.
(3) White, green, and brown are the wiring methods for optional Grundfos flow meters.

注意:
(1) 当传感器电源为24VDC时, 传感器电源线接24V端子排。
(2) 当传感器电源为5VDC时, 传感器电源线接5V端子排。
(3) 白色, 绿色, 棕色为选配格兰流量计时的接线方式。

STM-2440W	版本 Ver.G
STM-2440MW	版本 Ver.G
STM-2440WA	版本 Ver.F

电热器接触器	泵浦接触器	冷却电磁阀
Heat contactor	Pump contactor	Cooling Solenoid Valve

温度保护器	蜂鸣器	风扇启动器	进气电磁阀 (选配项)	中间继电器 (选配项)
Overheat Protector	Buzzer	Fan excitation solenoid	air inlet valve (Option)	middle relay (Option)

三相检测	固态继电器
3-phase power detection	SSR Solid state relay SSR

制图	版号	J	标题	STM-2440W	图号	STM-2440W-CE-400V-J-1	比例	第 1 张
设计	核准		控制电路图				标准	共 6 张
更改前	更改后	更改人	日期	20230114	信易电热机械股份有限公司 Shini Plastics Technologies, Inc.		机器电压	3φ400V
标记	更改后	日期	20230114	机器频率			50Hz	

信易辅机RS-485通讯接线示意图

Shini auxiliary machine RS-485 comm. wiring diagram

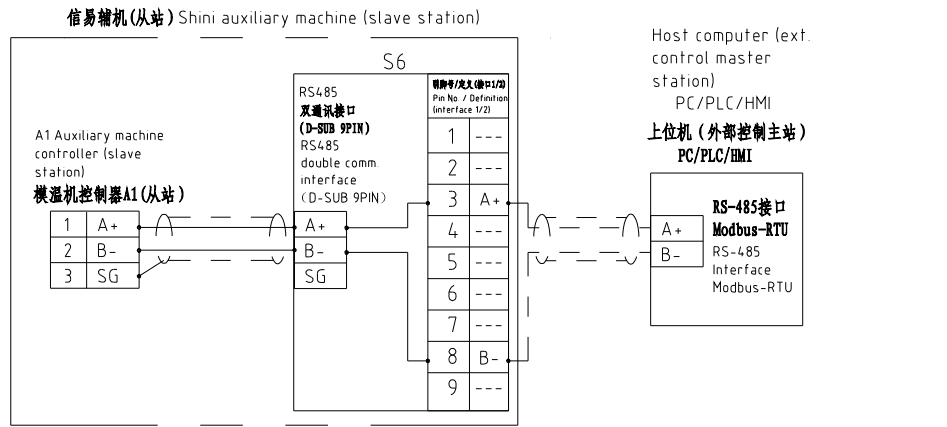

信易RS-485接口定义 Shini RS-485 interface definition

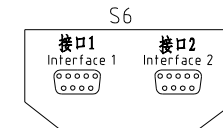

D-sub-9母接口 D-sub-9 pin interface	引脚号 Pin No.	引脚定义 Pin definition
	1	---
	2	---
	3	A+ (RS-485 信号) A+ (RS-485 signal)
	4	---
	5	---
	6	---
	7	---
	8	B- (RS-485 信号) B- (RS-485 signal)
	9	---

- 注: 1. 通讯接口: RS-485 (两线式)
2. 通讯协议: Modbus-RTU
3. 机器配备D-sub9母接头, 接口1和接口2内部并联, 功能相同, 不分主次;

Note
1 Comm. interface: RS-485 (two wire)
2 Comm. protocol: Modbus-RTU
3 The machine is equipped with D-sub9 female connector; interface 1 and interface 2 are connected in parallel and have the same function, which is regardless of primary and secondary.

STM-2440W	版本	Ver.G
STM-2440Mw	版本	Ver.G
STM-2440WA	版本	Ver.F

					制图		版号	J	标题	STM-2440W	图号		比例	第 1 张
					设计		核		通讯接线图		STM-2440W-CE-400V-J-1		标准	共 6 张
					校对		准						机器电压	3φ4.00V
标记	更改前	更改后	更改人	日期	审核		日期	202301114	SHINI	信易电热机械股份有限公司 Shini Plastics Technologies, Inc.			机器频率	50Hz
1	2	3	4	5	6	7	8							

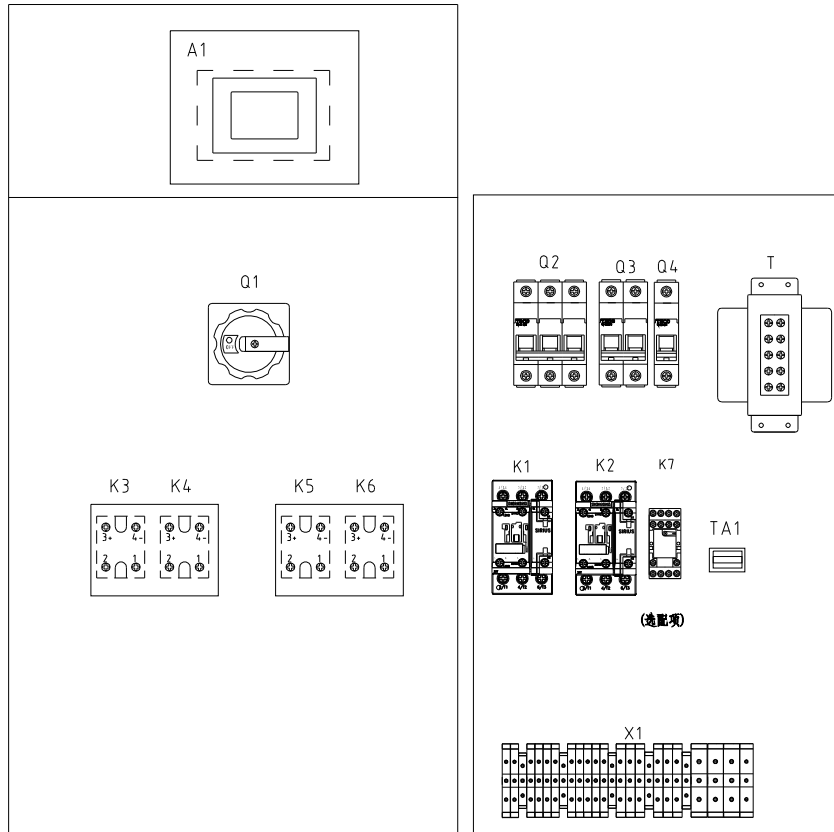

电控外箱
Control box outer case

电控底板
Base plate of control box

技术要求: 铝散热器接地线. Tech. Req: Aluminum cooler grounding wire

STM-2440W	版本	Ver.G
STM-2440Mw	版本	Ver.G
STM-2440WA	版本	Ver.F

D					制图		版号	J	标题	STM-2440W	图号	STM-2440W-CE-400V-J-1	比例	第 4 张
					设计		核		电气元件布置图			标准	CE	共 6 张
					校对		准		 信易電熱機械股份有限公司 Shini Plastics Technologies, Inc.	机器电压	3φ400V			
	标记	更改前	更改后	更改人	日期	审核	日期	20230114		机器频率	50Hz			

1

2

3

4

5

6

7

8

Note:
 (1) When the sensor power is 24VDC, its power cable is connected to terminal block 24V.
 (2) When the sensor power is 5VDC, its power cable is connected to terminal block 5V.

注意:
 (1) 当传感器电源为24VDC时, 传感器电源线接24V端子排。
 (2) 当传感器电源为5VDC时, 传感器电源线接5V端子排。

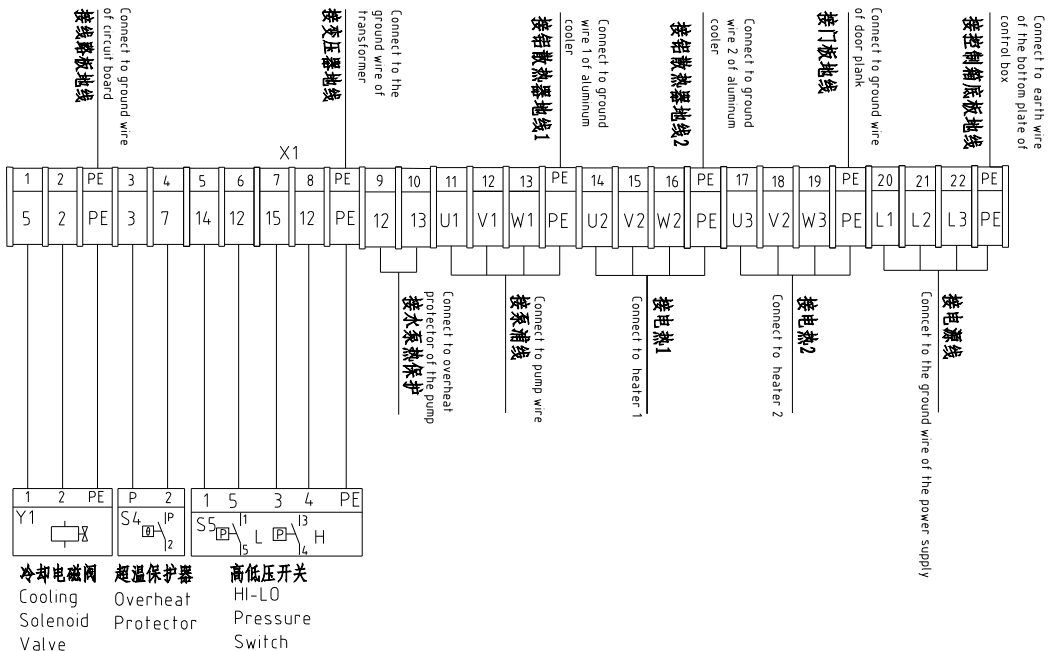
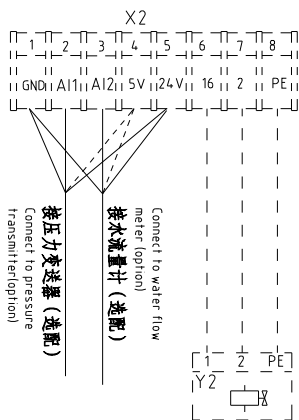

STM-2440W	版本	Ver.G
STM-2440Mw	版本	Ver.G
STM-2440WA	版本	Ver.F

技术要求: 铝散热器接地线. Tech. Req: Aluminum cooler grounding wire

D	制图	版号	J	标题	STM-2440W	图号	STM-2440W-CE-400V-J-1	比例	第 4 张
	设计	核准		端子接线图			标准	CE	共 6 张
	校对	审核	日期	202301114	信易电热机械股份有限公司 Shini Plastics Technologies, Inc.	机器电压	3φ400V		
	标记	更改前	更改后	更改人		日期	机器频率	50Hz	

1		2		3		4		5		6		7		8					
序号/NO	符号/Symbol	名称/Name		制造商/Manufacturer		型号/Type		规格/Specification		单位/unit	数量/Number	物料编号/Material number		备注/Remark					
A	1	Q1	主电源开关/Main power Switch		EATON		P3-63/EA/SVB		63A		PCS	1.000	YE10636300000						
	2	Q2	断路器/Circuit Breakers		TECO		BM-63C/3063S		63A		PCS	1.000	YE40306303000						
	3		励磁脱扣器/Excitation release		TECO		MX		24VAC		PCS	1.000	YE40024000000						
	4	Q3	断路器/Circuit Breakers		TECO		BM-63C/2003S 2P		3A		PCS	1.000	YE40200203000						
	5	Q4	断路器/Circuit Breakers		TECO		BM-63C/1006S 6A 1P		6A		PCS	1.000	YE40100600100						
	6	K1	接触器/Contactors		SIEMENS		3RT6016-1AB01-24VAC		24VAC		PCS	1.000	YE00601602500						
	7	K2	接触器/Contactors		SIEMENS		3RT6027-1AC20		24VAC		PCS	1.000	YE00602702600						
B	8	K3K4K5K6	固态继电器/Solid-State Relay		FOTEK		KSR-40DA-H		40A/480VAC/4-32VDC		PCS	4.000	YE03404003200						
	9	K5	中间继电器/middle relay		HONEYWELL		GR-2C-AC24V		24VAC		PCS	1.000	YE03022400300		(4)				
	10	T	互感变压器/Sensor transformer		JIUXIN		IN=400V/4.15V OUT=24V		120VA		PCS	1.000	YE70040006600						
	11	S6	通信接口板RS-485 (双Dsub-9pin接头) Communication interface board RS-485 (double Dsub-9pin connector)		YUYUN		----		----		PCS	1.000	YE90048501200						
	12		外壳RS485 (SAL-700G-A-19) 0版 Shell RS485(SAL-700G-A-19)0		BINCHENG		----		----		PCS	1.000	YR40048500000						
	13	A1	线路板/Circuit Board		PUNP		STM-0/-W(24VAC)		SF518501A.03		ST	1.000	YE81245100100						
	14	H1	蜂鸣器/Buzzer		JINGKANG		PK-35A		24VAC/DC		PCS	1.000	YE84003500600						
C	15	X1	端子排/Terminal Board		HONEYWELL		SK2.5		2.5mm ²		PCS	13.000	YE60002503200						
	16		接地端子排/Grounding terminal board		HONEYWELL		SK2.5PE		2.5mm ² PE		PCS	3.000	YE60002503400						
	17		端子排/Terminal Board		HONEYWELL		SK4		4mm ²		PCS	6.000	YE60000403200						
	18		接地端子排/Grounding terminal board		HONEYWELL		GK5PE		5mm ² PE		PCS	2.000	YE60000403500						
	19		端子排/Terminal Board		HONEYWELL		GK16		16mm ²		PCS	3.000	YE60001603200						
	20		接地端子排/Grounding terminal board		HONEYWELL		GK16PE		16mm ² PE		PCS	1.000	YE60001603500						
	21	X2	端子排/Terminal Board		HONEYWELL		SK2.5		2.5mm ²		PCS	2.000	YE60002503200		(4)				
	22		接地端子排/Grounding terminal board		HONEYWELL		SK2.5PE		2.5mm ² PE		PCS	1.000	YE60002503400		(4)				
	23		接地端子排/Grounding terminal board		HONEYWELL		SK2.5PE		2.5mm ²		PCS	5.000	YE60002503400		(5)				
	24		终端固定件B/CK系列(霍尼韦尔) Terminal fittings B/CK series(honeywell)		HONEYWELL		----		----		PCS	6.000	YE60000003900						
	25		铝散热器 aluminum cooler		SHINI		----		----		BA	2.000	YW90120700000						
STM-2440W 版本Ver.G		STM-2440MW 版本Ver.G		STM-2440WA 版本Ver.F		注: (1)表示带电接线材料; (2)表示内部出水阀及温度显示功能; (3)表示内部磁力泵; (4)表示内部气吹清洁功能; (5)表示内部流量、压力计。 Notes: (1)Means it's not the material inside the control box. (2) Stand for optional return water and water outlet Temperature display function. (3)Means equipped with magnetic pump. (4)Means optional air-blowing cleaning function. (5) Optional flow meter and pressure meter.													
D				制图		版本号		J		标题		STM-2440W		图号		比例		第 1 张	
				设计		核				电气元件明细表一		STM-2440W-CE-400V-J-1		标准		CE		共 6 张	
				校对		准				 信易电热机械股份有限公司 Shini Plastics Technologies, Inc.		机器电压		3φ400V					
标记		更改前		更改后		更改人		日期				审核		机器频率		50Hz			
1		2		3		4		5		6		7		8					

1		2		3		4		5		6		7		8	
序号/NO	符号/Symbol	名称/Name		制造商/Manufacturer		型号/Type		规格/Specification		单位/unit	数量/Number	物料编号/Material number		备注/Remark	
26	TA1	单电流互感器 Single current transformer		PUNP		I.GW122C		1		PCS	1.000	YE04012204400			
27	S1	热电偶/Thermocouple		SHINI		----		----		PCS	1	----		(1)	
28	S2 S3	热电偶/Thermocouple		SHINI		----		----		PCS	2	----		(1)(2)	
29	S4	超温保护器/Overheat Protector		----		----		----		PCS	1	----		(1)	
30	S5	高低压开关/Hi-Lo pressure switch		----		----		----		PCS	1	----		(1)	
31	Y1	电磁阀/Solenoid Valve		----		----		24 VAC		PCS	1	----		(1)	
32	Y2	电磁阀/Solenoid Valve		----		----		24 VAC		PCS	1	----		(1)(4)	
33	M1	马达/Motor		SHINI		TP-280		400V 50Hz 2.8kW		PCS	1	----		(1)	
34	M1	马达/Motor		SHINI		MP-280		400V 50Hz 2.8kW		PCS	1	----		(1)(3)	
35	EH1 EH2	电热/Heater		SHINI		----		400V 50Hz 12kW		PCS	2	----		(1)	
Notes: (1)Means it 's not the material inside the control box (2) Stand for optional return water and water outlet temperature display function (3)Means equipped with magnetic pump, (4)Means optional air-blowing cleaning function (5) Optional flow meter and pressure meter															
STM-2440W 版本Ver.G		STM-2440MW 版本Ver.G		STM-2440WA 版本Ver.F		注: (1)表示非电控箱内材料;(2)表示选配出水 and 回水温度显示功能;(3)表示选配磁力泵浦;(4)表示选配气吹排空功能;(5)表示选配流量,压力计。									
				制图		版号		J		标题		STM-2440W		图号	
				设计		核				电气元件明细表二		STM-2440W-CE-400V-J-1		比例	
				校对		准				 信易電熱機械股份有限公司 Shini Plastics Technologies, Inc.		标准		CE	
标记		更改前		更改后		更改人		日期				日期		202301114	
												机器电压		3φ400V	
												机器频率		50Hz	
1		2		3		4		5		6		7		8	

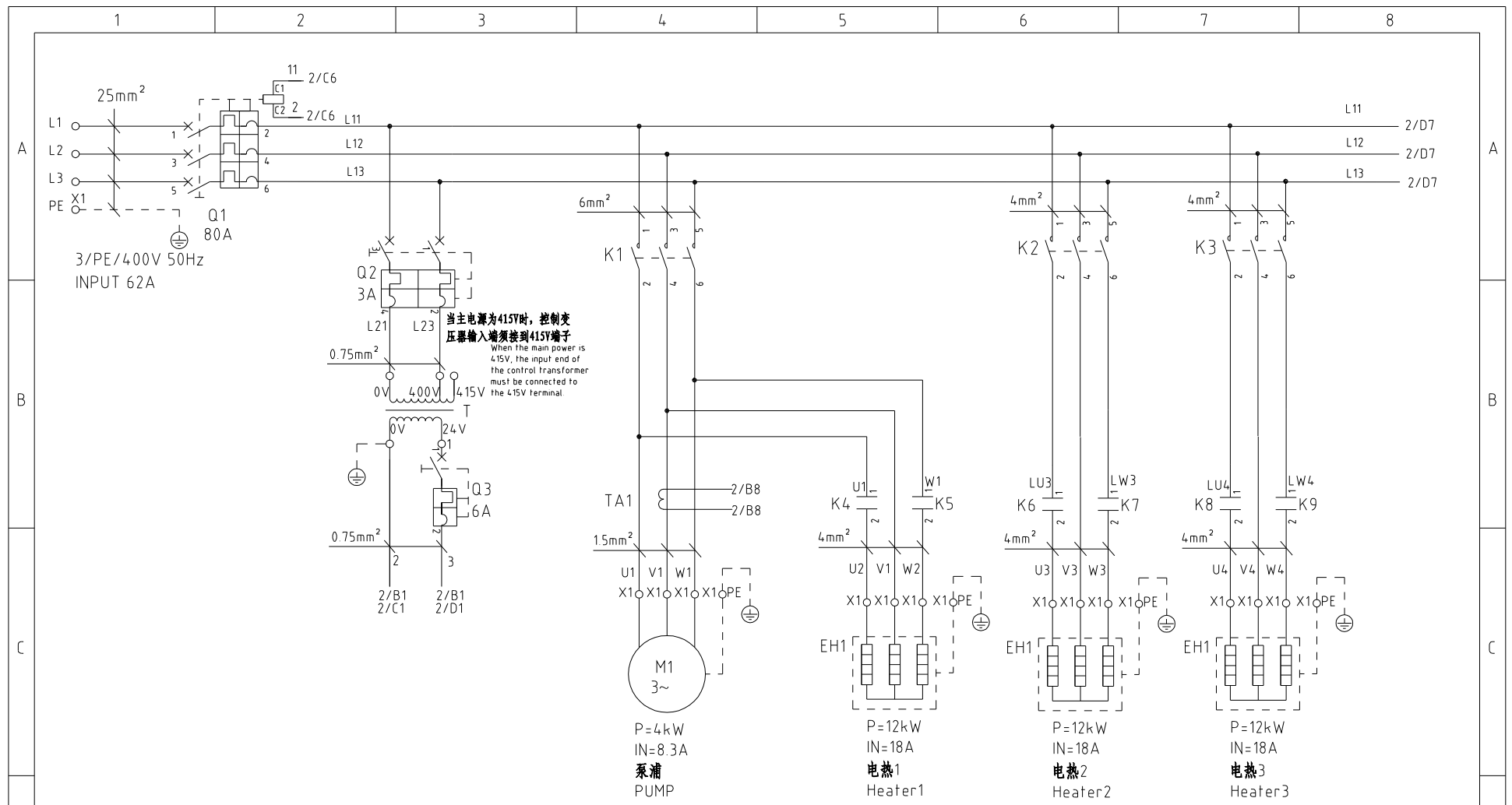

STM-3650W	版本 Ver.G
STM-3650WA	版本 Ver.F

					制图	版号 H	标题 STM-3650W	图号 STM-3650W-CE-400V-H-1	比例	第 1 张
					设计	核准	主电路图		标准 CE	共 7 张
					校对	日期 20230114	信易电热机械股份有限公司 Shini Plastics Technologies, Inc.	机器电压	3φ400V	
标记	更改前	更改后	更改人	日期	审核	日期		机器频率	50Hz	

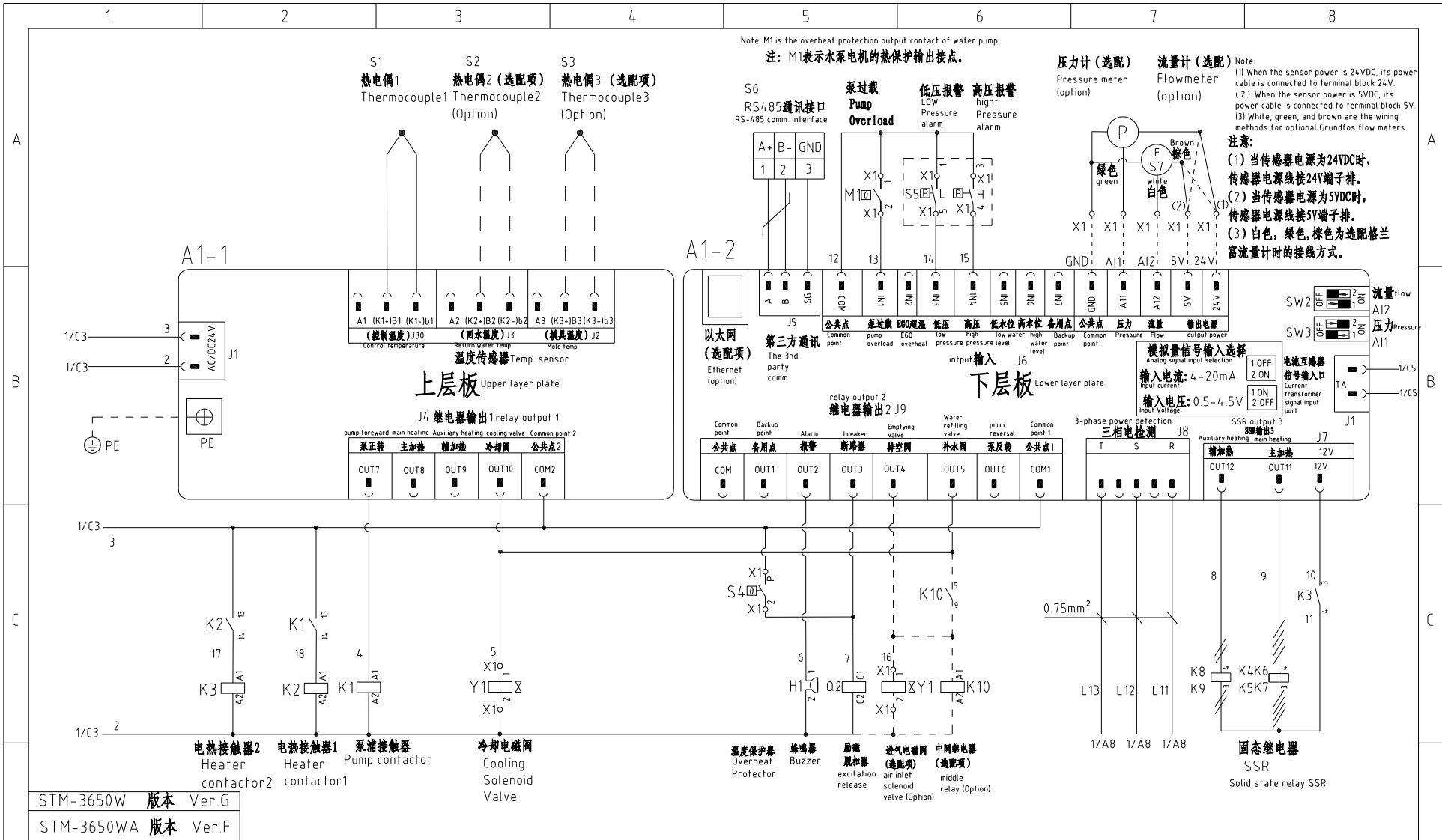

Note: M1 is the overheat protection output contact of water pump.
 注: M1表示水泵电机的热保护输出接点。

压力计 (选配) Pressure meter (option)
流量计 (选配) Flowmeter (option)
 Note:
 (1) When the sensor power is 24VDC, its power cable is connected to terminal block 24V.
 (2) When the sensor power is 5VDC, its power cable is connected to terminal block 5V.
 (3) White, green, and brown are the wiring methods for optional Grundfos flow meters.

注意:
 (1) 当传感器电源为24VDC时, 传感器电源线接24V端子排。
 (2) 当传感器电源为5VDC时, 传感器电源线接5V端子排。
 (3) 白色, 绿色, 棕色为选配格兰流量计时的接线方式。

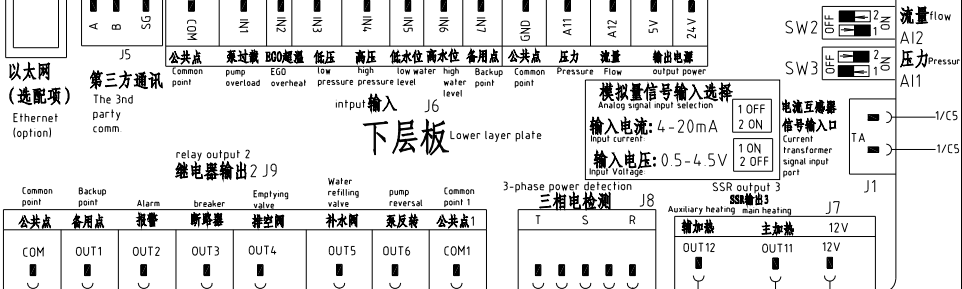

STM-3650W 版本 Ver.G		STM-3650WA 版本 Ver.F		制图	版号	H	标题	STM-3650W	图号	STM-3650W-CE-400V-H-2	比例	第 2 张
				设计	核准		控制电路图				标准	共 7 张
				校对	日期		信易电热机械股份有限公司 Shini Plastics Technologies, Inc.			机器电压	3φ400V	
标记	更改前	更改后	更改人	日期	审核	日期		20230114			机器频率	50Hz

信易辅机RS-485通讯接线示意图

Shini auxiliary machine RS-485 comm. wiring diagram

信易辅机(从站) Shini auxiliary machine (slave station)

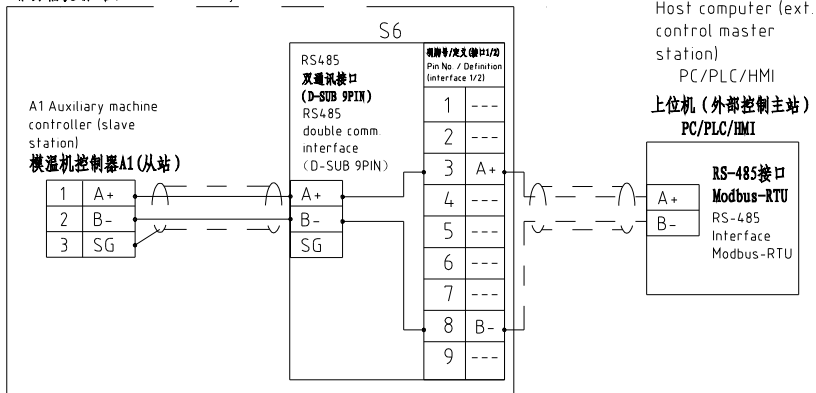

信易RS-485接口定义
Shini RS-485 interface definition

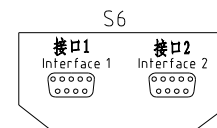

D-sub-9 接口 D-sub-9 pin interface	引脚号 Pin No	引脚定义 Pin definition
	1	—
	2	—
	3	A+ (RS-485 信号) A+ (RS-485 signal)
	4	—
	5	—
	6	—
	7	—
	8	B- (RS-485 信号) B- (RS-485 signal)
	9	—

- 注: 1. 通讯接口: RS-485 (两线式)
2. 通讯协议: Modbus-RTU
3. 机器配备D-sub9母接头, 接口1和接口2内部并联, 功能相同, 不分主次;

Note
1 Comm. interface RS-485 (two wire)
2 Comm. protocol: Modbus-RTU
3 The machine is equipped with D-sub9 female connector; interface 1 and interface 2 are connected in parallel and have the same function, which is regardless of primary and secondary.

STM-3650W 版本 Ver.G

STM-3650WA 版本 Ver.F

						制图	版号	H	标题	STM-3650W	图号	比例	第 3 张
						设计	核		通讯接线图	STM-3650W-CE-400V-H-3	标准	CE	共 7 张
						校对	准		信易電熱機械股份有限公司 Shini Plastics Technologies, Inc.	机器电压	3φ400V		
标记	更改前	更改后	更改人	日期	审核	日期	202301114	机器频率		50Hz			

1

2

3

4

5

6

7

8

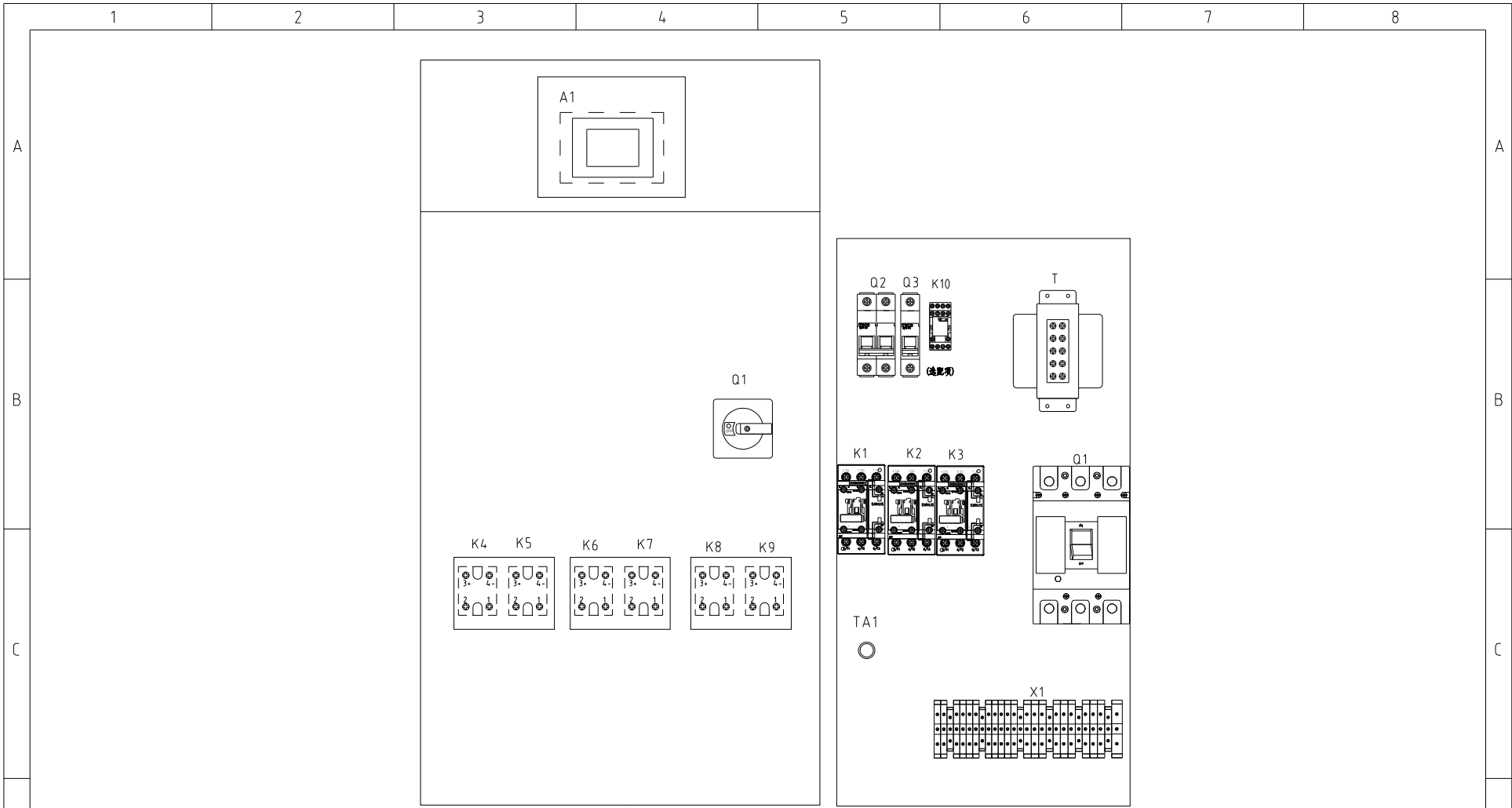

Control box outer case

电控底板 Base plate of control box

STM-3650W	版本	Ver.G
STM-3650WA	版本	Ver.F

Tech Req:
Aluminum cooler grounding wire
技术要求: 铝散热器接地线。

电控外箱

					制图		版号	H	标题	STM-3650W	图号	比例	第 4 张
					设计		核		电气布置图	STM-3650W-CE-400V-H-4	标准	CE	共 7 张
					校对		准		 信易電熱機械股份有限公司 Shini Plastics Technologies, Inc.	机器电压	3φ400V		
标记	更改前	更改后	更改人	日期	审核	日期	202301114	机器频率		50Hz			

Note
 (1) When the sensor power is 24VDC, its power cable is connected to Terminal block Z4V.
 (2) When the sensor power is 5VDC, its power cable is connected to terminal block 5V

注意:
 (1) 当传感器电源为24VDC时, 传感器电源线接24V端子排。
 (2) 当传感器电源为5VDC时, 传感器电源线接5V端子排。

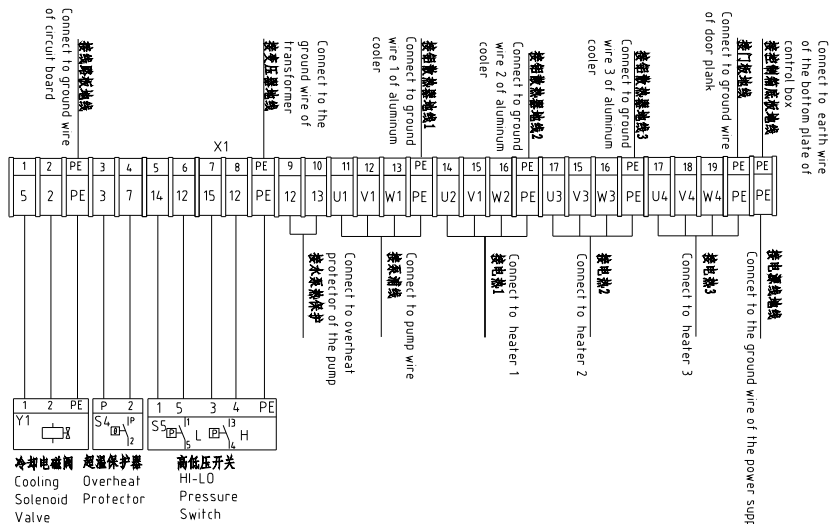
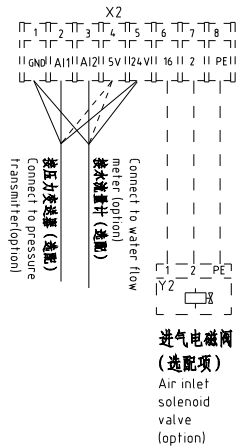

STM-3650W	版本	Ver.G
STM-3650WA	版本	Ver.F

D	制图	版号	H	标题	STM-3650W	图号	STM-3650W-CE-400V-H-5	比例	第 5 张
	设计	核准		端子接线图			标准	CE	共 7 张
	校对	日期	202301114	信易电热机械股份有限公司 Shini Plastics Technologies, Inc.	机器电压	3φ400V			
	标记	更改前	更改后		更改人	日期	审核	机器频率	50Hz

1		2		3		4		5		6		7		8						
序号/NO	符号/Symbol	名称/Name		制造商/Manufacturer		型号/Type		规格/Specification		单位/unit	数量/Number	物料编号/Material number		备注/Remark						
A	1	Q1	门连锁断路器/Break Interlock		TECO		FBB0100EB3080		80A		PCS	1.000	YE40100300300							
	2		断路器外部操作把手/External circuit breaker handle		TECO		1A-CS1-C-D1		B0100EB		PCS	1.000	YE90111100100							
	3		脱扣器/Trippler		TECO		FB1AS-AC024-L		AC24V(B0100EB)		PCS	1.000	YE90102400100							
	4	Q2	断路器/Circuit Breakers		TECO		BM-63C/2003S 2P		3A		PCS	1.000	YE40100203000							
	5	Q3	断路器/Circuit Breakers		TECO		BM-63C/1006S 6A 1P		3A		PCS	1.000	YE40100600100							
	6	K1K2K3	接触器/Contactors		SIEMENS		3RT6023-1AC20		24VAC		PCS	3.000	YE00602301100							
	7	K4K5K6K7K8K9	固态继电器/Solid-State Relay		FOTEK		KSR-40DA-H		40A/480VAC/4-32VDC		PCS	4.000	YE03404003200							
B	8	K10	中间继电器/middle relay		HONEYWELL		GR-2C-AC24V		24VAC		PCS	1.000	YE03022400300		(3)					
	9	T	互感器/Sensor thranformer		JIUXIN		IN=400V/415V OUT=24V		180VA		PCS	1.000	YE70040006700							
	10	S6	通信接口板RS-485 (双Dsub-9pin接头) Communication interface board RS-485 (double Dsub-9pin connector)		YUYUN		----		----		PCS	1.000	YR40048500000							
	11		外壳RS485 (SAL-700G-A-19) 0版 Shell RS485(SAL-700G-A-19)0		BINCHENG		----		----		PCS	1.000	YE84003500600							
	12	A1	线路板/Circuit Board		PUNP		STM-O/-W(24VAC)		SF518501A.03		ST	1.000	YE81245100100							
	13	H1	蜂鸣器/Buzzer		JINGKANG		PK-35A		24VAC/DC		PCS	1.000	YE84003500600							
	14	X1	端子排/Terminal Board		HONEYWELL		SK2.5		2.5mm ²		PCS	13.000	YE60002503400							
C	15		接地端子排/Grounding terminal board		HONEYWELL		SK2.5PE		2.5mm ² PE		PCS	3.000	YE60002503200							
	16		端子排/Terminal Board		HONEYWELL		SK4		4mm ²		PCS	9.000	YE60000403200							
	17		接地端子排/Grounding terminal board		HONEYWELL		GK5PE		5mm ² PE		PCS	3.000	YE60000403500							
	18		接地端子排/Grounding terminal board		HONEYWELL		GK16PE		16mm ² PE		PCS	1.000	YE60001603500							
	19	X2	端子排/Terminal Board		HONEYWELL		SK2.5		2.5mm ²		PCS	2.000	YE60002503400							
	20		接地端子排/Grounding terminal board		HONEYWELL		SK2.5PE		2.5mm ² PE		PCS	1.000	YE60002503400		(3)					
	21		接地端子排/Grounding terminal board		HONEYWELL		SK2.5PE		2.5mm ²		PCS	2.000	YE60000003900		(3)					
	22		终端固定件E/CN系列(霍尼韦尔) Terminal fittings E/CN series (honeywell)		HONEYWELL		----		----		PCS	6.000	YE60000003900		(4)					
	23		铝散热器 aluminum cooler		SHINI		----		----		BA	3.000	YW90120700000							
	24	TA1	单电流互感器 Single current transformer		PUNP		LGW122C		1		PCS	1.000	YE04012204400							
25	S1	热电偶/Thermocouple		SHINI		----		----		PCS	1	----		(1)						
STM-3650W 版本 Ver.G		STM-3650WA 版本 Ver.F		注: (1)表示非电控箱内材料; (2)表示选配出水和水温显示功能; (3)表示选配气吹清洁功能; (4)表示选配流量、压力计。 Notes: (1)Means it's not the material inside the control box. (2) Stand for optional return water and water outlet temperature display function. (3)Means optional air-blowing cleaning function. (4) Optional flow meter and pressure meter.																
D					制图		版号		H		标题		STM-3650W		图号		比例		第 6 张	
					设计		核				电气元件明细表一		STM-3650W-CE-400V-H-6		标准		CE		共 7 张	
					校对		准				 信易电热机械股份有限公司 Shini Plastics Technologies, Inc.		机器电压		3φ400V					
	标记		更改前		更改后		更改人		日期				202301114		机器频率		50Hz			
1		2		3		4		5		6		7		8						

1		2		3		4		5		6		7		8					
序号/NO	符号/Symbol	名称/Name		制造商/Manufacturer		型号/Type		规格/Specification		单位/unit	数量/Number	物料编号/Material number		备注/Remark					
26	S2 S3	热电偶/Thermocouple		SHINI		----		----		PCS	2	----		(1)(2)					
27	S4	超温保护器/Overheat Protector		----		----		----		PCS	1	----		(1)					
28	S5	高低压开关/Hi-L0 pressure switch		----		----		----		PCS	1	----		(1)					
29	Y1	电磁阀/Solenoid Valve		----		----		24 VAC 50/60Hz		PCS	1	----		(1)					
30	Y2	电磁阀/Solenoid Valve		----		----		24 VAC		PCS	1	----		(1)(3)					
31	M1	马达/Motor		SHINI		TP-400		400V 50Hz 4.0kW		PCS	1	----		(1)					
32	EH1 EH2 EH3	电热/HEATER		SHINI		----		400V 50Hz 12kW		PCS	3	----		(1)					
Notes: (1)Means it 's not the material inside the control box (2) Stand for optional return water and water outlet temperature display function (3)Means optional air-blowing cleaning function (4) Optional flow meter and pressure meter.																			
STM-3650W 版本Ver.G		STM-3650WA 版本Ver.F		注: (1)表示非电控箱内材料;(2)表示选配出水 and 回水温度显示功能;(3)表示选配气吹排空功能;(4)表示选配流量,压力计..															
				制图		版号		H		标题		STM-3650W		图号		比例		第 7 张	
				设计		核				电气元件明细表二		STM-3650W-CE-400V-H-7		标准		CE		共 7 张	
				校对		准				 信易電熱機械股份有限公司 Shini Plastics Technologies, Inc.		机器电压		3φ400V					
标记		更改前		更改后		更改人		日期				日期		202301114		机器频率		50Hz	
1		2		3		4		5		6		7		8					