

SG-24T

Screenless Granulator

Date: Sep, 2017

Version: Ver.B (English)



Contents

1. General Description	7
1.1 Coding Principle	8
1.2 Feature	8
1.3 Technical Specifications	10
1.4 Safety Regulations	11
1.4.1 Safety Signs and Labels	11
1.4.2 Transportation and Storage of the Machine	12
1.5 Exemption Clause	14
2. Structural Features and Working Principle	15
2.1 General Description	15
2.1.1 Working Principle	15
2.2 Safety System	16
2.2.1 Emergency Stop	16
2.2.2 Safety Switch	17
2.2.3 Gate Lock	17
2.3 Options	18
2.3.1 30-second Instant Recycling System	18
2.3.2 Full-receiver Alarm Devices	18
2.3.3 Regrind Conveying via Blower & Cyclone (BC Type)	19
2.3.4 Dust Separator (DS Type)	19
2.3.5 Proportional Valves	19
2.3.6 Collection Bin	19
3. Installation and Debugging	20
3.1 Installation Notice	21
3.2 Installation Place	23
3.3 Installation of Bearing and Blade Rest	23
3.4 Installation of Coupling and Motor	24
3.5 Installation of Rotating Blade and Fixed Blade	25
3.6 Installation of Feed Box, Feed Port and Storage Bin	27
4. Operation Guide	28

4.1	Startup Pretest	28
4.1.1	Before the First Startup.....	28
4.1.2	After Startup for 2 Hours.....	28
4.1.3	After Startup for 20~30 Hours.....	29
4.2	Circuit Connection.....	29
4.3	Open the Feed Box and Storage Bin	29
4.3.1	Open the Feed Box.....	29
4.3.2	Open the Storage Bin	30
4.4	Shut the Feed Box and Storage Bin.....	30
4.4.1	Shut the Feed Box.....	30
4.4.2	Shut the Storage Bin.....	30
4.5	Start and Stop the Granulator	31
4.6	Motor Reversed Protective Function.....	32
5.	Trouble-shooting	33
5.1	Granulator Can Not Work.....	33
5.2	Stop Due to Other Reasons	34
6.	Maintenance and Repair	35
6.1	Repair	35
6.1.1	Replace the Blades.....	35
6.2	Maintenance of Reduction Gear.....	38
6.3	Maintenance	39
6.3.1	Daily Check	39
6.3.2	Weekly Check.....	39
6.3.3	Monthly Check.....	40
6.4	Cleaning.....	40
6.5	Maintenance Schedule.....	41
6.5.1	About the Machine.....	41
6.5.2	Check After Installation.....	41
6.5.3	Daily Check	41
6.5.4	Weekly Check.....	41
6.5.5	Monthly Check.....	41
6.5.6	Check Half-yearly or Every 1000 Running Hours	42
6.5.7	3 year Checking.....	42

Table index

Table 1-1: Technical Specifications.....	10
--	----

Picture index

Picture 1-1: Dimensions	10
Picture 2-1: Working Principle	15
Picture 2-2: Safety System	16
Picture 2-3: Emergency Stop.....	16
Picture 3-1: Installation Notice	21
Picture 3-2: Installation Place	23
Picture 3-3: Installation of Bearing and Blade Rest 1.....	23
Picture 3-4: Installation of Bearing and Blade Rest 2.....	23
Picture 3-5: Installation of Bearing and Blade Rest 3.....	24
Picture 3-6: Installation of Gear Motor 1	24
Picture 3-7: Installation of Gear Motor 2	24
Picture 3-8: Installation of Rotating Blade and Fixed Blade 1	25
Picture 3-9: Installation of Rotating Blade and Fixed Blade 2	26
Picture 3-10: Installation of Rotating Blade and Fixed Blade 3.....	26
Picture 3-11: Installation of Feed Box, Feed Port and Storage Bin 1.....	27
Picture 3-12: Installation of Feed Box, Feed Port and Storage Bin 2.....	27
Picture 3-13: Installation of Feed Box, Feed Port and Storage Bin 3.....	27
Picture 4-1: Open the Feed Box	30
Picture 4-2: Main Power Switch	31
Picture 4-3: START, Emergency Stop and STOP Button	31
Picture 4-4: Motor Reversed Protection.....	32
Picture 6-1: Blades Maintenance.....	36
Picture 6-2: Dismantle Fixed Blades.....	37
Picture 6-3: Dismantle Rotate Blades	37
Picture 6-4: Star Screws	39
Picture 6-5: Machine Cleaning.....	40

1. General Description



Please read this manuals carefully before using this machine in order to operate correctly against any damage caused due to improper operation.



Note!

Always take great care when the knives are within reach, they are very sharp and can cause personal injury.



Forbidden to process flammable or toxic material!

SG-24T series granulator operate in super low speed to cut materials into well-proportioned granules. There are least dusts produced in the cutting process. Multiple security devices ensure high safety grade; automatic reverse running function ensures continuous operation. This series of screenless granulator are suitable for granulating hard and thick materials. For SG-24T series, there are two gear motors and two cutting chambers to work simultaneously. It can granulate the sprues and waste material, also is capable of granulating long and thin or tough sprues.



Model: SG-2446T

1.1 Coding Principle

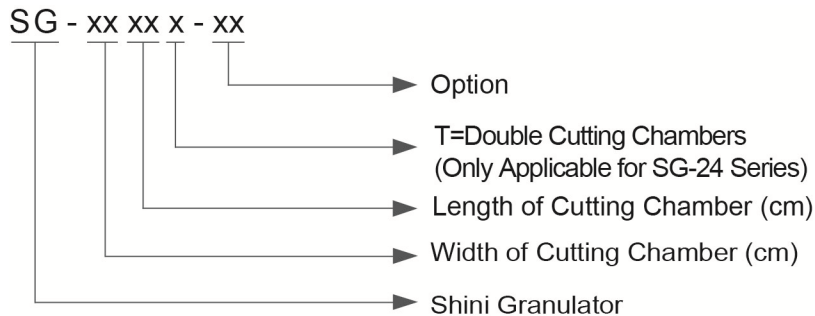

1.2 Feature

- SG-24T series have two German-made gear motors and two cutting chambers working simultaneously to provide reliable performance and high torque.
- SG-24T series feature integral design of double teeth cutters and cutting blades. Staggered blades make the initial cutting and teeth cutters reduce the materials into desired size. Regrinds could be used with virgin materials.
- New-type inclined teeth cutter reduces the possibility of stress concentration, enhance bearing capacity and converts force direction so that cutter lifespan can be prolonged.
- SG-24T series motor shaft and rotor shaft are connected by shaft coupling thus ensuring smooth cutting action and convenient motor replacement.
- When motor blockage occurs, the machine will alarm visibly and enable motor to run reversely. It resumes normal operation automatically after the trouble is clear.
- European type appearance, compact in size and easy to access for cleaning and maintenance.
- Transparent PC feeding hopper.
- Screenless design, well-proportioned size of regrinds and least amount of dusts. Regrinds could be used with virgin materials.

All service work should be carried out by a person with technical training or corresponding professional experience. The manual contains instructions for both handling and servicing. Chapter 6, which contains service instructions intended for service engineers. Other chapters contain instructions for the daily operator.

Any modifications of the machine must be approved by SHINI in order to avoid personal injury and damage to machine. We shall not be liable for any damage caused by unauthorized change of the machine.

Our company provides excellent after-sales service. Should you have any problem during using the machine, please contact the company or the local vendor.

Headquarter and Taipei factory:

Tel: (886) 2 2680 9119

Shini Plastics Technologies (Dongguan), Inc:

Tel: (86) 769 8111 6600

Shini Plastics Technologies India Pvt.Ltd.:

Tel: (91) 250 3021 166

1.3 Technical Specifications

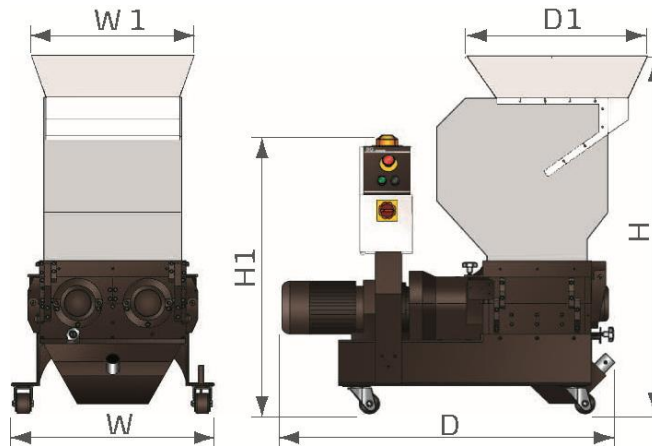

Picture 1-1: Dimensions

Table 1-1: Technical Specifications

Model	SG-2436T	SG-2446T
Ver.	B	B
Motor Power (kW, 50/60Hz)	2.2×2/2.55×2	2.2×2/2.55×2
Rotating Speed (rpm, 50/60Hz)	27/33	27/33
Material of Teeth Cutters	SKD11	SKD11
Number of Cutting Blades	7	9
Number of Large Teeth Cutlers	7	9
Number of Small Teeth Cutlers	2	2
Cutting Chamber (mm)	505×365	505×460
Max. Throughput Capacity (kg/hr, 50/60Hz)	20	25
Noise Level dB(A)	67~75	70~78
Dimensions		
H (mm)	1360	1360
H1 (mm)	1060	1060
W (mm)	773	773
W1 (mm)	620	620
D (mm)	1269	1365
D1 (mm)	688	785
Weight (kg)	530	560

Note: 1) Max. Capacity of the machine is subject to the size and composition of the material.

2) Noise level will vary with different materials.

3) SKD11 is JIS steel grade.

4) Trapezoidal teeth cutter is standard; narrow and dilated one are optional (SG-14N/24T).

5) To avoid plastic from sticking to the blades, all materials should be crushed at normal temperature.

6) Power supply: 3Φ, 230 / 400 / 460 / 575VAC, 50 / 60Hz.

1.4 Safety Regulations

Follow the instructions in this manual to avoid personal injury and damage to machine components.

The following safety measures shall be followed when operating the granulator.

1.4.1 Safety Signs and Labels



Electrical installation must only be done by a competent electrician!



Before the granulator is opened for servicing and maintenance, always disconnect the power with both the main switch and the control switch on the granulator.



Never put any part of your body through the granulator openings, unless both the main switch and the control switch on the granulator are in "OFF" position.



High voltage! danger!

This sign is attached on the control box and the wiring box.



Be careful with the rotating knives, they are very sharp and can cause personal injury!



The granulator should not be started before the feed box and storage box are properly closed.



Attention please!

Ear protection is used during granulating of plastic materials.



Make sure the power has been cut off before open the feed box.



Attention!

No need for regular inspection because all the electrical parts in the control unit are fixed tightly!

1.4.2 Transportation and Storage of the Machine

Transportation

- 1) SG-24T series of granulator are packed in plywood cases with wooden pallet at the bottom, suitable for quick positioning by fork lift.
- 2) After unpacked, castors equipped on the machine can be used for ease of movement.
- 3) Do not rotate the machine and avoid collision with other objects during transportation to prevent improper functioning.
- 4) The structure of the machine is well-balanced, although it should also be handled with care when lifting the machine for fear of falling down.
- 5) The machine and its attached parts can be kept at a temperature from -25°C to $+55^{\circ}\text{C}$ for long distance transportation and for a short distance, it can be transported with temperature under $+70^{\circ}\text{C}$.

Storage

- 1) SG-24T series should be stored indoors with temperature kept from 5°C to 40°C and humidity below 80%.
- 2) Disconnect all power supply and turn off main switch and exigency stop switch.
- 3) Keep the whole machine, especially the electrical components away from water to avoid potential troubles caused by the water.
- 4) Use plastic film to cover the machine tightly to prevent the machine from dust and rains.

Working environment

The machine should be operated:

- 1) Indoors in a dry environment with max. temperature $+45^{\circ}\text{C}$ and humidity no more than 80%.

Do not use the machine:



- 1) If it is with a damaged cord.
- 2) On a wet floor or when it is exposed to rain to avoid electric shock.
- 3) If it has been dropped or damaged until it is checked or fixed by a qualified serviceman.

- 4) This equipment works normally in the environment with altitude over 3000m.
- 5) At least 1m surrounding space is requested when this equipment is running. Keep this equipment away from flammable sources at least two meters.
- 6) In the work area of vibration and strong magnetic force.

Rejected parts disposal

When the equipment has run out its life time and can not be used any more, unplug the power supply and dispose of it properly according to local code.



Fire hazard!

In case of fire, CO₂ dry powder fire extinguisher should be applied.



Flammable materials or materials which are contaminated by flammable substances/liquid may not be processed in the granulator. Serious risk of fire or explosion may cause personnel injury.



It is very important to tighten the screw as required torque.



When process item is longer than feed port, please cut long items into half until the length is shorter before processing.



Please don't put materials into the granulator if they are thinner than 2 mm and are soft and flexible, like rubber.

1.5 Exemption Clause

The following statements clarify the responsibilities and regulations born by any buyer or user who purchases products and accessories from Shini (including employees and agents).

Shini is exempted from liability for any costs, fees, claims and losses caused by reasons below:

1. Any careless or man-made installations, operation and maintenances upon machines without referring to the Manual prior to machine using.
2. Any incidents beyond human reasonable controls, which include man-made vicious or deliberate damages or abnormal power, and machine faults caused by irresistible natural disasters including fire, flood, storm and earthquake.
3. Any operational actions that are not authorized by Shini upon machine, including adding or replacing accessories, dismantling, delivering or repairing.
4. Employing consumables or oil media that are not appointed by Shini.

2. Structural Features and Working Principle

2.1 General Description

SG-24N series are belong to "by the machine" granulator, which are designed for grinding small volume of plastic waste. Do not feed excessive materials during granulation. The granulator are controlled by main power switch, emergency stop button, start button, stop button and safety switches.

2.1.1 Working Principle

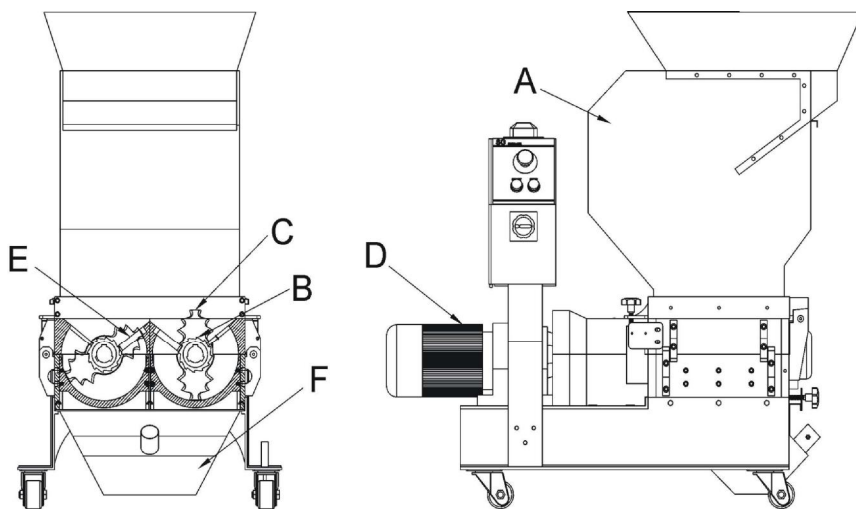

Parts name:

A. Feed box B. Teeth cutter C. Staggered blade D. Motor E. Fixed blade F. Storage bin

Picture 2-1: Working Principle

The material is fed in via a feed box (A) and falls down to the teeth cutters (B), the block material is cutted by the staggered (C) and fixed blades (E), then the material is cutted into granule by (B) and (E). The granule directly fall into the storage bin (F), it does not need the screen. The cutting chamber is easy to open for cleaning and maintenance. After this, the granulate is ready for re-use in the production machine, or to be transported to a container for later use.

2.2 Safety System

To avoid accidental bodily injury during granulator running, a set of safety system has been designed.

High-speed rotating cutter is located in the granulator and subject to accident. So safety system has been set up to protect bodily safety.

In any cases, the safety system cannot be changed at random. Otherwise the machine will be under dangerous condition and subject to accident happening. The maintenance and preservation of safety system shall be done by professional staff.

In case the safety system of granulator is changed, our company will not perform our commitment. The replacement of all spare parts will be done by SHINI Company.

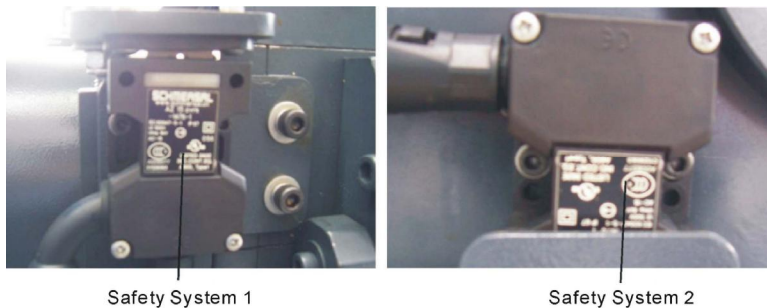

Picture 2-2: Safety System

2.2.1 Emergency Stop

There is one red button on the control panel. Upon pushing it, the machine will stop running. Turn the button in the arrow direction as shown on the button, the button will reset (counter-clockwise).



Picture 2-3: Emergency Stop

2.2.2 Safety Switch

On the granulator is equipped the safety position switch for circuit breaker. In case the position of feed box is changed or the breaker is loosened, it will cut off the power supply.

There are two safety switches on the granulator: one is located between the feed box and the cutting chamber while the other one is between the storage bin and machine body.

2.2.3 Gate Lock

For opening feed box and cutting chamber, users need to loosen a long star screw (gate lock). It takes some time to unscrew the lock to completely stop cutter shaft and avoid personal injuries.

Notice before startup:

- 1) Check if feed box is tightened.
- 2) Close feed box and tighten star screw.
- 3) Check if plug of storage bin safety switch is tightened

2.3 Options

2.3.1 30-second Instant Recycling System

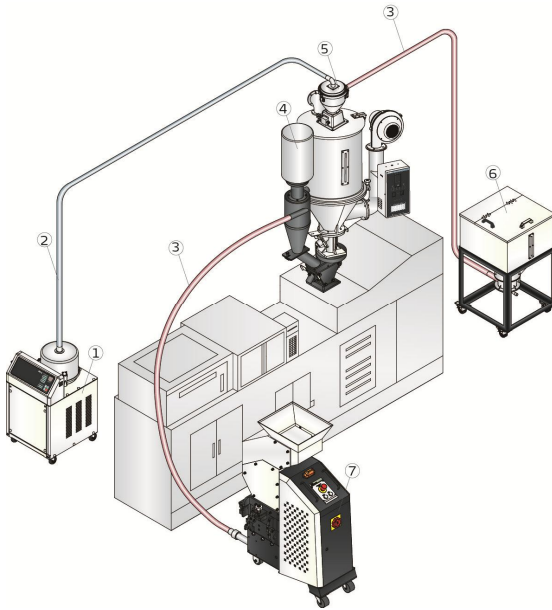

VR Type 30-Sec Instant Recycling

- 1. Hopper loader
- 2. Vacuum pipe
- 3. Material pipe
- 4. 30-Sec instant recycling system
- 5. Vacuum hopper
- 6. Material tank
- 7. Screenless granulator

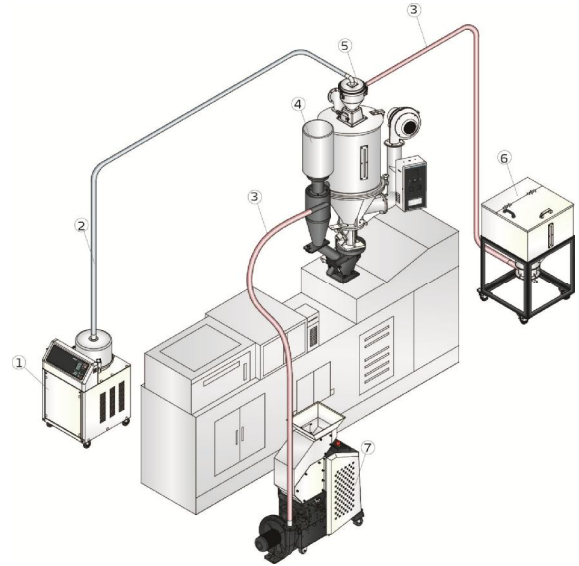

BR Type 30-Sec Instant Recycling

2.3.2 Full-receiver Alarm Devices



Full-receiver alarm device can help to realize unmanned operation and no materials will be wasted. Whenever the regrind level reaches the motor position, the machine will be forced to stop and be cut off via its sensor, thus stop the granulator and warn the user by sounding an alarm. Applicable to SG-24N/24T series.

2.3.3 Regrind Conveying via Blower & Cyclone (BC Type)



This device utilizes loading blower to convey regrind into the cyclone dust collector to separate the regrind from the air and then the regrind will fall into storage hopper or cloth bag. Applicable to SG-24N/24T series.

2.3.4 Dust Separator (DS Type)

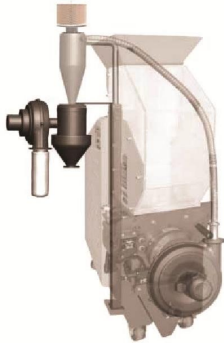

Dust Separator (DS type) can separate the dust in the regrind for immediate recycle use. The dust will be kept in filter bag, thus working environment will be maintained clean. This device ensures full use of regrind to avoid material wasting and enhance the economical returns. Applicable to SG-24N/24T series.

2.3.5 Proportional Valves



Proportional valves mix regrind with new materials in a proper proportion, and then send them back to the IMM. It features easy installation and excellent accuracy. For details, please refer to the brochure of SPV-U. Applicable to SG-24N/24T series.

2.3.6 Collection Bin



Manual collection bin helps to collect and store regrind. Applicable to SG-24T series.

3. Installation and Debugging



Read through this chapter before installation.



Must abide by the following installation steps to avoid personnel injuries or damage of the machine!



Take great care of handing the blades because they are very sharp and may cause cutting injuries!



Power supply of the machine should be handled by qualified electricians!



Be careful!

Cutting blades must be put balanced, prevent it to rotate itself when do the installation. Keep hands from blades to avoid body injuries!



Attention:

Don't take other person's help to finish the installation, use a wooden board to block the rotating blade to finish it.



Notice!

Use protective gloves since the blades are very sharp.



Caution!

Must use new screw and washer to install the blade.

3.1 Installation Notice

- 1) Make sure voltage and frequency of the power source comply with those indicated on the manufacture's plate, which is attached to the machine.
- 2) Power cable and earth connections should conform with local regulations.
- 3) Use independent power cable and ON / OFF switch. The cable's dia. Should not smaller than those applied in the control box.
- 4) The power cable connection terminals should be tightened securely.
- 5) The machine requires a 3-phase 4-wire power source, connect the power lead (L1, L2, L3) to the live wires, and the earth (PE) to the ground.
- 6) Power supply requirements:
 - Main power voltage: +/- 10%
 - Main power frequency: +/- 2%

Make at least 1 meter clearance around the machine to facilitate repair and maintenance.

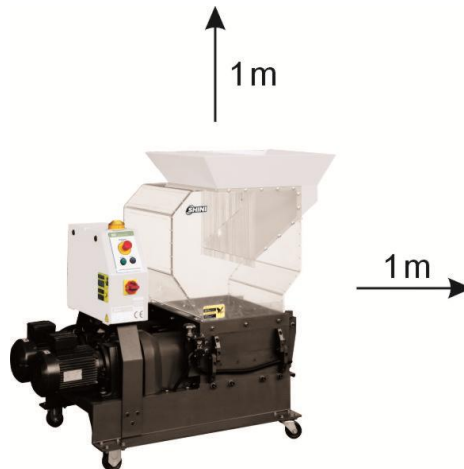

Picture 3-1: Installation Notice

Table 3-1: cutters and other fixing screw torque

Thread type	Thread spec.	Drawing force Fv(N)			Fixing torque Ma (N.M)		
		8.8	10.9	12.9	8.8	10.9	12.9
Coarse thread	M4	3900	5750	6700	3.0	4.4	5.1
	M5	6400	9400	11000	5.9	8.7	10
	M6	9000	1320	15500	10	16	18
	M8	16500	24300	28400	25	36	43
	M10	26300	38700	45200	49	72	84
	M12	38400	56500	66000	86	126	145
	M14	62500	77500	90500	135	200	236
	M16	72500	10700	12500	210	310	365
	M18	91000	129000	152000	300	430	600
	M20	117000	166000	195000	425	610	710
	M22	146000	208000	244000	580	820	960
	M24	168000	240000	281000	730	1050	1220
	M27	222000	316000	369000	1100	1550	1800
	M30	269000	384000	449000	1450	2100	2450
Fine thread	M8×1	18100	26600	31200	27	39	46
	M10×1.25	28300	41600	48700	52	76	90
	M12×1.25	43300	63500	74600	93	135	160
	M12×1.5	40800	60000	70000	89	130	155
	M14×1.5	58600	86000	100000	145	215	255
	M16×1.5	79500	116000	136000	226	330	390
	M18×1.5	108000	152000	177000	340	485	570
	M20×1.5	134000	191000	224000	475	680	790
	M22×1.5	166000	236000	276000	630	900	1050
	M24×2	189000	270000	316000	800	1150	1350
	M27×2	246000	350000	409000	1150	1650	1950
	M30×2	309000	440000	515000	1650	2350	2750

3.2 Installation Place

Check and make sure the installation ground is level; there is enough intensity when it is running. Lockup the castors.

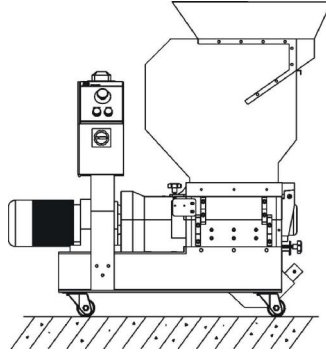

Picture 3-2: Installation Place

3.3 Installation of Bearing and Blade Rest

- 1) Install the bearing 2. bearing washer 1. bearing sleeve 7 into the bearing base 3.
- 2) Insert the blade shaft 4 into the bearing sleeve vertically 7. Then sleeve the staggered blade 5 and the teeth blade 6 on the bearing spacing.

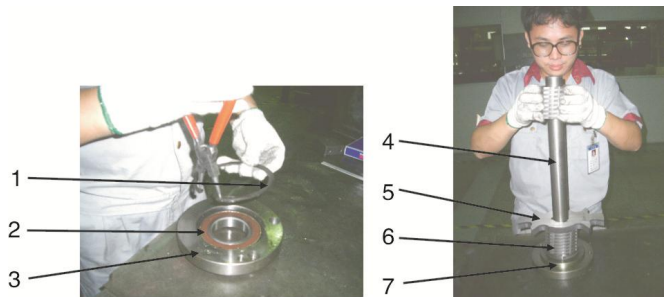

Picture 3-3: Installation of Bearing and Blade Rest 1

- 3) Put the blade rest 2 into the cutting chamber 1, let both terminals of the bearing tallies with the grooves.



Picture 3-4: Installation of Bearing and Blade Rest 2

- 4) Fix the bearing base on the cutting chamber.



Picture 3-5: Installation of Bearing and Blade Rest 3



Daub the lubrication on the bearing and bearing base. Use proper twisting force to lock the screw tightly.

3.4 Installation of Coupling and Motor



Notice!

To stop blade rest shaft rotating while installation, use a thick wood block to stuck rotate blades!

- 1) Firstly fit coupling on cutter shaft to match key groove holes with the cutter shaft key. At last, mount sensor and fasten it with inner hex bolt (M20x45).



Picture 3-6: Installation of Gear Motor 1

- 2) Firstly fit coupling 2 on cutter shaft to match key groove holes with the cutter shaft key. And then fasten the coupling via inner hex flat end set screw.

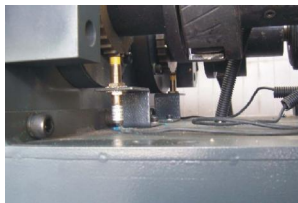

Picture 3-7: Installation of Gear Motor 2

- 3) Tightly fit coupling 1 and 2, fasten them on bottom plate via bolts and then fasten them on the bottom plate via cover plate.



Notice!

Do not apply lubricating oil on bearing and bearing base.



Notice!

To stop blade rest shaft rotating while coupling mount and installation, use a thick wood block to stuck rotate blades!



Caution!

The cutting blade rest shall be put stably and avoid cutter self-rotation. At the time of operating, hand shall stay away from the cutting tool to avoid bodily injury.

3.5 Installation of Rotating Blade and Fixed Blade



Attention!

Blades are extremely sharp; to avoid injuries, please wear gloves before and during installation.

Installation Steps:

- 1) Install the bearing 2, bearing washer 1, bearing sleeve 7 into the bearing base 3.
- 2) Insert the blade shaft 4 into the bearing sleeve vertically 7. Then sleeve the staggered blade 5 and the teeth blade 6 on the bearing spacing.

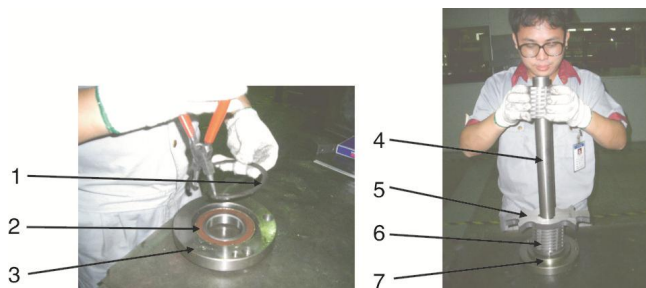

Picture 3-8: Installation of Rotating Blade and Fixed Blade 1

- 3) Put the rotating blade rest at the bottom block of the cutting chamber and align its holes with the holes on cutting chamber.



Picture 3-9: Installation of Rotating Blade and Fixed Blade 2

- 4) Use a wrench to tight up all the screws on bearing block or cutting chamber and lock them up with right torque (M12x25).
- 5) After installed the rotating blade rest to the housing, mount fixed blades that correspond with teeth cutters on pressing block and align their holes. Lockup the fixing screw (LOCTITE243 thread fixing glue is recommended). (Fixing screw for front fixed blade is M10x30, while for back fixed blade is M10x35).



Picture 3-10: Installation of Rotating Blade and Fixed Blade 3



Caution!

Gap between rotate and fixed blades is unadjustable. Please rotate therest after installation to check blade rest in oredr to avoid damage.



Caution!

In order to avoid personal injury and machine damage, the lockup screws has to be tightened.

3.6 Installation of Feed Box, Feed Port and Storage Bin

- 1) Lift up the feed box to fix it onto the cutting chamber with screws (M8×35).

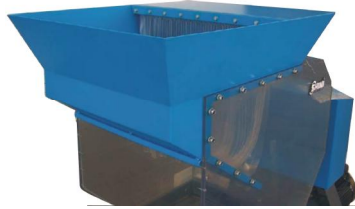

Picture 3-11: Installation of Feed Box, Feed Port and Storage Bin 1

- 2) Hold the feed port, and insert it into the feed box.

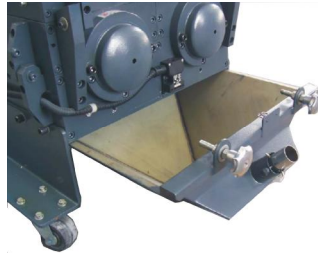

Picture 3-12: Installation of Feed Box, Feed Port and Storage Bin 2

- 3) Before fixing the feed port, place the plastic strips at the top of feed box and let feed port press against it.
- 4) Lay down the feed port and align its screw holes with the screw holes on the feed box, then lock the screws up (M8×20).



Picture 3-13: Installation of Feed Box, Feed Port and Storage Bin 3

- 5) Hold the storage bin with both hands and push it into its right position along the slide way.
- 6) Lock up plum blossom handle.

4. Operation Guide



Wear gloves during operating to avoid personal injury!



Wear goggles during operating to avoid personal injury!



Blade or rotor may be loose, make sure check them before operation:

- 1) Check if blades are damaged and loose;
- 2) Check if rotor is damaged and loose;

Please contact local agents or Shini Company if any situation above has been found.

4.1 Startup Pretest

Unpainted part of the machine has been covered with antirust oil. Before use, the antirust oil should be cleaned.

- 1) Clean with a towel.
- 2) Wash with a towel dipping with amyl acetate.

4.1.1 Before the First Startup

- 1) Check whether the granulator is in the level state.
- 2) Check the space of the cutting tools to see whether the lockup screws of the blades are tightened
- 3) Before granulation, ensure the rotation direction of main shaft is in line with that marked in nameplate.

4.1.2 After Startup for 2 Hours

- 1) Check the space of the cutting tools of the fixed blades and rotating blades again; check whether the lockup screws of the blades are loose.
- 2) Check the position-adjusting screws of the motor and check whether the position-adjusting screws are tightened.

4.1.3 After Startup for 20~30 Hours

After 20~30 hours machine running in full load, users need to check temperature on motor surface and check if there oil leaks.

4.2 Circuit Connection



Notice!

The installation of the granulator's circuit must be conducted by the professional electricians.

- 1) Check if feed box is fully closed;
- 2) Check if storage bin is fully closed;
- 3) Ensure the main power switch is in ON position.
- 4) Check if emergency stop is under action;
- 5) Start the granulator via pressing the START button and stop the granulator via pressing the STOP button.
- 6) The granulator needs some time to fully come to a halt; after full stop, check whether the running direction is clockwise.



The cutting tools may be damaged and the granulating capability will be reduced if there is a wrong running direction. Please disconnect the power and transpose any two wires of the three in the main power.

4.3 Open the Feed Box and Storage Bin



Notice!

Before opening the feed box and the storage bin, turn off the main power switch and the power switch of the granulator.



Be careful! The blade is very sharp, please take care.

4.3.1 Open the Feed Box

- 1) Check if the feed box has been emptied. If so, turn off the main power switch.
- 2) Loosen the long star screw and open the feed box.
- 3) Open feed box backwards.

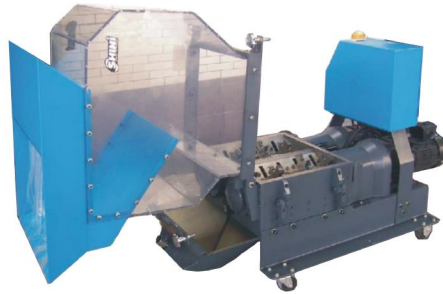

Picture 4-1: Open the Feed Box

4.3.2 Open the Storage Bin

- 1) Turn off granulator power.
- 2) Loosen long star screw.
- 3) Pull out storage bin.

4.4 Shut the Feed Box and Storage Bin

4.4.1 Shut the Feed Box



Notice!

Make sure feed box is fully closed, otherwise machine would not start.

- 1) Check to ensure there is no powder left in the interface or corners.
- 2) Close the feed box forwardly.
- 3) Lock up the star screw and fix the feed box.

4.4.2 Shut the Storage Bin



Note!

Before closing, clean the interface surface.

Be careful!

Don't get squeezed and injured.

- 1) Check no powder or leftover material around the storage box; timely remove them if any.
- 2) Push the storage bin inwards along its slideway.
- 3) Lock up long star screw and fix storage bin.

4.5 Start and Stop the Granulator

The granulator is controlled by main power switch, safety switch, START/STOP button and emergency stop button.

Main power switch is located at the front control panel. And the startup and stop of the machine is controlled through rotating the main power switch.



Picture 4-2: Main Power Switch

START button and STOP button:

These two buttons control the startup and stop of the machine.

Emergency stop:

This switch can protect and stop machine when accidents happens.

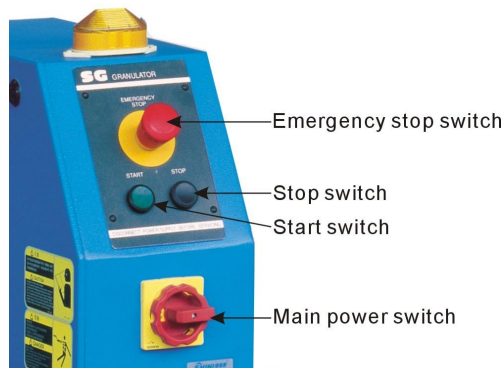

Picture 4-3: START, Emergency Stop and STOP Button



Caution!

If there are ungrinded materials in the feed box or cutting chamber, the granulator shall NOT be stopped, otherwise raw materials will block the rotor and the motor will be overloaded next time you start the machine up.

4.6 Motor Reversed Protective Function

When there are hard material appear in the feed box and cutting chamber or for other reason the cutting blades can not cut, this unit will enable blade shaft reverse rotating with alarm, it resumes normal operation automatically after 3 seconds later, so to keep granulating material. The alarm dies out after blade shaft rotates normally. If the motor reverse function be started over 3-4 times or more, the motor would be stopped. At this time you can press down the STOP button to cut off the power, and then restart it by press the START button.

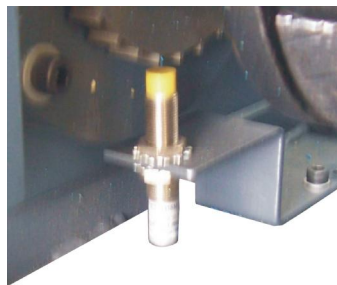

Picture 4-4: Motor Reversed Protection

If the rotor has been seized during operation, its working mode is:

Rotor is seized up, auto stop for 1 sec → reverse rotate for 3 secs → stop for 1 sec → normal rotate →

A. 1) normal → working

2) seized up → stop for 1 sec → reverse rotate for 3 secs → stop for 1 sec → normal rotate

B. 1) normal → working

2) seized up → stop for 1 sec → reverse rotate for 3 secs → stop for 1 sec → normal rotate

C. 1) normal → working

2) seized up → machine stops



Notice!

Mount sensor and ensure its space with big wheel to about 2~4mm.

5. Trouble-shooting

5.1 Granulator Can Not Work

- 1) Check if the emergency stop has been reset or not. If not, rotate the button anti-clockwise to reset it.
- 2) Check if the safety switch between feed box and storage box is completely closed. If not, machine can not be started.
- 3) Checking overload protector of the motor.

The overload protector in the electrical control box will work if the motor overloads. Test white key (A) turn left, press the “Reset” button (B) to reset it. Before it starts again, check whether there is any powder left in the granulator.

- 4) Check the overload protector of the feeding blower's motor.

If the feeding blower does not run, the granulator can run neither. Check the motor protector in the electric control box. If the protector is closed, the switch will be at “0” position, reset it to “1” position. Check if there’s no leftover, then re-start the machine. Test the white key(A) turn left, press” Reset” key (B) to reset it.

- 5) Check the clearance between the blades

The stop will happen or the motor overload protector will work if the blade is very blunt or the space between blades is not correct. Protector will be tripped if motor is overload. Blades should be checked, replaced or adjusted between the blades.

- 6) The contactor is burnt down or the control circuit is break off.



5.2 Stop Due to Other Reasons

Connection failure or looseness of safety switch can also cause shutdown



Note!

Do not disconnect to safety switch or control switch.

6. Maintenance and Repair

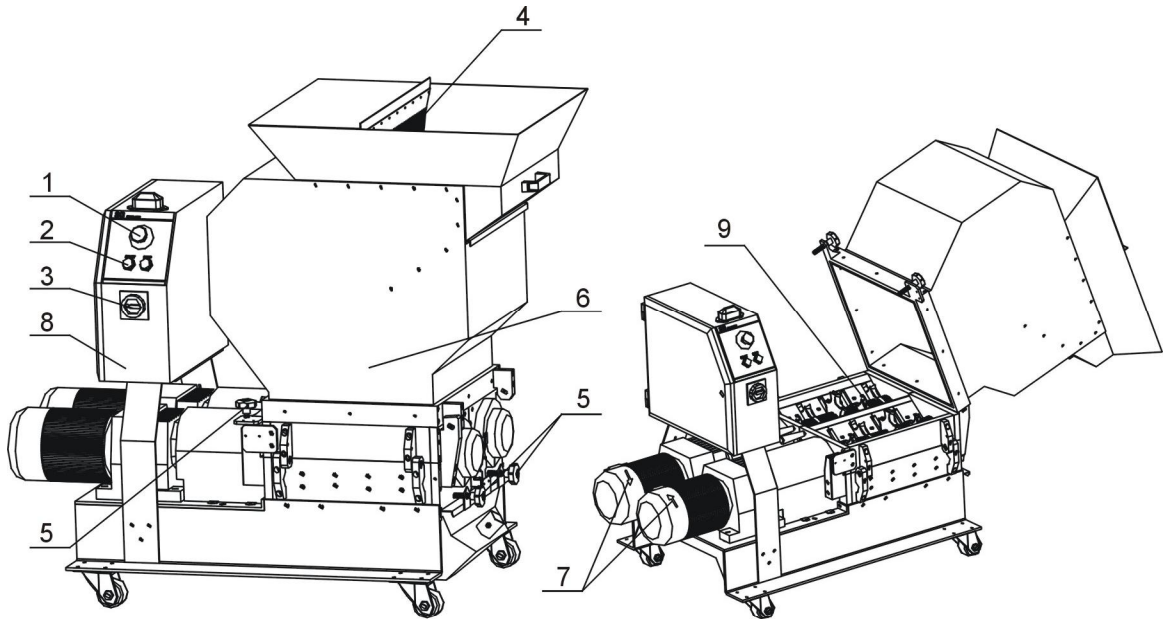

1. Check whether emergency stop works normally. Period: daily
2. Check whether START/STOP button works normally. Period: daily
3. Check whether main power switch works normally. Period: daily
4. Check whether material stopper is intact before startup. Period: daily
5. Check whether star screws in feed box and storage bin are tightened. Period: daily
6. Check whether there is metal in cutting chamber. Period: daily
7. Check whether cutter shaft rotates as showed in the nameplate. Period: daily
8. Check whether electric joints are loose in control cabinet. Period: weekly
9. Check whether fixed screws are loose. Period: monthly

6.1 Repair

All the repair must be done by professionals to avoid damage to machine and harm to human body.

6.1.1 Replace the Blades



Caution!

Self-rotation exists due to non-balanced forces.



Caution!

Self-rotation also happens when barycenter is unstable.

Wear gloves to avoid being cut and be careful of the sharp blades!



More details about replacing or maintaining the blades to see chapter 3.5. Inject screw thread fixing glue (light blue LOCTITE 243 recommended) to the fixing screw so to avoid slipping and tighten screws up.



Picture 6-1: Blades Maintenance



Caution!

To decrease the possibility of harm to other people, the replacement action must be conducted by oneself.



To avoid self-rotation, block the rotating blades with a thick wood block. Be careful with the sharp blades.



Each time to replace the blade, the screw and insulation ring must be replaced also.

1) Remove the fixed blades



Caution!

To avoid self rotation, block the rotating blade with a thick wood block.

1. Remove the set screws.
2. Remove the fixed blades.
3. Clean the installation surface of the blades.

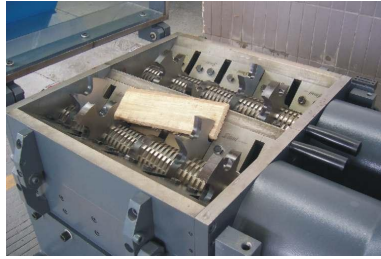

Picture 6-2: Dismantle Fixed Blades

2) Remove the rotating blades

1. Open the cutting chamber and loosen inner hex screws on bearing block.
2. Take out blade rest.
3. Clean the whole rotating blades and cutting chamber.

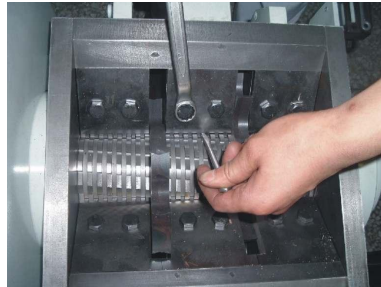

Picture 6-3: Dismantle Rotate Blades



Caution!

Press the pressing block and blade when you remove the last screw so to avoid personal injuries.

3) Install the blades

Clean carefully the fixed blades and rotating blades and then install them.



Caution!

Each time to replace the blade, the screw and insulation ring must be replaced also. Install the rotating blades, then the fixed blades, finally the front fixed blades. More details about replacing or maintaining the blades to see chapter 3.5.

6.2 Maintenance of Reduction Gear

Check lubricating oil for every six months or after 3000 hours in operation

1) Check oil level:

- a) Cut power off so to avoid electric shock and wait till the motor get cooled.
- b) Remove oil level plug to check if the oil has been filled up full.
- c) Install oil level plug.

2) Check the lubricating oil:

- a) Cut power off so to avoid electric shock and wait till the motor get cooled.
- b) Open oil drain plug to take samples.
- c) Check viscosity index of the lubricating oil.
If it is evidently turbid, please replace it as soon as possible.
- d) Check the lubricating oil level and install oil level plug.

3) Lubricating oil replacement: Increased viscosity of the lubricating oil will make it harder to discharge the oil, so better replace it when the motor is in its operational temp.

- a) Cut power off so to avoid electric shock.
- b) Lay an oil pan under the oil drainage plug.
- c) Open the oil level plug, air valve and oil drainage plug.
- d) Drain all the lubricating oil out.
- e) Install oil drainage plug.
- f) Fill in new lubricating oil in same brand.
- g) Tight up the oil level plug and air valve.

4) Brand of lubricating oils (ambient temperature : -10°C~40°C):

- Mobil: Mobilgear 630
Shell: Shell Omala 220
Aral: Aral Degol BG 220
BP: BP Energol GR-XP 220
Texaco: Meropa 220

6.3 Maintenance

When carrying out maintenance, ensure that there is no material left in the granulator.



Caution!

All repairing must be conducted by professionals to avoid personal injuries and machine damages!

6.3.1 Daily Check

- 1) There is rubber shutter in the feed box. If the rubber shutter is damaged, replace it immediately. Otherwise the fragment of the shutter will damage the blades in the cutting chamber.
- 2) Check whether the Emergency Stop works properly. Start the machine and then stop it via Emergency Stop. Rotate the button anti-clockwise to reset the Emergency Stop.
- 3) Check the main power switch, start/stop button.
- 4) Check the reversed rotating function.
- 5) Check star screw, safety screw is part of granulator' safety system, its length is pre-designed, when the screw is loosen, the granulator will stop working so to protect the machine. The thread length of the safety screw is 60mm, damaged screw needs to be replaced by a new one.

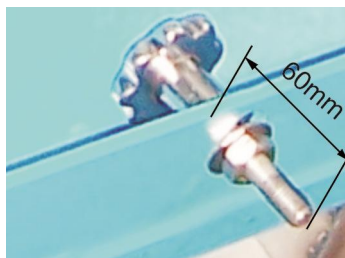

Picture 6-4: Star Screws

6.3.2 Weekly Check

- 1) Check the power wire to see whether there is any damage. If so, replace it immediately.
- 2) Check the safety switch.

3) Check whether there is looseness in electrical connections.

6.3.3 Monthly Check

- 1) Check whether coupling is damaged or not.
- 2) Check whether blades are loose or abraded.

6.4 Cleaning



Caution: The blade may do harm to human body when opening the feed box!

- 1) Check whether the feed box is emptied before stopping the machine.
- 2) Clean the exterior surface of the feed box.
- 3) Turn off the main power switch.
- 4) Clean the shutter of the feed box with a dust separator.
- 5) Unscrew the star knob to open the feed box backward.
- 6) Clean the interior surface of the feed box.
- 7) Unscrew star screw and take out storage bin.
- 8) Clean storage bin.
- 9) Clean both surfaces of the cutting chamber; open the upper cutting chamber and to clean the remained material by using revolving rod to turn the blade shaft.
- 10) Clean the belt pulleys with bright dust-precipitator.

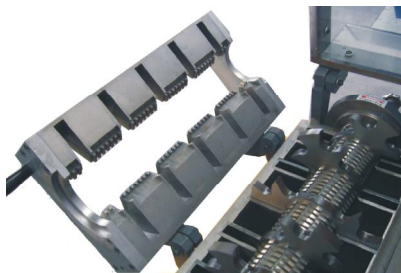

Picture 6-5: Machine Cleaning



Notice!

Finish step 9 for every time of machine cleaning and also it at least has to be done for one time after 300 hours in operation.

6.5 Maintenance Schedule

6.5.1 About the Machine

Model _____ SN _____ Manufacture date _____

Voltage _____ Φ _____ V Frequency _____ Hz Power _____ kW

6.5.2 Check After Installation

- Check if the lockup screws of the blades are locked firmly.
- Check if the star knob is firmly tightened.
- Check the rotating balance of the belt pulley.

Electrical Installation

- Voltage: _____ V _____ Hz
- Specs of the fuse: 1 Phase _____ A 3 Phase _____ A
- Check phase sequence of the power supply.

6.5.3 Daily Check

- Check main power switch.
- Check emergency stop button.
- Check start / stop button.
- Check material check plate (strip) is perfect or not.
- Check whether emergency stop and safety switch works normally.
- Clean screen and feeding hooper.
- Check whether start, stop and power switches are normal.

6.5.4 Weekly Check

- Check all the electrical cables.
- Check if there are loose connections of electrical components.
- Check blade condition.
- Check whether set screws in fixed and rotate blades are under looseness.
- Check if there is abnormal noise, vibration and heat in reduction gear.
- Check the cracking window

6.5.5 Monthly Check

- Check the status of the belt.
- Check the overload protection function of the motor.

- Check motor reversed running function.
- Check the tightness of the blades.
- Check whether clamp ring of pulley is fastened.
- Check belt tension.

6.5.6 Check Half-yearly or Every 1000 Running Hours

- Check or replace lubrication for gear motor.
- Check lubrication of bearing.
- Check coupling.
- Evaluation of the machine condition.

6.5.7 3 year Checking

- PC board renewal.
- No fuse breaker renewal.