

# **SAL-700G**

## **"Standard" Separate-vacuum Hopper Loader**

Date: Aug., 2021

Version: Ver.E





## Content

<b>1. General Description .....</b>	<b>5</b>
1.1 Coding Principle.....	5
1.2 Features.....	5
1.3 Technical Specifications .....	7
1.3.1 External Dimension .....	7
1.3.2 Specification .....	9
1.3.3 Loading Capacity.....	10
1.4 Safety Regulations.....	10
1.4.1 Safety Signs and Labels.....	10
<b>2. Structure Characteristics and Working Principle.....</b>	<b>11</b>
2.1 Working Principle .....	11
2.1.1 SAL-700G Working Principle.....	11
2.2 Accessory .....	12
2.3 Options .....	12
<b>3. Installation Layout.....</b>	<b>13</b>
3.1 Installation and Positioning .....	13
3.2 Power Connection.....	13
3.3 Air inlet/outlet .....	13
3.4 Installation steps of matching hopper.....	14
3.5 Installation of SAL-G Optional Cyclone Dust Separator.....	15
<b>4. Operation .....</b>	<b>18</b>
4.1 Panel Description.....	18
4.2 Parameter Setting.....	19
<b>5. Troubleshooting .....</b>	<b>23</b>
<b>6. Maintenance.....</b>	<b>24</b>
6.1 Hopper Cleaning (Take SVH as an example) .....	24
6.2 Main Body Cleaning.....	25

## Table Index

Table 1-1: SMH Specification .....	7
Table 1-2: SVH Specification.....	7
Table 1-3: Specification .....	9
Table 2-1: Description of detection device.....	12
Table 2-2: ACF Specification .....	12
Table 4-1: Panel Description .....	19
Table 4-2: Symbol status description.....	20
Table 4-3: Communication Address (Protocol Modbus-RTU) .....	21

## Picture Index

Picture 1-1: "Standard" Separate-vacuum Hopper Loader SAL-700G .....	5
Picture 1-2: SMH External Dimension .....	7
Picture 1-3: SVH External Dimension.....	7
Picture 1-4: SHR External Dimension.....	8
Picture 1-5: SAL-700G External Dimension .....	9
Picture 1-6: Loading Capacity .....	10
Picture 2-1: Working Principle .....	11
Picture 3-1: Air inlet / outlet .....	14
Picture 3-2: Use with SVH.....	14
Picture 3-3: Use with SMH .....	15
Picture 3-4: Use with SMH and SCH-U .....	15
Picture 3-5: Optional ACF-1 Installation Layout.....	16
Picture 3-6: ACF-1 Installation hole position.....	17
Picture 4-1: Panel.....	18
Picture 6-1: Hopper Cleaning .....	24
Picture 6-2: Host Unit Cleaning .....	25

# 1. General Description



Please read through this operation manual before using and installation to avoid damage of the machine and personal injuries.



Picture 1-1: "Standard" Separate-vacuum Hopper Loader SAL-700G

## 1.1 Coding Principle

SAL - xxx G

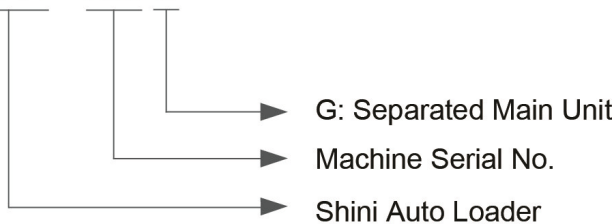

## 1.2 Features

- Microprocessor for ease of use and has multiple alarm indicators.
- Motor overload protector ensures long service life of motor.
- Audible material shortage alarm.
- Filter designed for easy cleaning and has filter status checking window for easier monitor of filter condition.
- Equipped with RS485 communication interface.

All maintenance work should be carried out by a person with technical training or corresponding professional experience. The manual contains instructions for both operating and maintenance. Chapter 6 contains maintenance instructions for service engineers. Other chapters contain instructions for the daily operator.

Any modifications of the machine must be approved by SHINI in order to avoid personal injury and damage to machine. We shall not be liable for any damage caused by unauthorized change of the machine.

Our company provides after-sales service. Should you have any problem during using the machine, please contact the company or the local vendor.

Shini Hotline Service:

Headquarter and Taipei factory:

Tel: + 886 (0)2 2680 9119

Shini Plastics Technologies (Dongguan), Inc.:

Tel: +86 (0)769 8331 3588

Shini Plastics Technologies (Pinghu), Inc.:

Tel: +86 (0)573 8522 5288

Shinden Precision Machinery (Chongqing), Inc.:

+86 (0)23 6431 0898

## 1.3 Technical Specifications

### 1.3.1 External Dimension

SMH

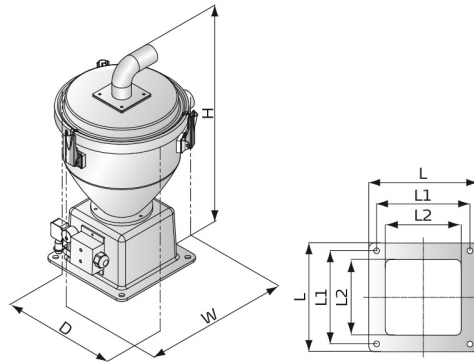

Picture 1-2: SMH External Dimension

Table 1-1: SMH Specification

Model	L(mm)	L1(mm)	L2(mm)
SMH-6L	210	180	148

SVH

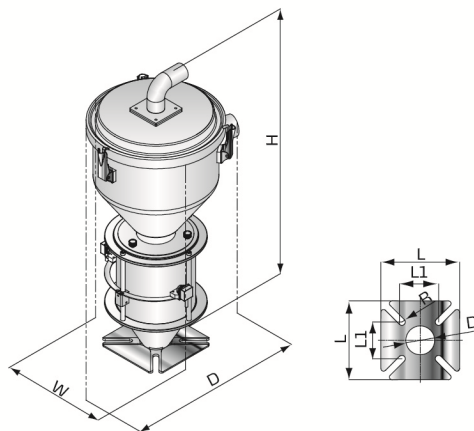

Picture 1-3: SVH External Dimension

Table 1-2: SVH Specification

Models	L(mm)	L1(mm)	D(mm)	R(mm)
SVH-6L	150	70	55	6.5
SVH-12L	180	80	55	6.5

SHR

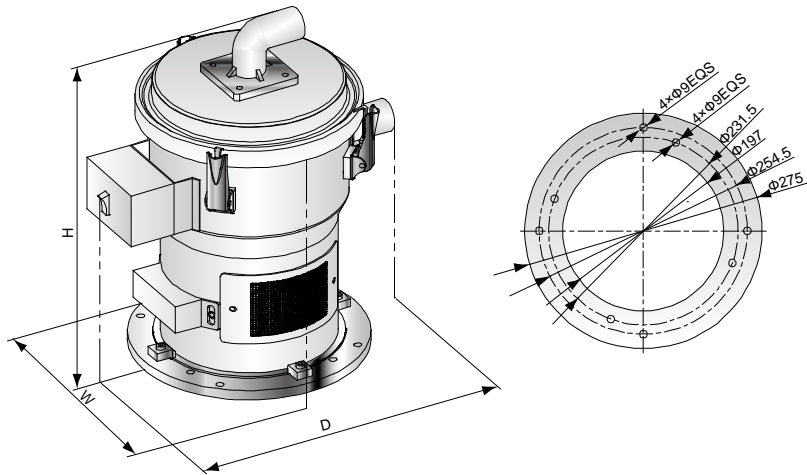

Picture 1-4: SHR External Dimension



## SAL-700G (Main controller)

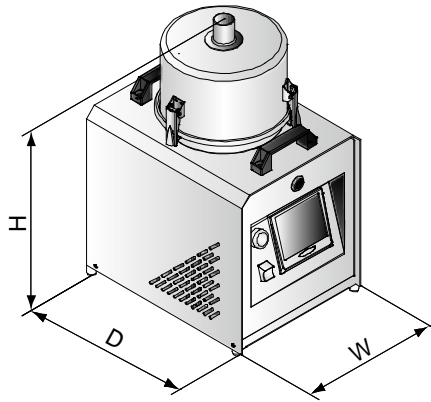

Picture 1-5: SAL-700G External Dimension

### 1.3.2 Specification

Table 1-3: Specification

Model	Ver.	Main Unit				Hopper Receiver(s)				RS-485 communication function	Conveying Hose Dia. (Inch)	Air Suction Pipe Dia. (Inch)	Conveying Capacity (kg / hr)
		Motor Type	Motor Power (kW) (50/60Hz)	Dimensions (mm)H×W×D	Weight (kg)	Recommended Model	Hopper Capacity (L)	Dimensions (mm) H×W×D	Weight (kg)				
SAL-700G	E	Carbon brush	1.2(1Φ)	595×300×410	18	SHR-6U	6	420×285×360	6	•	1.5	1.5	350
						SMH-6L		460×260×315					
						SVH-6L		600×285×305	7				

Notes: 1) "SVH" stands for photosensor hopper receiver; "SMH" stands for vacuum hopper receiver. "SHR-U" stands for Euro-Hopper receiver.

2) Test condition of conveying capacity: Plastic material of bulk density 0.65kg/L, dia. 3~5 mm, vertical conveying height: 4m, horizontal conveying distance: 5m.

3) "•" stands for standard, "○" stands for options, "-" stands for none.

4) Adopt the 4P heavy-duty connector.

5) Power supply: 1Φ, 115/230V, 50/60Hz.

### 1.3.3 Loading Capacity

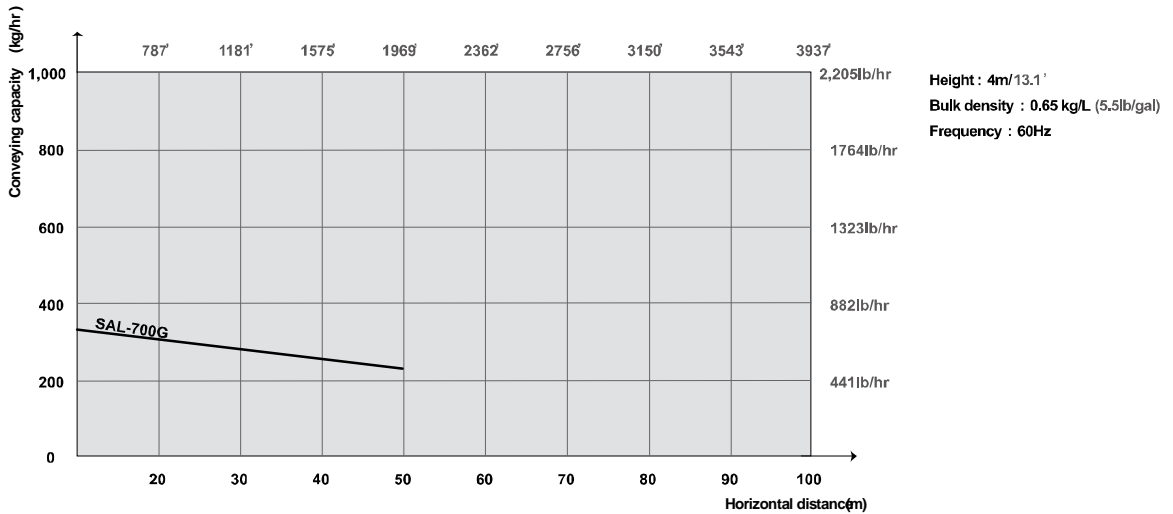

Picture 1-6: Loading Capacity

## 1.4 Safety Regulations

Please abide by the safety guide when you operate the machine so as to prevent damage of the machine and personal injuries.

### 1.4.1 Safety Signs and Labels



All electrical components should be installed by qualified electricians.  
Turn off main switch and control switch during repair and maintenance.



Warning! High voltage!  
This mark is attached on the cover of the control box.



Warning! Be careful!  
Be more careful when this mark appears.



Attention!  
No need for regular inspection because all the electrical parts in the control unit are fixed tightly!

## 2. Structure Characteristics and Working Principle

### 2.1 Working Principle

SAL-700G series are suitable for conveying plastic granules over long distance. Utilizing high efficiency vacuum blower to produce vacuum in material hopper, plastic materials will then be fed into material hopper by air pressure.

#### 2.1.1 SAL-700G Working Principle

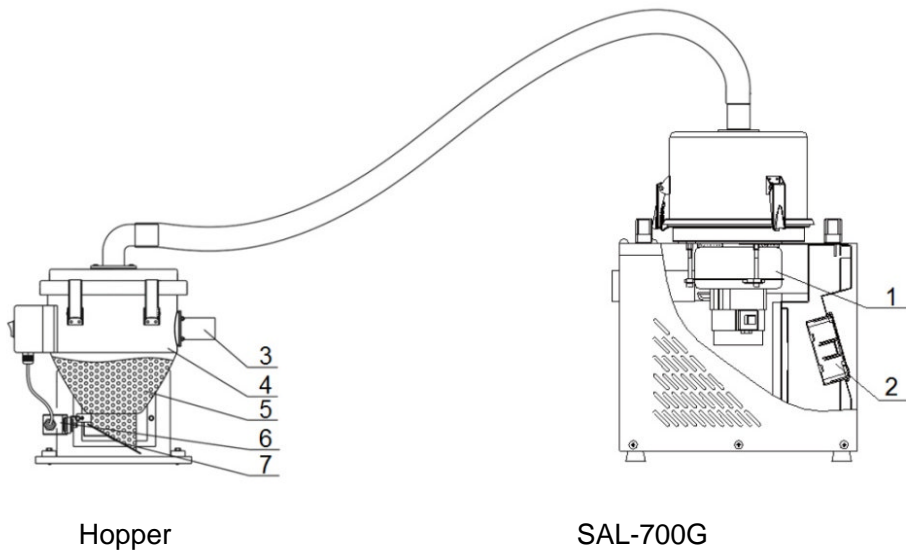

Picture 2-1: Working Principle

- |                         |                     |
|-------------------------|---------------------|
| 1. High-pressure blower | 2. Control box      |
| 3. Material inlet pipe  | 4. Storage hopper   |
| 5. Materials            | 6. Detection device |
| 7. Discharging plate    |                     |

Turn on the machine, the high pressure blower(1)starts work, it makes storage hopper (4) generate the vacuum. Discharging plate(7) closed, materials in silo get into the storage hopper(3) through material inlet pipe(4) by air pressure. When the loader finishes the work, high pressure blower(1) stop working, materials (5) will drop off due to gravity. When the reed switch (7) detects there's no material, high pressure blower (1) will start working again. When the loader can't suck the material or material shortage, the buzzer on control box(2) will alarm.

Table 2-1: Description of detection device

Hopper	Detection device
SHR-U	Reed switch
SMH	microswitch
SVH	photosensor

## 2.2 Accessory

- Cyclone dust collector

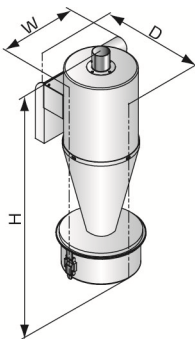

It is suggested to opt cyclone dust collector to reduce cleaning times of filter when regrind material occupies over 30% of total raw material.

Table 2-2: ACF Specification

Model	Capacity (H×W×D)	Pipe diameter (inch)
ACF-1	550×220×235	1.5

- For SHR,SCH-6U/12U/24U and SICH-6U/12U/24U are optional (Temperature reduction is below 30°C within 30min).
- SMH can be matched with SCH-12U/24U to facilitate the temporary storage of materials.

## 2.3 Options

- For polished hopper inside ones,add “P” at the end of the model code.

### 3. Installation Layout

#### 3.1 Installation and Positioning

- 1) Machine just can be mounted in vertical position. Make sure there's no pipe, fixed structure or other objects above the installing location and around the machine which may block machine's installation, hit objects or injure human person.
- 2) For easy maintenance, it's suggested to leave 1m space around the machine.
- 3) Machine should be placed on water-level surface. If it needs to be mounted on a higher surface (e.g. the scaffold or the interlayer), should ensure its structure and size could bear the weight and size of the machine.

#### 3.2 Power Connection

- 1) Make sure the voltage and frequency of the power source comply with those indicated on the manufacturer nameplate that attached to the machine.
- 2) Power cable and earth connection should conform to your local regulations.
- 3) Use independent electrical wires and power switch. Diameter of electrical wire should not be less than those used in the control box.
- 4) The power cable connection terminals should be tightened securely.
- 5) The machine requires 1-phase 2-wire power source, connect the power lead (L, N) to the live wires, and the earth (PE) to the ground.
- 6) Power supply requirements:  
Main power voltage: +/- 5%  
  
Main power frequency: +/- 2%
- 7) ***Please refer to electrical drawing of each model to get the detailed power supply specifications***

#### 3.3 Air inlet/outlet



Picture 3-1: Air inlet / outlet

### 3.4 Installation steps of matching hopper

- 1) Place the SAL-700G machine at a proper position on the ground.
- 2) Install the material hopper on the top of the hopper dryer and the sensor hopper onto the plastic injection machine. Connect the signal cord to the machine SAL-700G.
- 3) Use the steel wire soft hose, connect the air inlets of the sensor hopper to the current air inlets of SAL-700G, then connect the material inlets of storage tank to the vacuum hopper(Usually under the dryer or storage barrel)

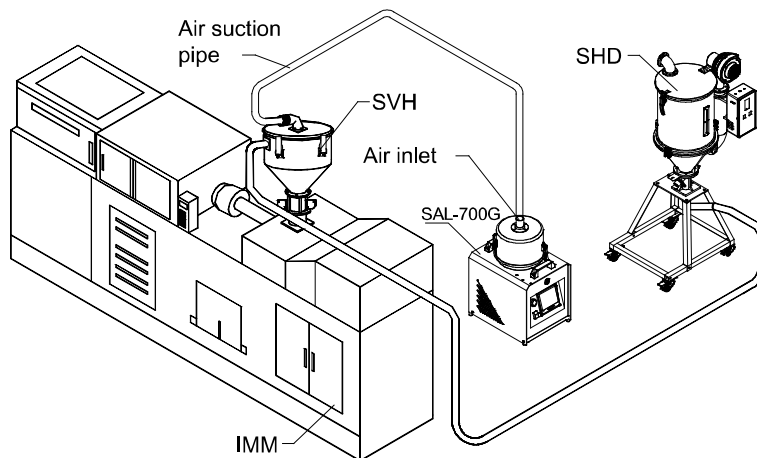

Picture 3-2: Use with SVH

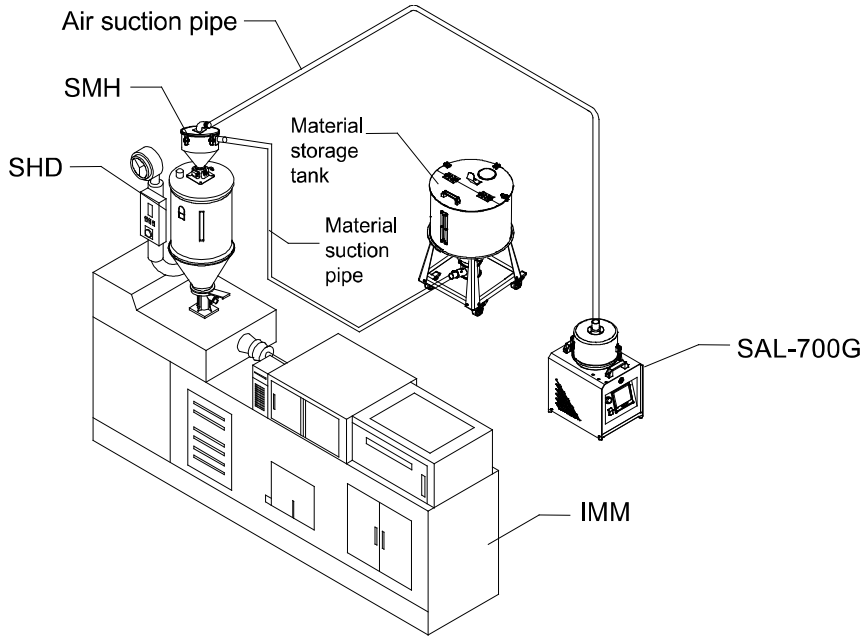

Picture 3-3: Use with SMH

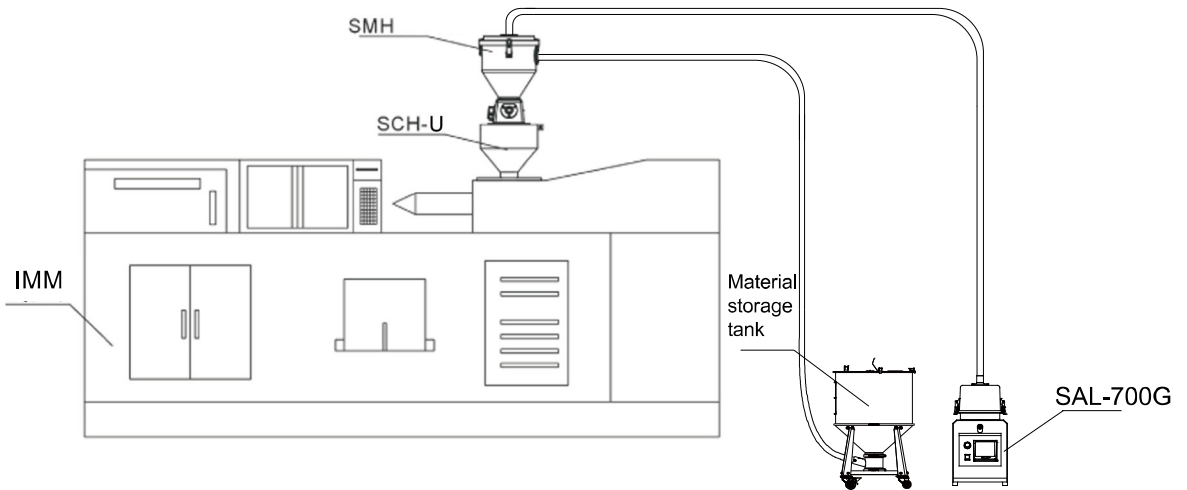

Picture 3-4: Use with SMH and SCH-U

### 3.5 Installation of SAL-G Optional Cyclone Dust Separator

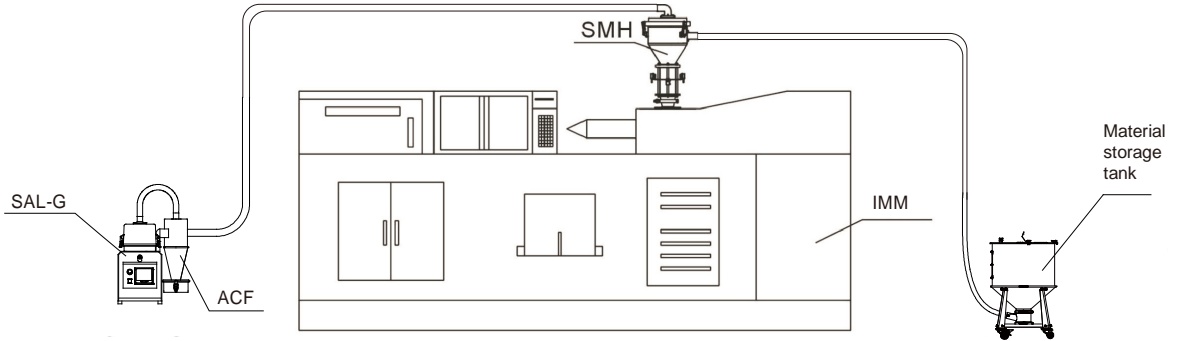

Picture 3-5: Optional ACF-1 Installation Layout

When conveying plastics contain dusts in high proportion, optional dust cyclone separator is recommended to reduce the purging times of main machine filter.

Installation:

- 1) Locate the mounting hole as shown in Figure 3-6;
- 2) Remove the bolt;
- 3) Mount the ACF-1 on coverplate of SAL-G and lock up the screws;
- 4) Connect the air inlet of ACF-1 with steel wire hose to air inlet of the hopper;
- 5) Connect one end of steel wire hose to hopper material inlet, and connect to the suction inlet of storage tank.

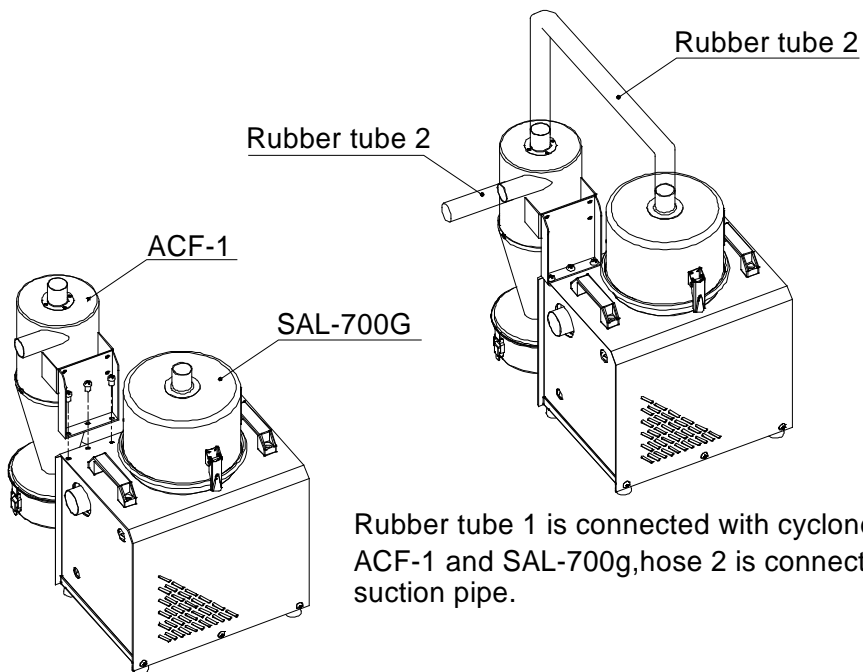

Rubber tube 1 is connected with cyclone dust collector ACF-1 and SAL-700g, hose 2 is connected to hopper air suction pipe.



Picture 3-6: ACF-1 Installation hole position





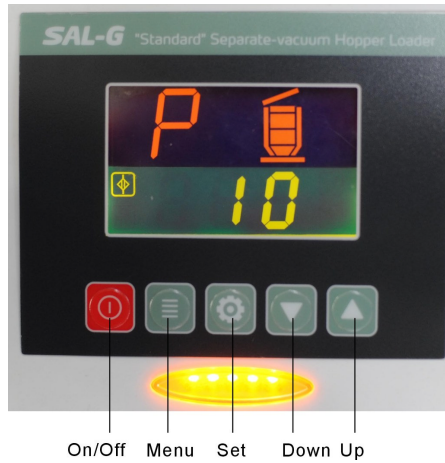

## 4. Operation

### 4.1 Panel Description

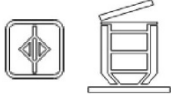

Picture 4-1: Panel

Table 4-1: Panel Description

NO.	Graphical	Name	Meaning	Explain
1		FULL MAT.LIGHT	FULL MAT. LIGHT	It means hopper full of materials
2		BLENDING	MIXING	It means the machine is mixing the materials
3		SHORTAGE ALARM	FULL MAT. ALARM	This alarm means the machine sucked no materials
4		COMMUNICATIO N	COMMUNICA TION	It means the communication is connected through
5		FILTER MESH CLEAN	FILTER CLEANING	It means the filter auto cleaning function
6		OVERLOAD ALARM	OVERLOAD ALARM	It means motor overload

## 4.2 Parameter Setting

- 1) Press Menu key, and enter parameter setting.
- 2) Step 1, Press “Up” and “Down” to select parameter of F1~F8, press “Set” to enter setting
- 3) Step 2, press “Up” and “Down” to adjust the parameters, press “Set” for confirmation and return to up page.

Table 4-2: Symbol status description

Code	Status	Default Value	Adjusting Range
F1	Suction time setting	10 Secs.	1~99 Secs.
F2	Necessary spray washing times every several times for operation	3 Times	1~10 Times
F3	Necessary cleaing times for reverse running every several times of operation	3 Times	1~10 Times
F4	Motor reverse running time	10 Secs.	5~30 Secs.
F5	Alarm detecting time	20 Secs.	10~40 Secs.
F6	Awaits motor to stop time	30 Secs.	30~99 Secs.
F7	Purge times	2 Times	1~5 Times
F8	Suction awaits time	0	0~99 Times
F9	Communication baud rate	1(9600)	0—19200, 1—9600,2=4800
F10	Communication address	1	1~99
F11	Odd-even verification	0	0— no verification 1— odd verification 2— even verification

Table 4-3: Communication Address (Protocol Modbus-RTU)

Address (Keep the deposit area) (decimal system)	Parameters	Reading R/Writing W	Default Parameters	Minimum Value	Maximum Value	Unit
0x00	bit 0 shutdown	R	0 startup	/	1 in shutdown	/
	bit 1 standby				1 in standby	
	bit 2 suction				1 in suction	
	bit 3 Detected shortage time after suction				1 in detecting	
	bit 4 Reverse spraying				1 in spraying	
	bit 5 Reverse replying time				1 in calculating	
	bit 6 Overload alarm				1 in alarming	
	bit 7 Shortage alarm				1 in alarming	
	bit8~bit16Undefined					
0x01	Real-time information	R	/	/	/	/
0x02	Running mode	R/W	1	1	4	/
0x03	Suction time	R/W	5	10	99	S
0x04	Working times before each cleaning	R/W	1	3	10	times
0x05	Working times before each reverse running	R/W	1	3	10	times
0x06	Reverse running time	R/W	5	10	30	s
0x07	The time before giving alarm when the machine is short of materials after suction	R/W	10	20	40	s
0x08	Reverse replying time	R/W	30	30	99	S

0x09	The times of C2 cleaning	R/W	1	2	5	times
0x0a	Suction waiting time	R/W	0	0	99	Mins.
0x0b	0x02 already running times	R	/	/	/	times
0x0c	0x03 already running times	R	/	/	/	times
0x0d	bit 0 shortage input signal	R	0 full mat.	/	1 short of materials	/
	bit 1 overload input signal		0 no overload		1 overload	
	bit 2, bit3 reserved					
	bit 4 suction output		0 no output		1 ouput	
	bit 5 spraying output		0 no output		1 ouput	
	bit 6 alarm output		0 no output		1 ouput	
	bit7~bit16 undefined					
0x0e	bit 0 shutdown	R	0 startup	/	1 in shudown	/
	bit 1 standy				1 in standby	
	bit 2 suction				1 in suction	
	bit 3 detected shortage time after suction				1 detecting	
	bit 4 reverse spraying				1 spraying	
	bit 5 reverse replying time				1 calculating	
	bit 6 overload alarm				1 alarming	
	bit 7 shortage alarm				1 alarming	
	bit7~bit16 undefined					
0x0f	On/Off signal	W	0 startup	/	1 shudown	/

## 5. Troubleshooting

Fault	Possible reasons	Solutions
When shortage lasts long, and suction blower don't run.	The main switch and control switch don't open or the above two don't connect well.	Close the main switch and control switch and check their connecting.
	The microswitch on hopper don't connect well .	Adjust or replace.
	The signal wire is break off.	Re-connect.
The suction blower still running when the hopper is full.	The touch point is conglutinated	Repair or replace.
After several times of loading the material hopper still empty or the material shortage alarms.	The storage tank is empty.	Add the material
	The pipe is air leak.	Lock tightly and replace the vacuuming pipe.
	The filter is blocked.	Clean the filter.
The motor can't run.	Short-phase or motor was burnt out.	Check and replace.
The fuse always burnt out after start-up.	Short circuit or connect the ground.	Check the circuit.
Motor overload alarms	The filter is blocked.	Clean the filter and reset the overload relay.
	One of three phase is lacking.	Check the circuit and reset the overload relay.kkk
Poor material liquidityin the pipe	Over or lack of air quantity	Adjust air inlet location of the suction box. Avoid small bending of the elbow.

## 6. Maintenance

### 6.1 Hopper Cleaning (Take SVH as an example)

SMH Cleaning: In order to avoid air-blocking and to get smooth conveying.

Clean the filter screen inside of material hopper. Unlock the snap hook on the hopper, remove the hopper cover and take out the filter screen, then clean it. Clean the filter periodically or when the suction force is reduced.

SVH Cleaning:

1. Clean the filter screen, in order to avoid air-blocking and to get smooth conveying. Clean the filter screen inside of material hopper. Unlock the snap hook on the hopper, remove the cover and take out the filter, then clean it. Clean periodically or when the suction force is reduced.
2. Clean the glass pipe, when the dust accreted on the tube. Clean the dust in time for machine normal working.

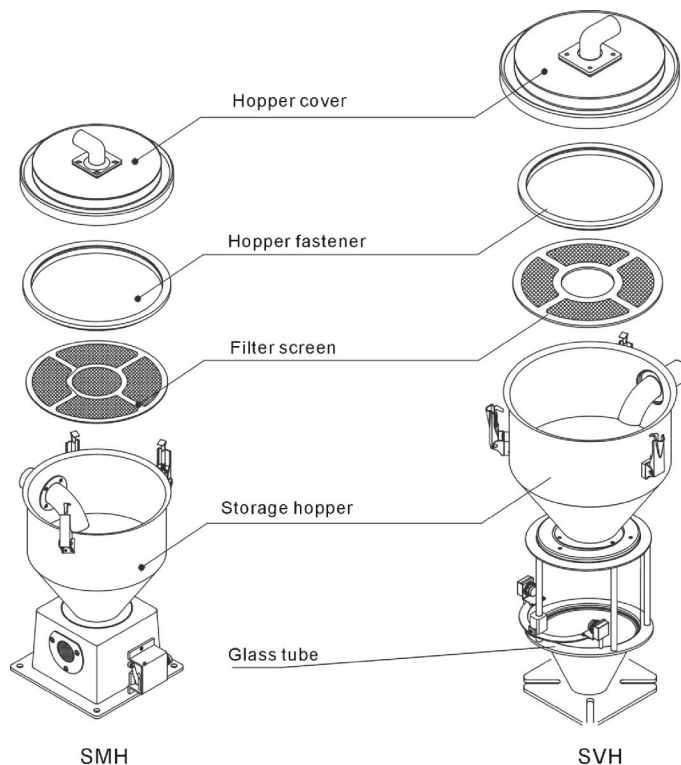

Picture 6-1: Hopper Cleaning



## 6.2 Main Body Cleaning

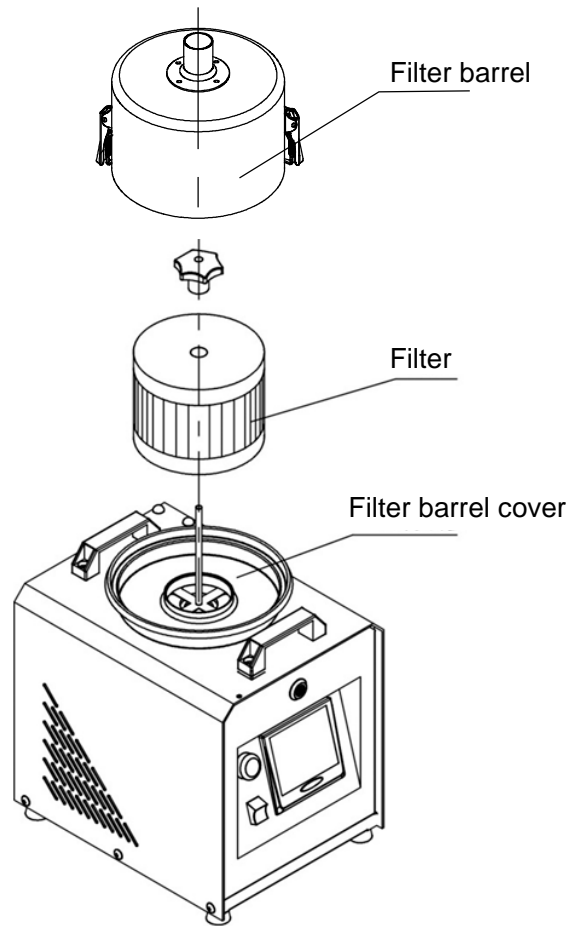

Picture 6-2: Host Unit Cleaning

When machine in use, clean the filter periodically or when the suction force is reduced. Take out the filter from the main body, clean the dust accreted on it to ensure good ventilation of the air and to enhance loading capacity.

### Filter Inspection and Storage Hopper Cleaning

1. Loosen the snap hook, take out the filter barrel and the filter; blow off the dust with a high-pressure air gun from the inside to outside; take down the filter barrel cover and remove the dust in it.
2. Clean the filter. Period: daily