

# **SAL-UG**

## **Separate-vacuum Hopper Loader**

Date: Apr., 2023

Version: Ver.D (English)





## Contents

<b>1. General Description .....</b>	<b>5</b>
1.1 Coding Principle.....	6
1.2 Feature .....	6
1.3 Loading capacity.....	8
1.4 Safety Regulations.....	8
1.4.1 Safety Signs and Labels.....	8
1.4.2 Signs and Labels.....	9
1.5 Exemption Clause.....	9
<b>2. Structure Characteristics and Working Principle.....</b>	<b>10</b>
2.1 Main Functions.....	10
2.1.1 Working Principle .....	10
<b>3. Installation and Debugging .....</b>	<b>12</b>
3.1 Install the Machine on the Dryer .....	12
3.1.1 Installation Elements .....	12
3.1.2 Installation Steps.....	12
3.1.3 Power Supply .....	13
<b>4. Application and Operation.....</b>	<b>14</b>
4.1 Control panel description .....	14
4.2 Parameter Setting .....	15
4.2.1 Parameter Setting .....	15
4.2.2 Communication Parameter Setting.....	18
4.3 Alarm Program.....	18
4.4 Operaton Procedure Description.....	19
4.4.1 Operation Procedure .....	19
4.4.2 Data Resetting.....	20
4.5 Communication Address (protocol modbus-RTU) .....	21
<b>5. Trouble-shooting.....</b>	<b>25</b>
<b>6. Maintenance and Repair .....</b>	<b>26</b>
6.1 Material Hopper .....	26

6.2 Main Body .....	27
6.3 Glass Tube .....	27
6.4 Reed Switch, Photoelectric Switch.....	28
6.5 Weekly Checking .....	28
6.6 Monthly Checking .....	28
6.7 Maintenance Schedule .....	29
6.7.1 About the Machine .....	29
6.7.2 Installation & Inspection .....	29
6.7.3 Daily Checking .....	29
6.7.4 Weekly Checking.....	29
6.7.5 Monthly Checking.....	29

### Picture Index

Picture 1-1: SAL-20HP-UG.....	5
Picture 1-2: Loading Capacity .....	8
Picture 2-1: Working Principle .....	10
Picture 3-1: Installation Elements .....	12

## 1. General Description



Read this manual carefully before operation to prevent damage of the machine or personal injuries.

SAL-UG series separate-vacuum hopper loader are based on the established design and now feature more attractive appearance, better performance, and improved ease of operation. The whole range comprises of seven models equipped with vacuum blower from 1 to 15 HP. Economy models can be offered on request.



Picture 1-1: SAL-20HP-UG

## 1.1 Coding Principle

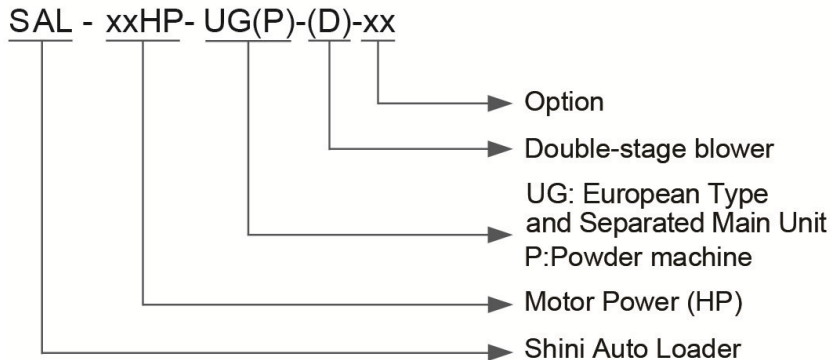

## 1.2 Feature

- The series of SAL-UG/UGP modes adopt LCD displayer + microcomputer controller which features direct display and easy operation;
- The controller has independent mixing and shut-off output function, which can control the proportional valve SPV-U and shut-off box SBU directly;
- Equipped with RS485 communication interface;
- Equipped with audible and visual alarm
- SAL-5HP-UG and above models are equipped with standard filter purging devices;
- SAL-5HP-UG/UGP(-D) series integrates cyclone and filter that effectively reduces the filter load;
- The series of SAL-UG/UGP models are equipped with vacuum breaking valve to protect the protector;
- SAL-UG series is equipped with Euro stainless steel hopper to ensure no materials contamination.

All service work should be carried out by a person with technical training or corresponding professional experience. The manual contains instructions for both handling and servicing. Chapter 6, which contains service instructions intended for service engineers. Other chapters contain instructions for the daily operator.

Any modifications of the machine must be approved by SHINI in order to avoid personal injury and damage to machine. We shall not be liable for any damage caused by unauthorized change of the machine.

Our company provides excellent after-sales service. Should you have any problem during using the machine, please contact the company or the local vendor.

Shini Hotline Service:

Headquarter and Taipei factory:

Tel: + 886 (0)2 2680 9119

Shini Plastics Technologies (Dongguan), Inc.:

Tel: +86 (0)769 8331 3588

Shini Plastics Technologies (Pinghu), Inc.:

Tel: +86 (0)573 8522 5288

Shinden Precision Machinery (Chongqing), Inc.:

+86 (0)23 6431 0898

### 1.3 Loading capacity

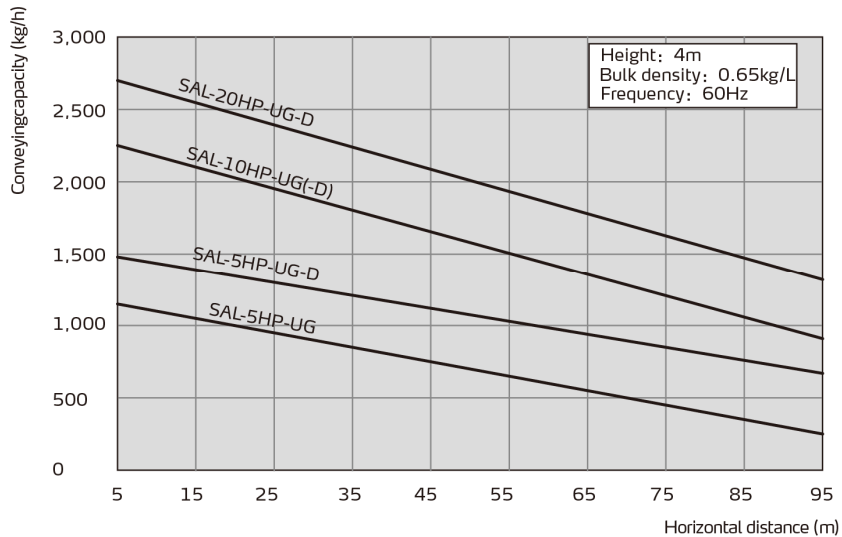

Picture 1-2: Loading Capacity

### 1.4 Safety Regulations

Strictly abide by the following safety regulations to prevent damage of the machine or personal injuries.

#### 1.4.1 Safety Signs and Labels



All the electrical components should be installed by professional technicians.

Turn off the main switch and control switch during maintenance or repair.



Warning! High voltage!

This sign is attached on the cover of control box!



Warning! Be careful!

Be more careful at the place where this sign appears!



Attention!

No need for regular inspection because all the electrical parts in the control unit are fixed tightly!



## 1.4.2 Signs and Labels

	<ol style="list-style-type: none"><li>1. Please clean the suction filter regularly to avoid clogging and ensure proper loading capacity and long life span.</li><li>2. The one year warranty does not cover the suction filter, please clean the filter carefully.</li></ol>
---	--

## 1.5 Exemption Clause

The following statements clarify the responsibilities and regulations born by any buyer or user who purchases products and accessories from Shini (including employees and agents).

Shini is exempted from liability for any costs, fees, claims and losses caused by reasons below:

1. Any careless or man-made installations, operation and maintenances upon machines without referring to the Manual prior to machine using.
2. Any incidents beyond human reasonable controls, which include man-made vicious or deliberate damages or abnormal power, and machine faults caused by irresistible natural disasters including fire, flood, storm and earthquake.
3. Any operational actions that are not authorized by Shini upon machine, including adding or replacing accessories, dismantling, delivering or repairing.
4. Employing consumables or oil media that are not appointed by Shini.

## 2. Structure Characteristics and Working Principle

### 2.1 Main Functions

SAL-UG series "Euro" Separate-vacuum hopper Loaders are suitable for conveying plastic granules over long distance. Utilizing high efficiency vacuum blower to produce vacuum in material hopper, plastic materials will then be fed into material hopper by outside pressure.

#### 2.1.1 Working Principle

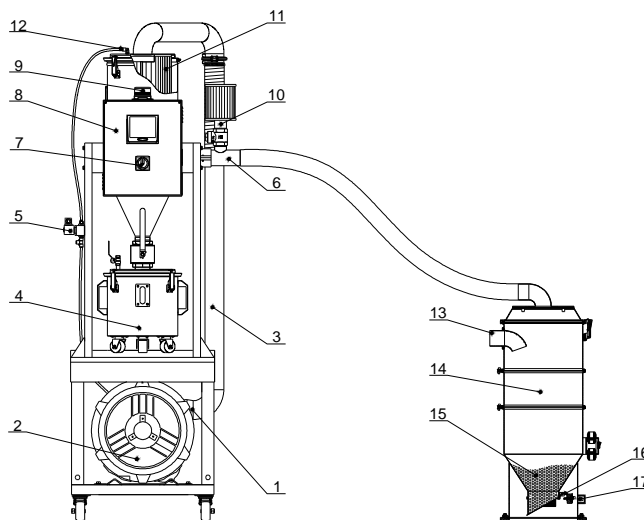

#### Parts Name:

- |                              |                             |                                     |                           |
|------------------------------|-----------------------------|-------------------------------------|---------------------------|
| 1. Vacuum breaking separator | 2. Blower                   | 3. Vacuum breaking separating valve | 4. Dust collective hopper |
| 5. Spraying solenoid valve   | 6. suction port             | 7. Main power switch                | 8. Control box            |
| 9. Alarm light               | 10. Reverse spraying filter | 11. Filter                          | 12. Spraying device       |
| 13. Mat. inlet pipe          | 14. Hopper                  | 15. Material                        | 16. Discharge plate       |
| 17. Reed switch              |                             |                                     |                           |

Picture 2-1: Working Principle

After the main power switch (7) is turned to the right, and the control box (8) is powered on, the blower (2) starts working, causing negative pressure vacuum to be generated in the hopper (14). Meanwhile, the discharge plate (16) is closed, and the materials (15) in the material storage tank enter the hopper due to the air pressure difference from the feeding pipe (13). After the suction time is over, the

blower (2) stops running, and the materials (15) will fall due to their own weight. When the magnetic reed switch (17) detects that there is no material, the blower (2) will start again. When the material can't be sucked for three times, the control box (8) will judge that the hopper (14) is short of material, and the alarm light (9) on the electric control box (8) will light up to alert.

During the blower (2)'s running, the airflow in the suction port (6) through the filter barrel cyclone device to enter the filter (11) to filtrate the dust and the dust adhering on the surface of the filter (11). After the blower (2)'s suction, the control box (8) will send a spraying signal to the spraying solenoid valve (10) to start work. Then, the high pressure air will directly spray a large amount of compressed gas into the spraying device (12), thus generating an outward impact airflow on the filter (11). The air will be discharged into the reverse spraying filter (10) and to the outside through the suction port, enabling the filter (11) to remove the dust adhering on the surface into the dust collective hopper (4).

### 3. Installation and Debugging

This series of models only could be applied in working environment with good ventilation.



Read this chapter carefully before installation of the machine. Install the machine by following steps.

Power supply should be fixed by qualified technicians!

#### 3.1 Install the Machine on the Dryer

##### 3.1.1 Installation Elements

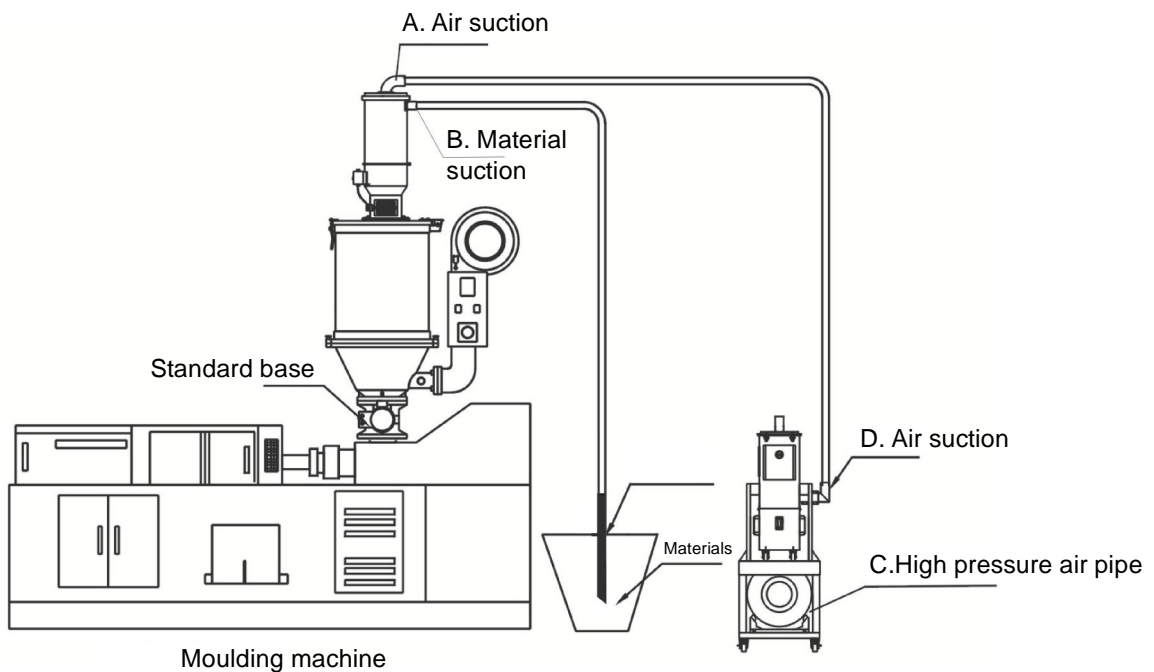

Picture 3-1: Installation Elements

##### 3.1.2 Installation Steps

- 1) Put the main body of the machine at a proper place and connect it with power supply.
- 2) Install material hopper onto the dryer and connect it with signal wires from the main body.
- 3) Use steel wire conveying hose to connect air suction pipe (A) on material

hopper with air suction pipe (D) on main body. Material suction (B) should be connected with material suction probe (B) in material storage bin.

4) Connect high pressure air pipe (C) with air supply (pressure at 3~6kg/cm<sup>2</sup>).

### 3.1.3 Power Supply

Make sure that the power supply conforms to required specifications before installation. SAL-UG (E) Series should be connected with 3Φ 400V 50Hz Power supply or other specifications if required.





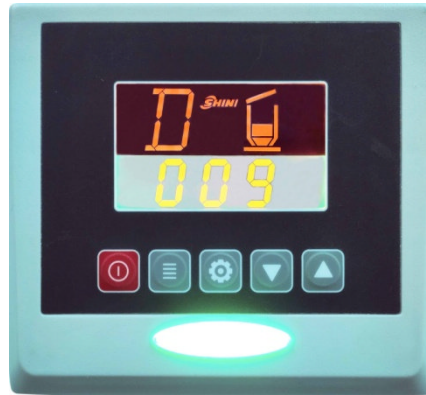

***Note: Make sure main switch is turned off before you connect the power.***



## 4. Application and Operation

### 4.1 Control panel description

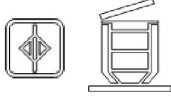

Pic.4-1: Description of operation panel keys

NO.	Symbol	Name	Description
1		ON/OFF	Start/stop the machine
2		MENU	Enter or exit parameter setting
3		SET	Modify or confirm machine parameters
4		DOWN	Move the menus down, and reduce the value
5		UP	Move the menus up, and increase the value
6		FULL MAT.LIGHT	It means full materials in the hopper
7		BLENDING	It means the machine is mixing the materials in the hopper
8		MAT.SHUT-OFF	It means the machine is shutting off the materials

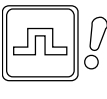
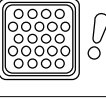
9		SHORTAGE ALARM	It means machine alarm for no materials during suction
10		COMMUNICATION	It means the communication is connecting through
11		FILTER MESH CLEAN	It means filter auto cleaning function
12		OVERLOAD ALARM	It means motor overload error
13		SCREEN BLOCKING	Prompt to clean or replace the filter screen

## 4.2 Parameter Setting

In OFF mode, Press <MENU>, and enter parameter setting.

Press <DOWN> or <UP> to select parameter, press <SET> enter setting.

Press <DOWN> or <UP> modify parameters, press <SET> Confirm revision.

### 4.2.1 Parameter Setting

Code	Status	Parameters	
		Preset value	Range
F.01	<p>Suction action time</p> <p>Motor suction time when there's a shortage of materials, which is also the vacuum breaking valve's working time.</p> <p>Corresponding action: <b>D</b></p>	15 secs.	5-127 secs.
F.02	<p>Shut-off action time</p> <p>Start with the suction action at the same time, and set the shut-off time. Set 0 as not start.</p>	0	0-100 secs.

F.03	<p style="text-align: center;">Mixing proportion</p> <p>Start at the same time with the suction action, and set the mixing proportion. Time calculation method: suction time * [F.03]% Set 0 as not start.</p>	<p style="text-align: center;">0% Not start</p>	<p style="text-align: center;">0-100%</p>
F.04	<p style="text-align: center;">Mixing mode</p> <p>The number of layers of mixing action when it starts mixing. For example: the suction time is 20sec, the mixing proportion is 10%, the number of layers is 2, and then the mixing action is 9s—1s ----9s---1s Set single layer's working, and the suction time range is 5-99 secs. Set double layers' working, and the suction time range is 17-99 secs. Set three layers' working, and the suction time range is 32-99 secs. Set four layers' working, and the suction time range is 46-99 secs. If the suction time changes, the min. action time is less than 1 sec. after calculation, and the program will force to change the action time to 1 sec.</p>	<p style="text-align: center;">1</p>	<p style="text-align: center;">1-4times</p>
F.05	<p>Mixing action            count cycle start setting</p> <p>Count from the first start-up, and start once mixing action after several times of repeated suction startings. Set 1 as mixing materials every time. Set [F.03] to 0 without mixing.</p>	<p style="text-align: center;">once</p>	<p style="text-align: center;">1-9 times</p>
F.06	<p style="text-align: center;">Setting time of cleaning before suction</p> <p>Set 0 as the no screen cleaning before suction. Corresponding action: R01</p>	<p style="text-align: center;">0 secs.</p>	<p style="text-align: center;">0-99 secs.</p>
F.07	<p style="text-align: center;">Setting time of screen cleaning after suction</p> <p>Set 0 as no screen cleaning after suction. Corresponding action: R11</p>	<p style="text-align: center;">5 secs.</p>	<p style="text-align: center;">0-99 secs.</p>
F.08	<p style="text-align: center;">Screen cleaning cycle</p> <p>It starts once [F.06] or [F.07] cleaning action only after several times of repeated suction actions. Set 1 as cleaning the screen cleaning at every suction.</p>	<p style="text-align: center;">10 times</p>	<p style="text-align: center;">1-99 times</p>
F.09	<p style="text-align: center;">Circulating suction waiting time</p> <p>Waiting time before a new suction action starts after each suction action. Set 0 as not waiting. Waiting time before a new suction action starts Corresponding action: N03</p>	<p style="text-align: center;">0 (Unit 10 secs.)</p>	<p style="text-align: center;">0-9990</p>



F.10	<p style="text-align: center;">Shortage metering alarm</p> <p>Set the number of times that the material doesn't fall into the hopper, and it should alarm after several times of this error occurs.</p> <p>Alarm cleaning mode:</p> <ol style="list-style-type: none"> <li>1.The alarm will dismiss when it feeds the materials again.</li> <li>2. Ent key on the panel can be cancelled.</li> <li>3.Turn on the power again.</li> </ol> <p>Set 9 as cancelling this function.</p> <p>Corresponding action: A.01</p>	3	1-9 times
F.11	<p style="text-align: center;">Shutdown alarm for the times of material shortage</p> <p>Set the number of times that no material falling into the hopper. The times of material shortage that it should alarm.</p> <ol style="list-style-type: none"> <li>1.ENT key on the panel can be cancelled.</li> <li>2.Turn on/off the power again.</li> </ol> <p>Corresponding action: A.04</p>	3	[F.10]-99
F.12	<p>The time waiting for motor stoppage (suitable for sal-430 / 460) .</p> <p>After motor starts, it only takes next action after the time countdown is finished.</p>	20 secs.	0-99 secs.
F.13	<p style="text-align: center;">Buzzer alarm type</p> <p>0: Lasting alarm 1: Slow and interrupted alarm 2:Fast and interrupted alarm</p>	0	0-2
F.14	<p style="text-align: center;">Motor delay stop time</p> <p>After [F.01] suction time is ended, the delay time before motor stop.</p>	0 secs.	0~999 secs.
F.15	<p style="text-align: center;">Motor working time</p> <p>Check motor working time and clear the time.</p> <p>The method to clear the motor working time: Set the setting value as 0, and press ENT key to cancel.</p>	0 (unit: 10 hrs.)	0-999 Only 0 means clearing the time.



## 4.2.2 Communication Parameter Setting

Press <MENU> key and < UP > key together for 3 secs. to enter parameter setting screen.

Code	Functional Description	Parameters	
		Preset value	Range
F.30	Comm. address	1	1-99
F.31	Baud rate 0---19200    1---9600    2---4800	1	0-2
F.32	Odd-even check 0---No test    1--- Odd parity    2--- Even parity	0	0-2

## 4.3 Alarm Program

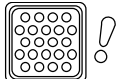
Description of blender controller, alarm status and solution method

Panel Code	Alarm Causes	Solution Method
	<p>Shortage alarm [F.10]</p> <ol style="list-style-type: none"> <li>1. The set suction time is too short.</li> <li>2. The materials can't be absorbed.</li> <li>3. Suction pipeline is blocked.</li> <li>4. Pipeline suction is too small.</li> </ol>	<ol style="list-style-type: none"> <li>1) Add materials</li> <li>2) Increase suction time</li> <li>3) Shut down and check the pipe line.</li> </ol> <p>When it sucks the materials again, the alarm will dismiss or the ENT key on the panel can also be cancelled or turn on the power again.</p>
	<p>Filter warning Filter screen blocking</p>	<ol style="list-style-type: none"> <li>1) Shut down and clean the filter screen or replace filter screen.</li> </ol> <p>The alarm will dismiss when it turns on/off the power again or it can be cancelled by clicking the ENT key on the panel.</p>
	<p>Motor overload alarm</p> <p>When an overload alarm occurs, it alarms for shutdown.</p>	<ol style="list-style-type: none"> <li>1) If the motor is damaged, replace the motor.</li> <li>2) The setting of thermal overload is wrong, adjust the setting value again.</li> </ol> <p>Check the cause of motor overload and turn on the power again;</p>

## 4.4 Operaton Procedure Description

### 4.4.1 Operation Procedure

Panel Code	Action Description	Corresponding Parameter	Parameters	
			Factory Setting	Range
R01	Filter screen cleaning	F.06	3 secs.	0-99 secs.
R02	Waiting for motor stop	F.12	3 secs.	0-99 secs.
D	Absorbing the materials (vacuum breaking valve action)	F.01	15 secs.	5-127 secs.
	Absorbing masterbatch material (Close the vacuum breaking valve after the action is stopped)	F.03	0%	0-100%
		F.05	3	1-9 次
N01	Waiting time	F.12	3 secs.	0-99 secs.
R11	Cleaning filter screen The materials start to discharge to the hopper	F.07	0 secs.	0-99 secs.
R12	Waiting motor stop	F.12	3 secs.	0-99 secs.
N02	Waiting materials completely discharge to the hopper	F.20	10 secs.	5-99 secs.
N03	Waiting for material circulating suction	F.09	0 secs.	0-9990 secs.
P	Waiting for suction confirmation			

## 4.4.2 Data Resetting

- ① Turn off the machine plate power
- ② Short circuit the two terminals of J2

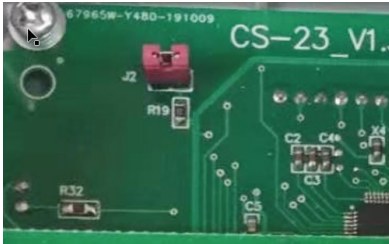

- ③ Turn on the machine plate power
- ③ Remove the short circuit of J2's two terminals after three secs.



- ⑤ Completed

*Notes: All parameter settings will be reset to factory settings. Please use this function carefully.*

## 4.5 Communication Address (protocol modbus-RTU)

Address (keeping deposit zone) (decimal)	Parameters	Reading R/ Writing W	Default Parameter	Min. Value	Max. Value	Unit
0	Current action	R	/			/
	bit 0 shutdown			0	1	
	bit 1 standby			0	1	
	bit 2 absorb materials			0	1	
	bit 3 wait for material discharge			0	1	
	bit 4 cleaning the screen			0	1	
	bit 5 wait for motor stopping			0	1	
	bit 6 screen blocking alarm			0	1	
	bit 7 shortage alarm			0	1	
	Bit 8-bit 16 undefined					
1	Real-time info.	R	/			/
3	Suction action time	R/W	15	5	127	S
4	Screen cleaning action cycle	R/W	10	1	99	次
6	Screen cleaning setting time	R/W		0	99	S
7	Discharge checking time	R/W	10	5	99	S
8	Standby time after motor running	R/W	0	0	99	S
9	Screen cleaning setting time after suction	R/W	5	0	99	S
10	Waiting time for circulating suction	R/W	0	0	9990	10S
13	Input and output status	R	/			/
	bit 0 shortage input signal			0 full mat.	1 mat.	

					shortage	
	bit 1 filter screen blocking input signal			0 no blocking	1 blocking	
	bit 4 suction output			0 no output	1 output	
	bit 5 spraying valve output			0 no output	1 output	
	bit 6 alarm output			0 no output	1 output	
	bit7~bit15 undefined					
14	Current action	R	/			/
	bit 0 shutdown			0	1	
	bit 1 standby			0	1	
	bit 2 absorbing materials			0	1	
	bit 3 waiting for material discharge			0	1	
	bit 4 clean the filter screen			0	1	
	bit 5 wait for motor stop			0	1	
	bit 6 filter blocking alarm			0	1	
	bit 7 shortage alarm			0	1	
	bit8~bit15 undefined					
15	Startup & shutdown control	W	/	0 startup	1 shutdown	/
16	Suction action time	R/W	15	5	127	S
17	Mixing proportion	R/W	0	0	100	%
18	Circulating startup setting of mixing action counting	R/W	1	1	9	times
19	Filter screen action cycle	R/W	3	1	99	times
20	Circulating suction waiting time	R/W	0	0	9990	10S

21	Screen cleaning setting time before suction	R/W	0	0	99	S
22	Screen cleaning setting time after suction	R/W	5	0	99	S
23	Discharge checking time	R/W	10	5	99	S
24	Material shortage counting alarm	R/W	3	1	9	times
25	Material shortage counting stop alarm	R/W	3	Mat. shortage counting alarm	99	times
26	Standby time after motor running	R/W	20	0	99	S
27	Buzzer alarm type	R/W	1	0	2	/
29	Motor working time record	R/W	0	0	999	10h
30	Full mat. detecting time	R/W	3	1	9	S
31	Mat. shortage detecting time	R/W	3	1	9	S
32	Mat. shut-off time	R/W	0	0	100	S
34	Motor delay stop time	R/W	0	0	999	S
35	Accumulating times of mixing actions	R	0	0	0x03 set value	times
36	Accumulating times of screen cleaning actions	R	0	0	0x04 set value	times
37	Accumulating times of material shortage alarm	R	0	0	99	times
38	Startup & shutdown control	W		0 startup	1 shutdown	/
39	Current action	R	/			/
	bit 0 startup			0	1	
	bit 1 standby			0	1	
	bit 2 cleaning the filter screen			0	1	
	bit 3 wait for motor stopping			0	1	
	bit 4 absorb the material			0	1	
	bit 5 absorb the masterbatch material (mixing)			0	1	

	bit 6 wait for material discharge			0	1	
	bit 7 wait for circulating suction			0	1	
	Bit 8 ~bit 15 undefined					
40	real-time information	R	/			/
41	Input and output state	R	/			/
	bit 0 shortage input signal			0 full mat.	1 mat. shortage	
	bit 1 filter blocking input signal			0 no blocking	1 blocking	
	bit 2 suction output			0 no output	1 output	
	bit 3 vacuum breaking output			0 no output	1 output	
	bit 4 mixing output			0 no output	1 output	
	bit 5 spraying valve output			0 no output	1 output	
	bit 6 alarm output			0 no output	1 output	
	bit7~bit15 undefined					
42	alarm state	R	/			/
	bit 0 shortage alarm			0	1	
	bit 1 mat. shortage stop alarm			0	1	
	bit 2 filter blocking alarm			0	1	
	bit 3~bit 15 undefined					
45	The number of mixing layers	R/W	1	1	4	layer
46	Action mode (only can be set in shutdown)	R/W	5	1	5	/

Notes: R means only reading

W means only writing

R/W means writing and reading

**Note: The password is not set in factory, which can be set by users. In case of loss, please contact us.**



## 5. Trouble-shooting

Failures	Possible reasons	Solutions
Motor does not work long after material discharge.	1. Main power switch or control switch is off or poorly connected.	1. Turn on main switch and control switch and make sure they are well connected.
	2. Poor contact of magnetic proximity switch.	2. Adjust or replace.
	3. Signal wire is broken.	3. Reconnect
Motor keeps on working after material hopper is full-loaded.	Contactor malfunction.	Repair or replace contactor
Motor can not fully load material hopper, or machine sounds material shortage alarm.	1. No materials left for conveying.	1. Adding material.
	2. Air pipe breakage.	2. Firmly lock it or replace.
	3. Cloth filter is blocked.	3. Clean cloth filter.
Motor can not work.	Phase shortage or motor is burt out.	Check or replace.
Fuse melts each time you turn on the machine.	Short circuit or motor is burt out.	Check electrical circuit.
Motor overload alarm	1. Filter screen is blocked.	Clean the filter screen and press Reset on the overload relay.
	2. Phase shortage	Check the electrical circuit and press Reset on the overload relay.
Poor material liquidityin the pipe	Over or lack of air quantity	Adjust air inlet location of the suction box. Avoid small bending of the elbow.

## 6. Maintenance and Repair

**Note: All the repair work should be done by professionals in order to prevent personal injuries and damage of the machine.**

### Main body, Filter Inspection and Storage Hopper Cleanup

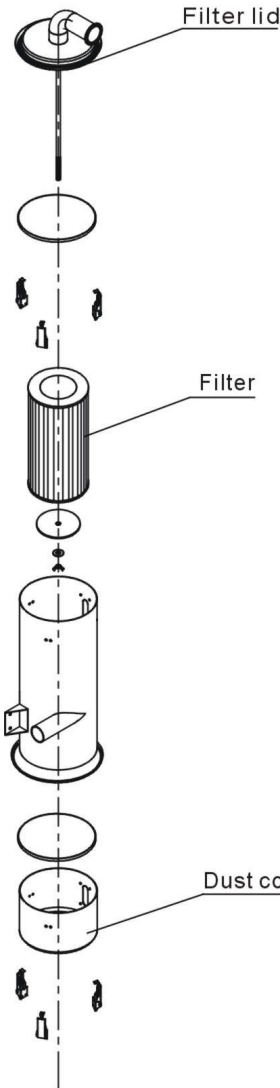

1. Remove the spraying air pipe first, open the filter barrel cover, take out the filter, and use a high-pressure air gun to blow the dust off the filter from inside to outside.
2. Clean the filter.  
Period: daily
3. Clean the dust collection bin.  
Period: daily

### Hopper, Screener

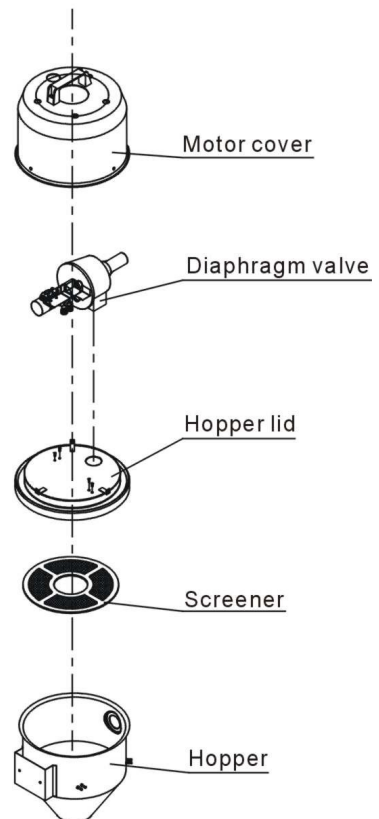

1. Loosen the snap hook on the hopper, remove the hopper lid, take out the screener and eliminate the dust on it.
2. Clean the Screener.  
Period: daily

### 6.1 Material Hopper

Clean material hopper periodically or when you find conveying capacity reduced. Please loose the spring clips, take down the hopper lid, and take out filter screen. Remove all the dusts and fines on filter screen and inside of material hopper.

## 6.2 Main Body

Take out the air filter to make it clean periodically or when you find conveying capacity reduced. Always keep smooth air flow through air filter to maintain good conveying capacity.

Cleaning steps:

- 1) Loosen spring clips of filter cover and butterfly screws, and take out the filter.
- 2) Remove the dusts adhering to the filter to keep good suction power.

## 6.3 Glass Tube

When you find that there are material grains clinging to the inner surface of glass tube, please make it clean timely to keep proper function of the machine.

- 1) Loosen the stainless steel pipe clamp and take down the installation flange.
- 2) Blow the glass pipe with the air gun according to the direction of arrow to blow away materials on the glass pipe or clean it with cloth.

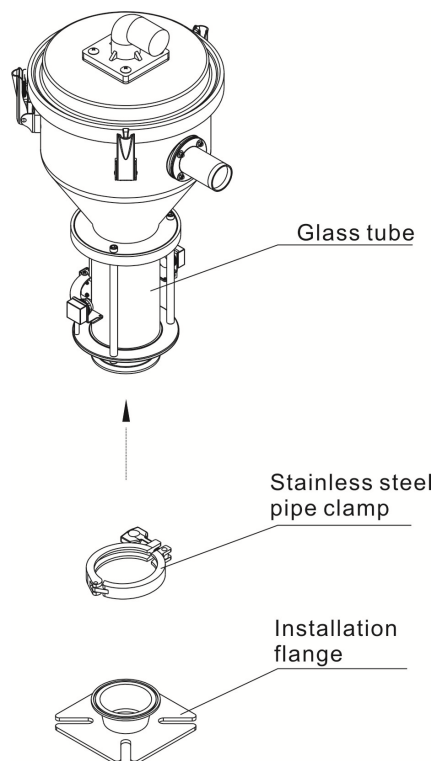

**Note: Be careful not to break glass tube during cleaning.**

## 6.4 Reed Switch, Photoelectric Switch

### Reed switch

When the indicator of the reed switch doesn't work, check the switch contact and replace with a new one if it doesn't work well.

- 1) Unscrew the outer box of the sensor.
- 2) Adjust the depth or move position the sensor inserted into the box, the indicator lamp lights means that magnetism has been detected and the switch is well worked.
- 3) If magnetism cannot be detected by magnets, please check whether the switch is bad contacted or damaged.

### Photoelectric Switch

When the indicator of the photoelectric switch doesn't work, check the switch contact and replace with a new one if it doesn't work well.

- 1) Check whether the wires are bad contacted.
- 2) Please replace with a new one if the switch is damaged.

## 6.5 Weekly Checking

- 1) Check if there are broken electrical wires or not. Replace the broken wires immediately.
- 2) Check the function of the keys on the control panel.
- 3) Check if screws at material inlet and the seal ring are loose or not.

***Note: Cut off power supply when you check electrical wires.***

## 6.6 Monthly Checking

- 1) Check if the clips of hopper lids are loose or not.
- 2) Check if the reverse stopping flap is out of shape. If it is, please replace it.
- 3) Check the performance of magnetic proximity switch or photo sensor. If there is poor contact, please fix the problem or replace it.

## 6.7 Maintenance Schedule

### 6.7.1 About the Machine

Model \_\_\_\_\_ SN \_\_\_\_\_ Manufacture date \_\_\_\_\_

Voltage \_\_\_\_\_  $\Phi$  \_\_\_\_\_ V Frequency \_\_\_\_\_ Hz Power \_\_\_\_\_ kW

### 6.7.2 Installation & Inspection

- Check if the takeover pipe has been correctly connected.
- Check if that pipe is locked up by clips.
- Check if mounting base is locked tightly.

#### Electrical Installation

- Voltage: \_\_\_\_\_ V \_\_\_\_\_ Hz
- Fuse melting current: One-phase: A \_\_\_\_\_ Three-phase: \_\_\_\_\_ A
- Check phase sequence of power supply.

### 6.7.3 Daily Checking

- Check main power switch.
- Check filter mesh.
- Check working status of the motor.

### 6.7.4 Weekly Checking

- Check all the electrical cables.
- Check if there are loose connections of electrical components.
- Check the screw of the feed-in pipe's flange is loosed or not.
- Check the air filter.

### 6.7.5 Monthly Checking

- Check the spring lock on the hopper cover is loosed or not.
- Check the reversal stop piece is deformed or not.
- Check the performance of magnetic proximity switch/photoelectrical sensor.