



## Three/Five Axes Servo Driven Robot (Driven-control integrated)

ST5-800-1400DT-S2-I



Refer carefully to this manual before operation.

# ST3/5 Series

## ■ Coding Principle

ST3/5 - xxx - xxx DT - S - I

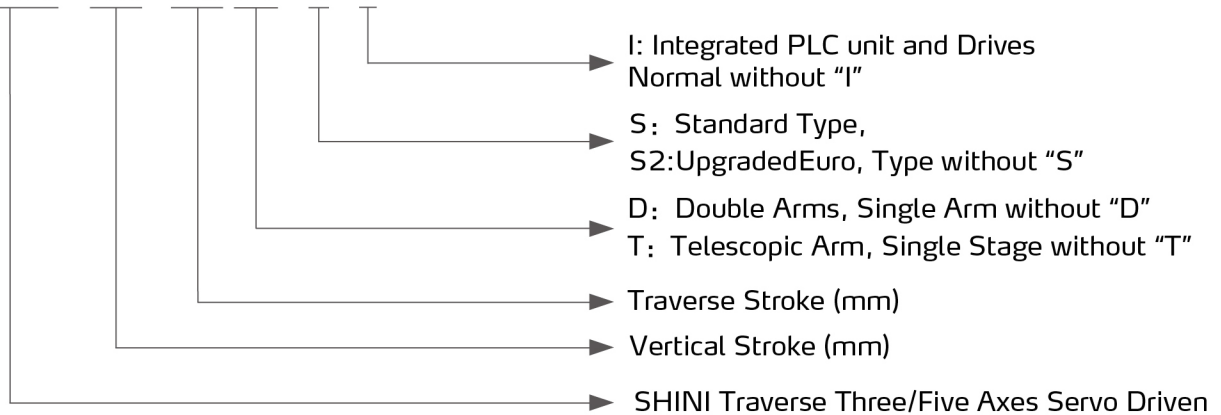

## ■ Features

- Advanced driver ensures stable performance;
- Highly modular design and card split structure makes it only has to change corresponding module without disassembling and replacing the whole machine during maintenance, which is better than most of other drive-control units in the market.
- The shared DC bus makes the driver work more stably, with better overload capacity. Moreover, it only needs a regenerative resistor, which saves mount space.
- The main control module and the servo module are connected in the unified base plate, which avoid cumbersome manual wiring and increases the system's stability and reliability;
- The servo parameters can be set by the control plate automatically;
- The bus controlled interface is suitable for all kinds of IMM's (national, European and Japanese standards), suitable for new 7" manipulator;
- It not only features the split stability, but also saves the labor works of wiring, and it shortens the size of the control box.

## ■ Application

Thina series robot is designed for rapid and precise removal of products from injection molding machine, and place them at desired locations. Apply to 2/3-plate mold or hot runner system. Capable of arranging, stacking, quality checking and in mold placement. Suitable for injection molding machine with clamping force 80~300 tons.

## Outline Drawings

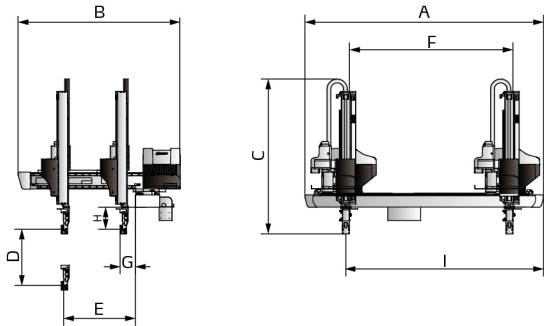

3-axis servo with single kick-stroke beam

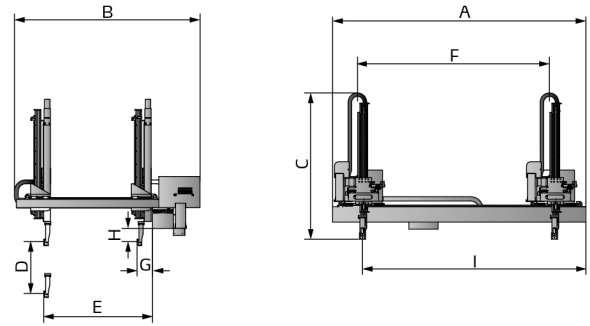

3-axis telescopic arm with frame type beam

## Specifications

| Model                            | ST3-     | 800-1400T-S2-I          | 1000-1600T-S2-I         | 1200-1800T-S2-I                               | 1300-2000T-S2-I                               |
|----------------------------------|----------|-------------------------|-------------------------|---|---|
| Robot Type                       |          | Single kick stroke beam | Single kick stroke beam | Frame type beam<br>(Drive-control Integrated) | Frame type beam<br>(Drive-control Integrated) |
| IMM (ton)                        |          | 80-160                  | 180-300                 | 320-450                                       | 480-650                                       |
| Traverse Stroke (mm)             |          | 1400                    | 1600                    | 1800  | 2000  |
| Crosswise Stroke (mm)            | Main Arm | 800                     | 900                     | 1100  | 1100  |
|                                  | Sub. Arm | -                       | -                       | -   | -   |
| Vertical Stroke (mm)             | Main Arm | 800                     | 1000                    | 1200  | 1300  |
|                                  | Sub. Arm | -                       | -                       | -   | -   |
| Max Load (with tool) (kg)        |          | 5                       | 5                       | 6   | 6   |
| Min Pick-out Time (sec)          |          | 1.3                     | 1.4                     | 1.5   | 1.8   |
| Min Cycle Time (sec)             |          | 5.2                     | 5.5                     | 6.5   | 6.8   |
| Air Pressure (bar)               |          | 4~6                     | 4~6                     | 4~6   | 4~6   |
| Max. Air Consumption (NL/cycle)* |          | 4                       | 4                       | 4   | 6   |
| Weight (kg)                      |          | 250                     | 300                     | 320   | 340   |
| Dimensions (mm)                  | A        | 2100                    | 2310                    | 2550  | 2750  |
|                                  | B        | 1600                    | 1800                    | 1950  | 1900  |
|                                  | C        | 1300                    | 1400                    | 1450  | 1500  |
|                                  | D        | 800                     | 1000                    | 1200  | 1300  |
|                                  | E        | 800                     | 900                     | 1160  | 1160  |
|                                  | F        | 1400                    | 1600                    | 1800  | 2000  |
|                                  | G        | 180                     | 180                     | 250   | 250   |
|                                  | H        | 230                     | 230                     | 200   | 200   |
|                                  | I        | 1650                    | 1900                    | 2200  | 2400  |

Notes: 1) "M" stands for middle mold detector. (suitable for three-plate mold.)

"EM12" stands for EUROMAP 12 communication interface.

"EM67" stands for EUROMAP 12 communication interface.

"N" stands for non-operation side, operation side without "N"

2) Power supply: 1Φ, 200~240V, 50/60Hz.

3) \* \* \* Max. air consumption for vacuum device 60NL/min.

# ST3/5 Series

## Outline Drawings

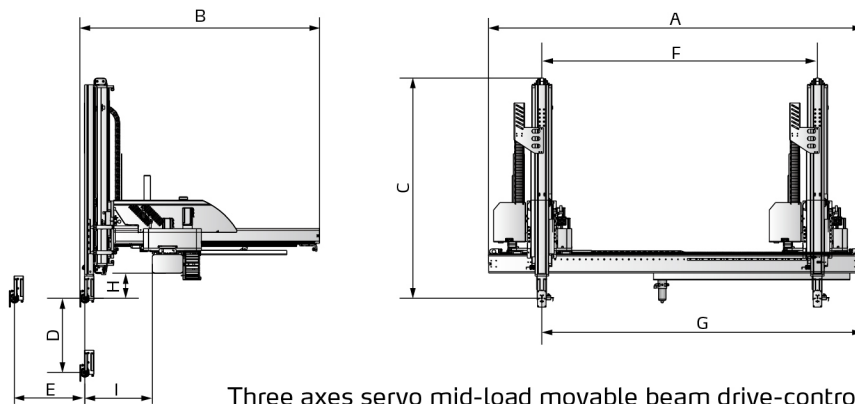

Three axes servo mid-load movable beam drive-control integrated robot

## Specifications

| Model                            | ST3-   | 1400-2000MT-S-I | 1600-2200MT-S-I | 1800-2400MT-S-I |
|----------------------------------|--|-----------------|-----------------|-----------------|
| Robot Type                       | Movable beam type (Drive-control Integrated) |                 |                 |                 |
| IMM (ton)                        |  | 480-650         | 650-850         | 850-1400        |
| Traverse Stroke (mm)             |  | 2000            | 2200            | 2400            |
| Crosswise Stroke (mm)            | Main Arm                                     | 1000            | 1600            | 1600            |
|                                  | Sub. Arm                                     | -               | -               | -               |
| Vertical Stroke (mm)             | Main Arm                                     | 1400            | 1600            | 1800            |
|                                  | Sub. Arm                                     | -               | -               | -               |
| Max Load (with tool) (kg)        |  | 10              | 20              | 20              |
| Min Pick-out Time (sec)          |  | 3               | 3.3             | 3.6             |
| Min Cycle Time (sec)             |  | 13              | 14              | 16              |
| Air Pressure (bar)               |  | 4~6             | 4~6             | 4~6             |
| Max. Air Consumption (NI/cycle)* |  | 6               | 6               | 6               |
| Weight (kg)                      |  | 530             | 580             | 650             |
| Dimensions (mm)                  | A  | 2700            | 2900            | 3100            |
|                                  | B  | 1817            | 2500            | 2500            |
|                                  | C  | 1680            | 1890            | 1990            |
|                                  | D  | 1400            | 1600            | 1800            |
|                                  | E  | 1000            | 1600            | 1600            |
|                                  | F  | 2000            | 2200            | 2400            |
|                                  | G  | 2450            | 2650            | 2850            |
|                                  | H  | 145             | 220             | 220             |
|                                  | I  | 355             | 355             | 355             |

Notes: 1) "M" stands for middle mold detector. (suitable for three-plate mold.)

"EM12" stands for EUROMAP 12 communication interface.

"EM67" stands for EUROMAP 12 communication interface.

"N" stands for non-operation side, operation side without "N"

2) Power supply: 1Φ, 200-240V, 50/60Hz.

3) " \* " Max. air consumption for vacuum device 60NI/min.

## Outline Drawings

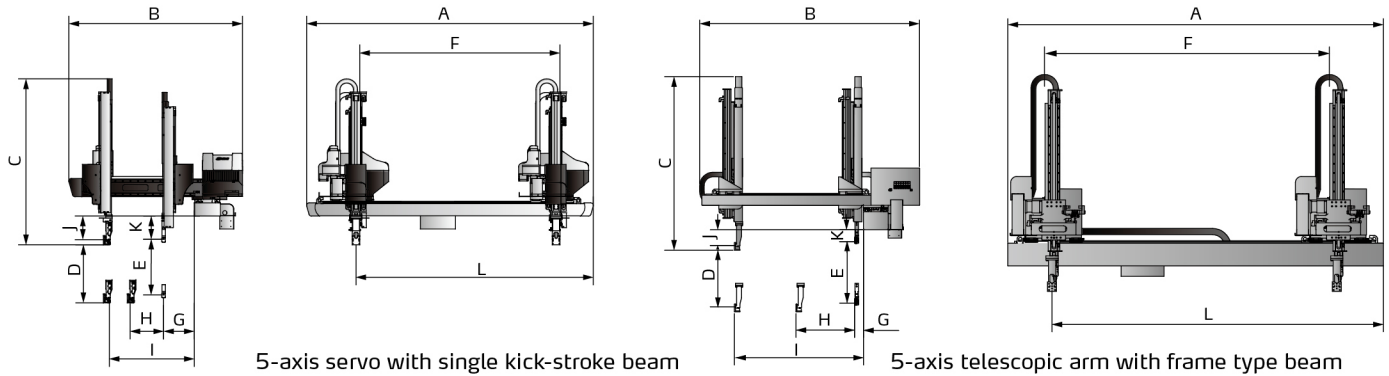

## Specifications

| Model                             | ST5-                                      | 800-1400DT-S2-I | 1000-1600DT-S2-I | 1200-1800DT-S2-I                           | 1300-2000DT-S-I | 1500-2200DT-S-I |
|-----------------------------------|---|-----------------|------------------|--|-----------------|-----------------|
| Robot Type                        | 5-axis servo with single kick-stroke beam |                 |                  | 5-axis telescopic arm with frame type beam |                 |                 |
| IMM (ton)                         |   | 80-160          | 180-300          | 320-450                                    | 480-650         | 660-850         |
| IMM (ton)                         |   | 1400            | 1600             | 1800                                       | 2000            | 2200            |
| Crosswise Stroke (mm)             | Main Arm                                  | 500             | 700              | 850  | 850             | 1050            |
|                                   | Sub. Arm                                  | 500             | 700              | 850  | 850             | 1050            |
| Vertical Stroke (mm)              | Main Arm                                  | 800             | 1000             | 1200                                       | 1300            | 1500            |
|                                   | Sub. Arm                                  | 800             | 1000             | 1200                                       | 1300            | 1500            |
| Max Load (with tool) (kg)         |   | 5               | 5                | 6  | 6               | 12              |
| Min Pick-out Time (sec)           |   | 1.3             | 1.4              | 1.5  | 1.8             | 2.0             |
| Min Cycle Time (sec)              |   | 5.2             | 5.5              | 6.3  | 6.8             | 12              |
| Air Pressure (bar)                |   | 4-6             | 4-6              | 4-6  | 4-6             | 4-6             |
| Max. Air Consumption (NI/cycle) * |   | 4               | 4                | 4  | 6               | 6               |
| Weight (kg)                       |   | 290             | 320              | 340  | 360             | 450             |
| Dimensions (mm)                   | A   | 2060            | 2310             | 2550                                       | 2750            | 3100            |
|                                   | B   | 1600            | 1700             | 1900                                       | 1900            | 2160            |
|                                   | C   | 1250            | 1350             | 1450                                       | 1500            | 1740            |
|                                   | D   | 800             | 1000             | 1200                                       | 1300            | 1500            |
|                                   | E   | 800             | 1000             | 1200                                       | 1300            | 1500            |
|                                   | F   | 1400            | 1600             | 1800                                       | 2000            | 2200            |
|                                   | G   | 180             | 180              | 250  | 250             | 230             |
|                                   | H   | 110             | 110              | 220  | 220             | 440             |
|                                   | I   | 800             | 900              | 1160                                       | 1160            | 1540            |
|                                   | J   | 230             | 230              | 200  | 200             | 245             |
|                                   | K   | 220             | 220              | 200  | 200             | 245             |
|                                   | L   | 1650            | 1900             | 2200                                       | 2400            | 2620            |

Notes: 1) "M" stands for middle mold detector. (suitable for three-plate mold.)

"EM12" stands for EUROMAP 12 communication interface.

"EM67" stands for EUROMAP 12 communication interface.

"N" stands for non-operation side, operation side without "N"

2) Power supply: 1Φ, 200-240V, 50/60Hz.

3) " \* " Max. air consumption for vacuum device 60NI/min.

## Shini Group

Addr: No. 23, Minhe St., Shulin Dist.,  
New Taipei, Taiwan

Tel: +886 2 2680 9119

Fax: +886 2 2680 9229

Email: [shini@shini.com](mailto:shini@shini.com)

### Factories:

- Taiwan
- Dongguan
- Pinghu
- Ningbo
- Chongqing
- Pune

2024-06-15-04 Copyrights Reserved.

[www.shini.com](http://www.shini.com)